

# CHROME PLASTIC “MOON” AXLE COVER KIT WITH REMOVABLE HUB CAP

33 mm THREAD-ON  
FOR CLASS 8 SERIES TRUCKS

## MOUNTING INSTRUCTION

- FITS 10-HOLE, 22 1/2" OR 24 1/2", HUB OR STUD PILOTED WHEELS
- AVAILABLE WITH 33 mm OR 1 1/2" NUT COVERS
- NUT COVERS AVAILABLE WITH THREAD-ON OR PUSH-ON DESIGN
- REAR AXLE COVER WITH “MOON” REMOVABLE CAP FOR EASY ACCESS
- FITS ALL 11 1/4" BOLT CIRCLE WHEELS
- MADE FROM PLASTIC THAT IS HIGH-IMPACT, LIGHT-WEIGHT, AND FLEXIBLE
- HIGH-SHINE CHROME FINISH RESISTS DENTS AND NICKS AND NEVER RUSTS

“MOON” REAR AXLE COVER KIT CONTAINS THE FOLLOWING:

REAR AXLE COVER WITH “MOON” REMOVABLE CAP, 10 NUT COVERS, PLASTIC RIM PROTECTOR, AND 2 METAL WASHERS (INCLUDED WITH PUSH-ON NUT COVERS ONLY). FOR INSTALLATION ON AN ALUMINUM WHEEL, INSERT THE ENCLOSED PLASTIC RIM PROTECTOR BETWEEN THE ALUMINUM RIM AND THE REAR AXLE COVER

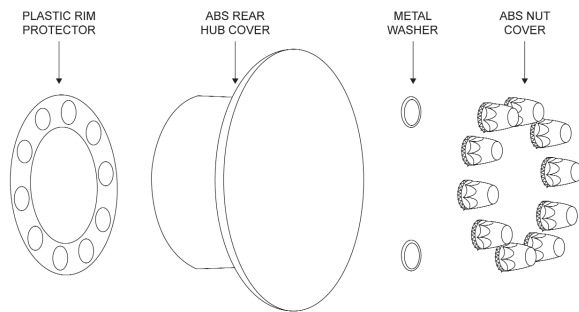

**33MM THREAD-ON INSTRUCTION** ( A MINIMUM OF 3 THREADS EXTENDING THROUGH THE TOP OF EACH NUT IS REQUIRED FOR INSTALLATIONS):

1. Remove kit from packaging.
2. For installation on an aluminum wheel, insert the enclosed plastic rim protector between the aluminum rim and the Rear Axle Cover.
3. Align all 10 holes of the cover over the studs and nuts.
4. Install 33 mm threaded nut covers on each stud by turning clockwise until locked. A clicking sound should occur. Nut covers should now be secure on each nut.

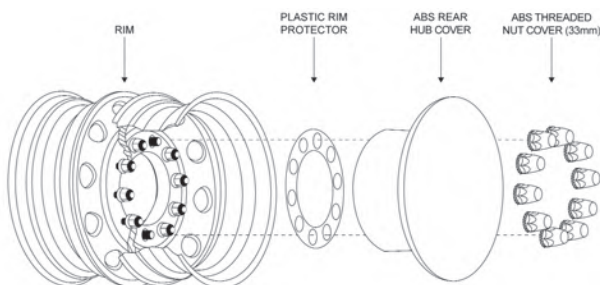

**33 mm OR 1 1/2" PUSH-ON INSTRUCTION** ( FOR USE WITH SHORTER STUDS WHEN NO THREADS ARE AVAILABLE):

1. Remove kit from packaging.
2. For installation on an aluminum wheel, insert the enclosed plastic rim protector between the aluminum rim and the Rear Axle Cover.
3. Remove two opposite 33 mm or 1 1/2" wheel nuts from the wheel and align all 10 holes of the cover over the studs and nuts.
4. Install one metal washer over each stud with the removed 33 mm or 1 1/2" wheel nut by inserting the tab into the inner guide hole so that the washer lays flat side up. (The raised surface of the washer should face the inside rim of the hole.)
5. Re-install the 33 mm or 1 1/2" wheel nuts (over the metal washers.) Please note: wheel nuts should face the inside rim of the hole.)
6. Install 33 mm or 1 1/2" nut covers on each nut by pushing until the nut cover is flush with the inside rim of the hole. Nut covers should now be secure on each nut.

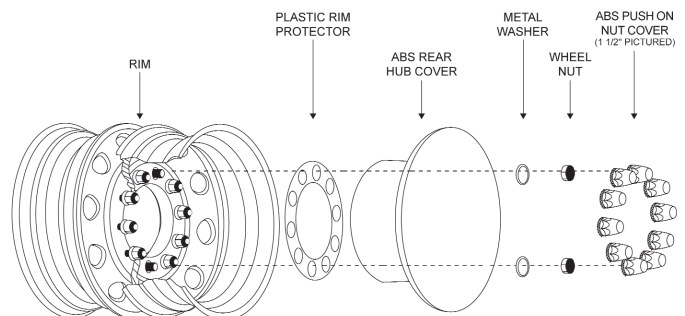

### CAUTION:

THE PLASTIC RIM PROTECTOR MUST BE USED WHEN THIS PRODUCT IS PLACED ON ANY ALUMINUM RIM TO PREVENT COSMETIC DAMAGE ON THE SOFT ALUMINUM RIM. UNITED PACIFIC SHALL NOT BE RESPONSIBLE FOR IMPROPER INSTALLATION OF THE PRODUCT.