

REVISION HISTORY		
REV.	DESCRIPTION	DATE
05	REVISED PER EP0135	2022-05-25
06	REVISED PER EP0135	2022-06-02
A	INITIAL RELEASE PER EP0135	2022-06-13

## SPECIFICATIONS

- CERTIFICATIONS: **CE**; ECE R10; AMECA/SAE J845 (FEB 2019) CLASS 1A; YELLOW, WHITE; CA Title 13 CLASS E, AMBER; ; Reg 65 CertE6 TA1 000428; IP69K  
Note: Unique components, accessories, and hardware kits are not typically included in the Product Certification Test Protocols. Unless otherwise Specified, the Product Certifications referred to herein are predicated upon the base product model configuration.
- FLASH MODE: SINGLE : 75 ± 5 FLASHES PER MINUTE  
SINGLE : 120 ± 5 FLASHES PER MINUTE  
DOUBLE : 75 ± 5 FLASHES PER MINUTE
- VOLTAGE (NOMINAL): 12-24 VDC
- VOLTAGE (EXTREME): 9.0-32 VDC
- CURRENT (PEAK): 6.52A (@ 12 VDC NOMINAL)
- POWER (MAXIMUM): 83.5W (@ 12 VDC NOMINAL)
- TEMPERATURE RANGE: -40°F (-40°C) TO 185°F (85°C)
- CONNECTION: 15' CORD W/DUAL SWITCH LIGHTER ADAPTER
- MOUNTING: MAGNET MOUNT
- BASE MATERIAL: ALUMINUM
- LENS MATERIAL: POLYCARBONATE
- PRODUCT WEIGHT: 4.4 LBS (1.98 Kg)

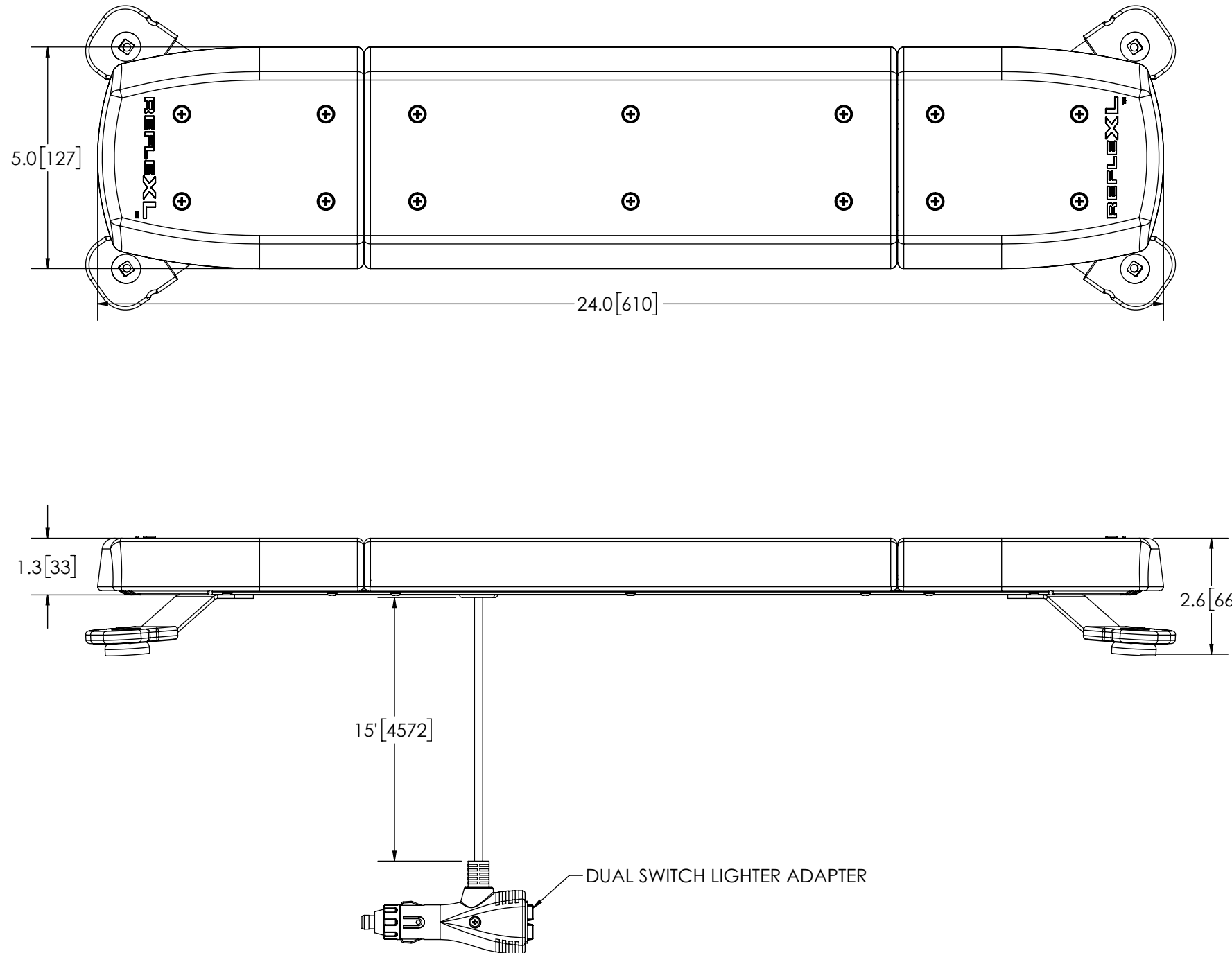

COLOR CHART	
FGS. NO.	COLOR
11-024CAC-E-MG	AMBER/WHITE

### NOTES:

- ROHS COMPLIANT
- DIMENSIONS IN INCHES[MILLIMETERS (FOR REFERENCE)]

PROPRIETARY AND CONFIDENTIAL INFORMATION

THIS DRAWING AND THE DESIGN AND OTHER INFORMATION DISCLOSED HEREIN ARE THE PROPERTY OF ELECTRONIC CONTROLS COMPANY AND/OR ITS ECCO SAFETY GROUP AFFILIATES ("ECCO") AND IS ISSUED IN CONFIDENCE TO RECIPIENT FOR ENGINEERING INFORMATION PURPOSES ONLY. THIS DRAWING AND THE DESIGN AND OTHER INFORMATION DISCLOSED HEREIN MAY NOT BE USED, COPIED, REPRODUCED OR OTHERWISE DISCLOSED IN PART OR IN WHOLE TO THIRD PARTIES OR USED FOR ANY OTHER PURPOSE WITHOUT PRIOR ECCO WRITTEN CONSENT. ECCO RESERVES ALL PATENT, COPYRIGHT, TRADEMARK AND OTHER PROPRIETARY RIGHTS TO THIS DOCUMENT, INCLUDING ALL DESIGN, MANUFACTURING, REPRODUCTION, USE AND SALES RIGHTS THEREOF. THIS DRAWING IS SUBJECT TO RECALL BY ECCO AT ANY TIME, AND YOUR POSSESSION AND/OR USE CONSTITUTES ACCEPTANCE OF THESE TERMS. ©2022 ELECTRONIC CONTROLS COMPANY

SCALE 1:3	APPROVALS	DATE	<b>ECCO</b> ® www.eccolink.com Americas (800) 635-5900   Europe +44 (0)113 237 5340   Asia Pacific +61 (0)3 63322444							
CAD GENERATED DRAWING DO NOT MANUALLY UPDATE.	DRAWN BY BTK CHECKED ABD	2022-06-02 2022-06-02								
TOLERANCES ARE IN INCHES, AND MILLIMETERS TOLERANCES UNLESS OTHERWISE STATED ARE:	MECH. ENG. NMT	2022-06-03	<b>REFLEX XL, 24", CLR LENS, MAG MOUNT</b> CUSTOMER PART NO. <b>SEE CHART</b>							
<table border="1"> <tr> <th>MILLIMETERS DECIMALS</th> <th>INCHES DECIMALS</th> <th>ANGLES</th> <th>FRACTIONS</th> </tr> <tr> <td>XX ± 1.0mm XX.X ± 0.5mm</td> <td>X.X ± 0.1 X.XX ± 0.04 X.XXX ± 0.02</td> <td>± 0.5°</td> <td>± 1/64</td> </tr> </table>	MILLIMETERS DECIMALS	INCHES DECIMALS		ANGLES	FRACTIONS	XX ± 1.0mm XX.X ± 0.5mm	X.X ± 0.1 X.XX ± 0.04 X.XXX ± 0.02	± 0.5°	± 1/64	ELEC. ENG. SPO TEST ENG. BMH SALES.
MILLIMETERS DECIMALS	INCHES DECIMALS	ANGLES	FRACTIONS							
XX ± 1.0mm XX.X ± 0.5mm	X.X ± 0.1 X.XX ± 0.04 X.XXX ± 0.02	± 0.5°	± 1/64							
THIRD ANGLE PROJECTION 			<table border="1"> <tr> <td>SIZE: B</td> <td>DWG. NO. 11-024CXX-E-MG</td> <td>REV. A</td> </tr> </table>	SIZE: B	DWG. NO. 11-024CXX-E-MG	REV. A				
SIZE: B	DWG. NO. 11-024CXX-E-MG	REV. A								
Electronically Controlled Use Latest Copy			<table border="1"> <tr> <td>SHEET 1 OF 1</td> <td>Project: EP0135</td> <td>Date Created: 2022-02-21</td> </tr> </table>	SHEET 1 OF 1	Project: EP0135	Date Created: 2022-02-21				
SHEET 1 OF 1	Project: EP0135	Date Created: 2022-02-21								