



Installation and Operation Instructions 12+ Pro Vantage™ Series Lightbars

IMPORTANT! Read all instructions before installing and using. Installer: This manual must be delivered to the end user. This manual assumes installation by a suitably qualified Automotive Technician.



Do not install and/or operate this safety product unless you have read and understand the safety information contained in this manual.

1. Proper installation combined with operator training in the use, care and maintenance of emergency warning devices are essential to ensure the safety of emergency personnel and the public.
2. Emergency warning devices often require high electrical voltages and/or currents. Exercise caution when working with live electrical connections.
3. This product must be properly grounded. Inadequate grounding and/or shorting of electrical connections can cause high current arcing, which can cause personal injury and/or severe vehicle damage, including fire.
4. Proper placement and installation is vital to the performance of this warning device. Install this product so that output performance of the system is maximized and the controls are placed within convenient reach of the operator so that s/he can operate the system without losing eye contact with the roadway.
5. It is the responsibility of the vehicle operator to ensure daily that all features of this product work correctly. In use, the vehicle operator should ensure the projection of the warning signal is not blocked by vehicle components (i.e., open trunks or compartment doors), people, vehicles or other obstructions.
6. The use of this or any other warning device does not ensure all drivers can or will observe or react to an emergency warning signal. Never take the right-of-way for granted. It is your responsibility to be sure you can proceed safely before entering an intersection, drive against traffic, respond at a high rate of speed, or walk on or around traffic lanes.
7. This equipment is intended for use by authorized personnel only. The user is responsible for understanding and obeying all laws regarding emergency warning devices. Therefore, the user should check all applicable city, state, and federal laws and regulations. The manufacturer assumes no liability for any loss resulting from the use of this warning device.
8. This product may contain high intensity LEDs staring directly into these lights could result in temporary and/or permanent vision impairment.



WARNING!

Failure to install or use this product according to manufacturer's recommendations may result in property damage, serious bodily/personal injury, and/or death to you and those you are seeking to protect!

Unpacking and Pre-Installation:

Carefully remove the lightbar and place it on a flat surface. Examine the unit for transit damage and locate all parts. If damage is found or parts are missing, contact the transit company or ECCO. Do not use damaged or broken parts. Ensure the lightbar voltage is compatible with the planned installation.

Specifications:

Length.....24", 30", 36", 42", 48", 54", 60", 72"
 Width.....11"
 Height.....2.5"
 Voltage.....12-24VDC
 Current Draw.....Single Color LED Module = 0.55A Avg. @ 12.8VDC
 Dual Color LED Module = 0.55A Avg. @ 12.8VDC
 LED STT (pair) = 1.2A Avg. @ 12.8VDC
 LED AL,TD,WL = 1.2A Avg. @ 12.8VDC
 Flash Patterns.....70

Fuse Recommendation:

Calculate the total amp draw from all the LED Modules. Multiply the total amp draw by 1.25. Round up to the nearest fuse.

Installation & Mounting:

Mounting

Before proceeding with installation, plan all wiring and cable routing. Select the mounting location for the lightbar on a flat, smooth surface and center the unit across the width of the vehicle. The mounting location for the lightbar should be chosen such that the lightbar is level and visibility to approaching traffic is optimized. Mounting should be such that there is no less than 1/2" clearance between the roof and the lightbar at any point.



Caution:

When drilling into any vehicle surface, make sure that the area is free from any electrical wires, fuel lines, vehicle upholstery, vehicle support members, etc. that could be damaged.

Permanent Mounting

1. Determine the location of the lightbar, and the best route for the wiring. Install on the structural part of the roof or surface that has the least amount of flex.
2. Determine the position of the mounting feet and drill the 5/16"-11/32" diameter mounting holes accordingly, if needed. The spacing of the mounting feet from left to right is adjustable. It is suggested that the positioning of the feet be symmetrical and near the curved edges of the roof where the roof is strongest. Ideally, the outermost holes on the feet should be used for installation.
3. Mount the lightbar, with the bolts going through the holes drilled in step 2, routing the wire as planned in step 1 (refer to diagram). See the Wiring section of this manual for further wiring instructions. Install washers and nuts and secure the unit.

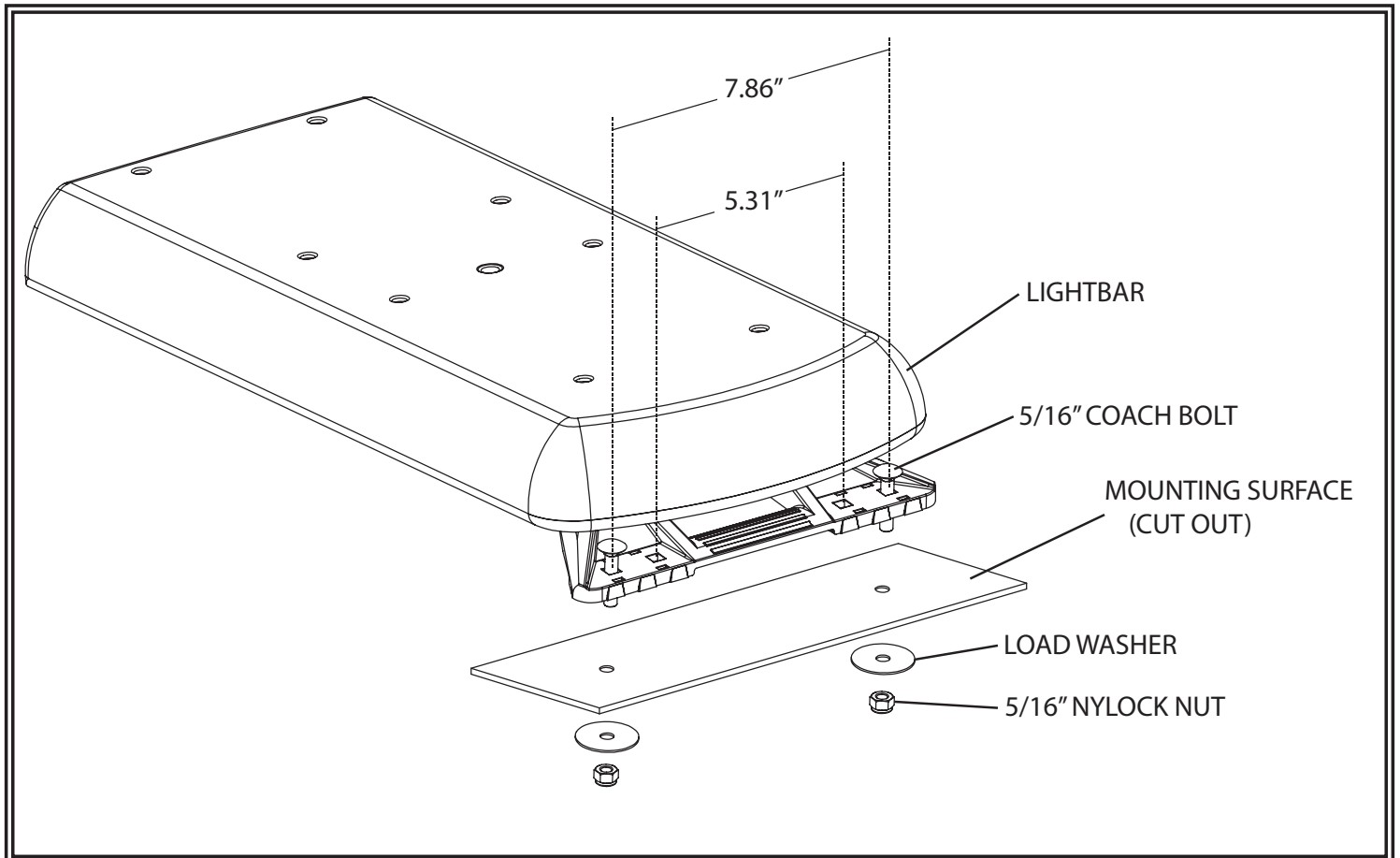

Gutter Mounting

Important!

Mounting brackets are specific to the vehicle model. Please make sure the brackets are suitable for the vehicle before installation. Install on the structural part of the roof that has the least amount of flex.

1. Remove mounting foot. Position bracket onto nubs of the foot.
2. Holding the bracket and foot together, insert the cage nut as shown. It will fit snugly underneath the mounting foot. Do not install it on the outside face.
3. Install the mounting feet in reverse order of their removal. The metal bracket will be sandwiched between the bar and the composite mounting foot. Adjust the spacing of the mounting feet before securely tightening the nuts.
4. Hand thread the M6 bolt through the star washer and mounting strap into the cage nut. Be careful not to cross thread the bolt, and leave loose until later steps.
5. Once the bar is in position, use the strap as a template to drill $\text{\O}1/8$ " holes. It may be necessary to pull back the door sealing gasket or trim. Apply silicone or sealant around the hole, behind the strap. Secure the straps with the provided #10 stainless steel sheet metal screws with washers as shown. Screws should be tightened around 5-10 in-lb.
6. Tighten the M6 bolts evenly so that the bar is even and centered. Reinstall any removed trim and/or weather-stripping and close doors to check secure fit of the lightbar.

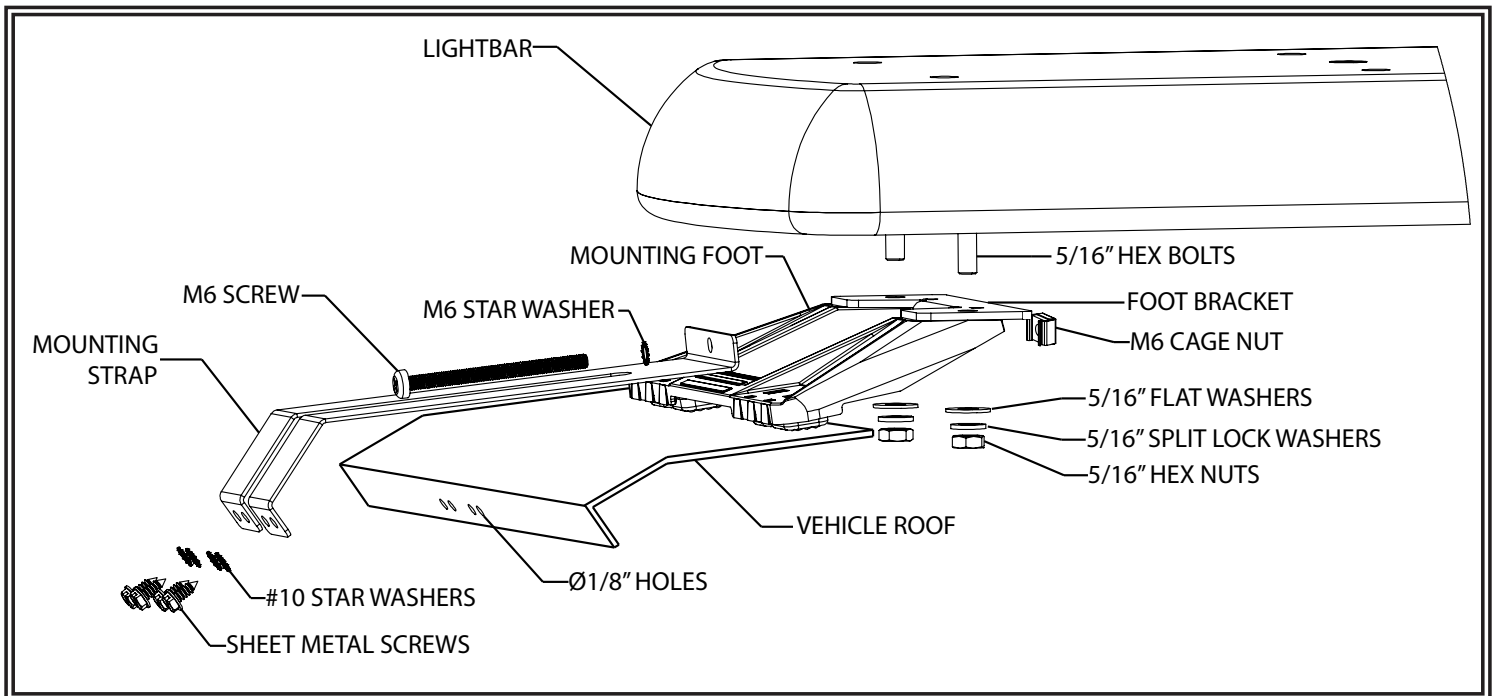

Wiring Instructions:

Important!

This unit is a safety device and it must be connected to its own separate, fused power point to assure its continued operation should any other electrical accessory fail. Do not wire in parallel with any other accessory.

Notes:

1. Larger wires and tight connections will provide longer service life for components. For high current wires it is highly recommended that terminal blocks or soldered connections be used with shrink tubing to protect the connections. Do not use insulation displacement connectors (e.g., 3M Scotchlock type connectors).
2. Route wiring using grommets and sealant when passing through compartment walls. Minimize the number of splices to reduce voltage drop. High ambient temperatures (e.g., under-hood) will significantly reduce the current carrying capacity of wires, fuses, and circuit breakers. All wiring should conform to the minimum wire size and other recommendations of the manufacturer and be protected from moving parts and hot surfaces. Looms, grommets, cable ties, and similar installation hardware should be used to anchor and protect all wiring.
3. Fuses or circuit breakers should be located as close to the power takeoff points as possible and properly sized to protect the wiring and devices.
4. Particular attention should be paid to the location and method of making electrical connections and splices to protect these points from corrosion and loss of conductivity.
5. Ground termination should only be made to substantial chassis components, preferably directly to the vehicle battery.
6. Circuit breakers are very sensitive to high temperatures and will "false trip" when mounted in hot environments or operated close to their capacity.



CAUTION!

Disconnect the battery before wiring up the lightbar, to prevent accidental shorting, arcing and/or electrical shock.

General Wiring Instructions

Before attempting to connect the lightbar wiring harness, refer to the wiring diagram illustrated below. The wiring diagram describes the function for each separate wire.

1. Route the lightbar power cable's red wire to a fused, ignition-switched power point. Connect the black wire to a solid ground connection on the vehicle (ideally, directly to the battery negative terminal). Use a fuse according to the wiring diagram.
2. After the lightbar has been mounted, route the control cable into the vehicle to the switch panel/controller location.
3. Connect the wires of the lightbar wiring harness to the switched side of each switch, or plug into optional controller. See the wiring diagram for wire color/function legend.
4. Use cable ties and grommets to secure and protect all cables and wires.

STANDARD WIRING (Discrete cables for power/ground and control)

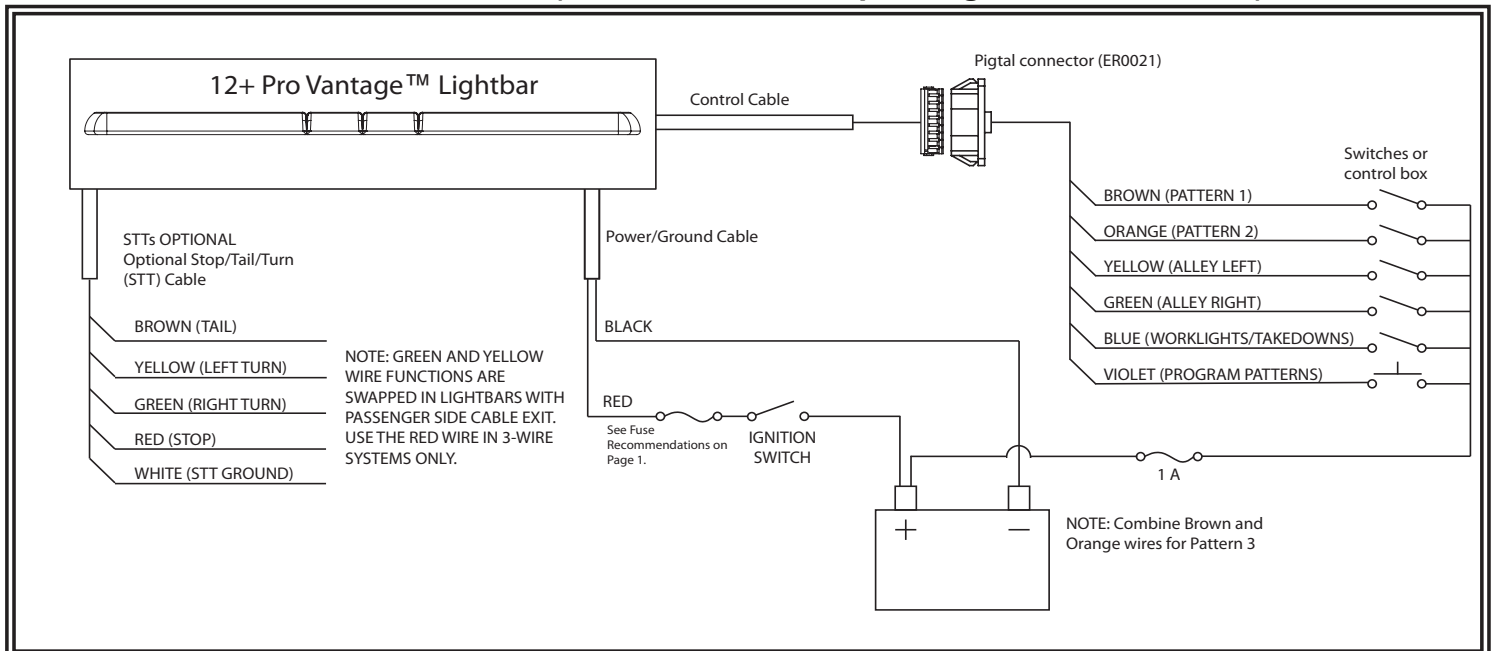

Programming Standard and Combined Power/Signal Cables:

To change the flash pattern, apply power to the desired Pattern Wire. Next, double-tap the violet wire to power to enter pattern selection mode. Single-tap the violet wire to power to cycle through flash patterns. Isolate the violet wire once pattern selections are complete.

COMBINED POWER/SIGNAL CABLE

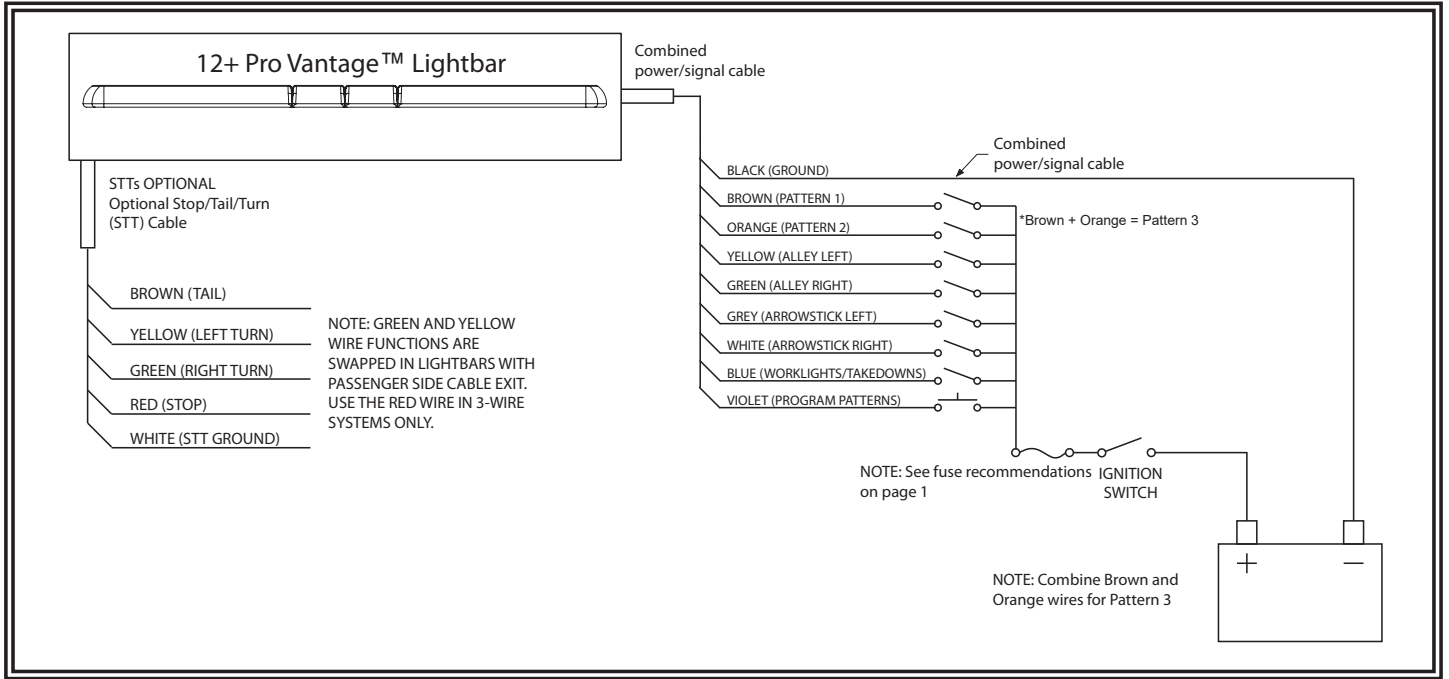

ADVANCED CONTROLLER (EZ1202)

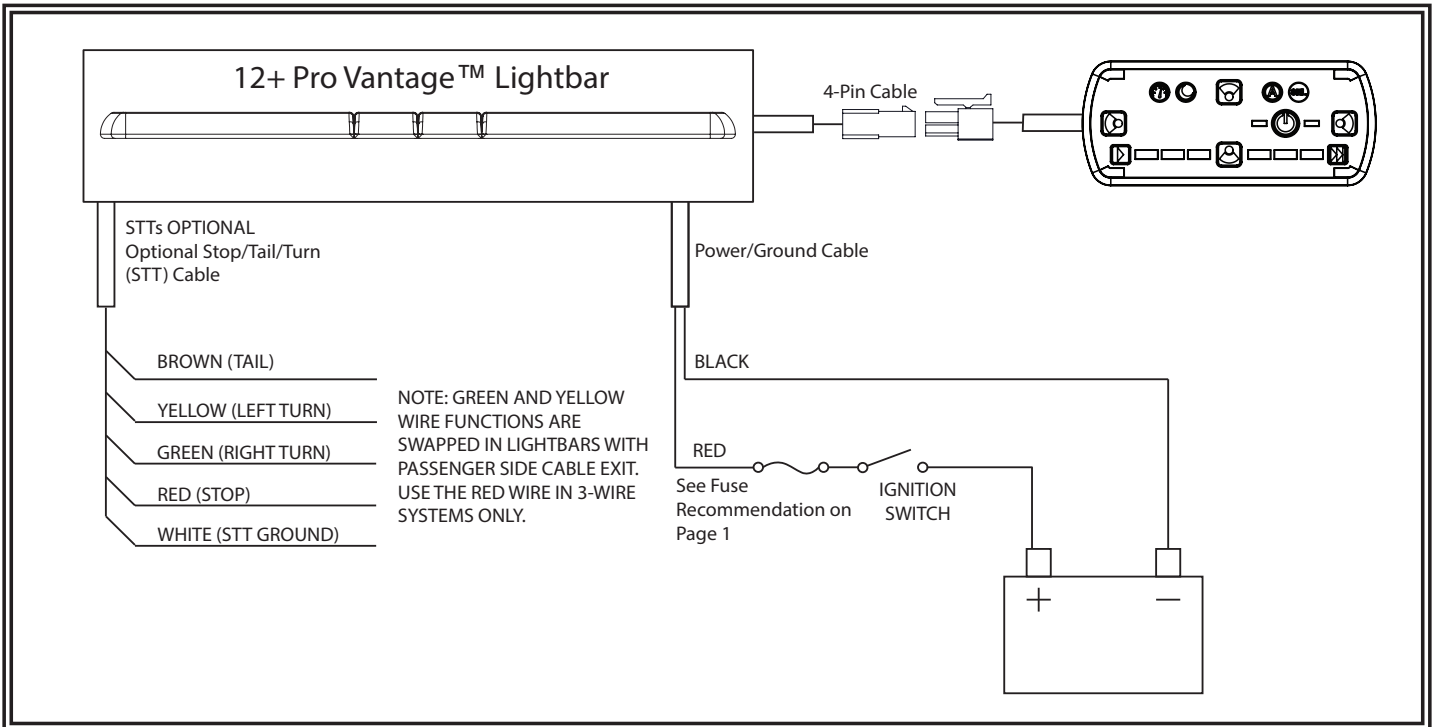

SERIAL INTERFACE BOX (EZMATSIB)

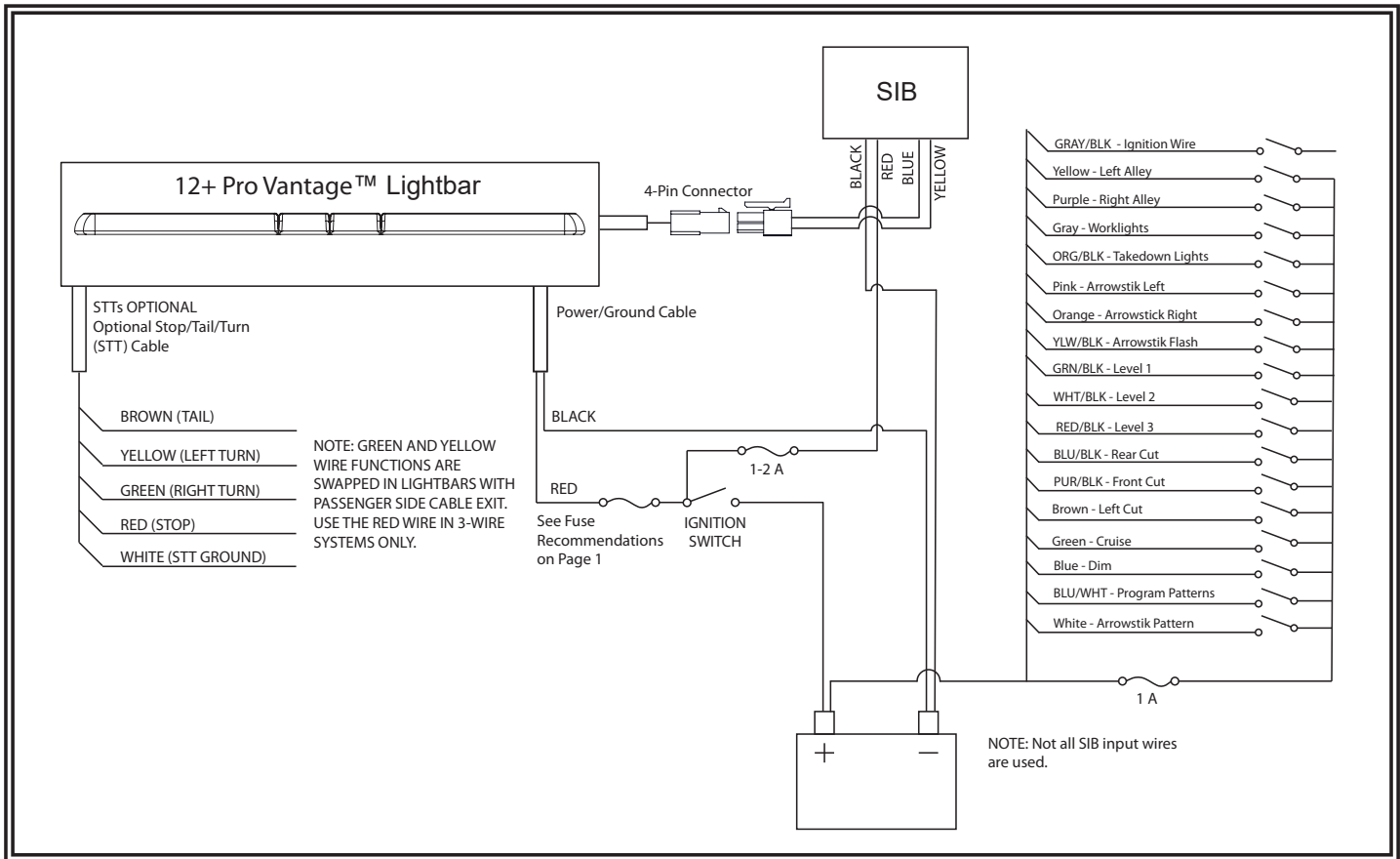

Maintenance:

Occasional cleaning of the lenses will ensure optimum light output. Take care when cleaning lenses – although tough, polycarbonate scratches easily. Clean the lens and base with soap and water or a lens polish using a soft cloth. Do not use solvents as they may damage the polycarbonate. Do not subject the lightbar to high-pressure washers or automatic car washers.

Lens Removal and Installation

1. Remove the screws from the lenses. Starting at one edge, pull the lens off.
2. Carefully lift the lens off the seal – choose a suitable location to temporarily store the lens so as to not scratch the surface.
3. When reinstalling, gently apply pressure around the lens taking care not to damage the seal. Replace the screws.

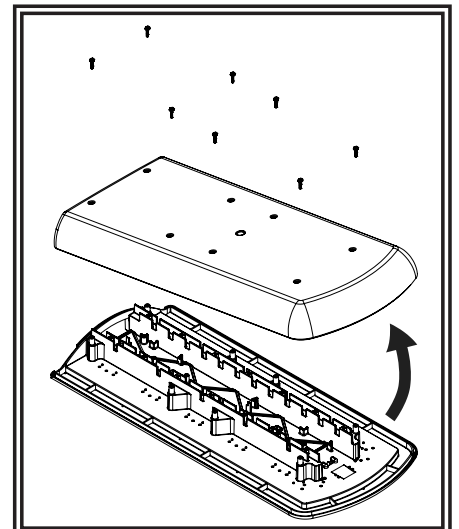

Warning LED Modules (EZ1203X, EZ1206XX)

The LED lighthoods have been designed to ensure long service life using high performance LEDs. The modules are low profile units that have a high intensity output with low current draw. The LED lighthoods can be mounted in the front, rear and corners of the lightbar.

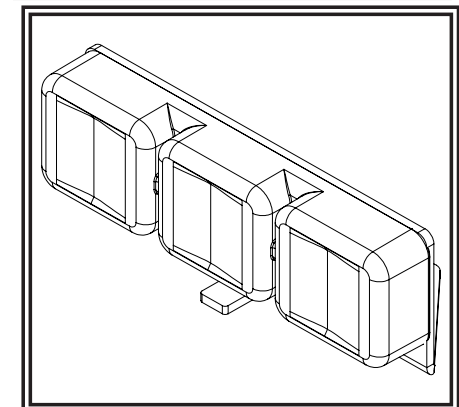

Alley / Takedown / Worklight LED Modules (EZ0003)

Alley / Takedown / Worklight LED Module can be mounted anywhere in the lightbar.

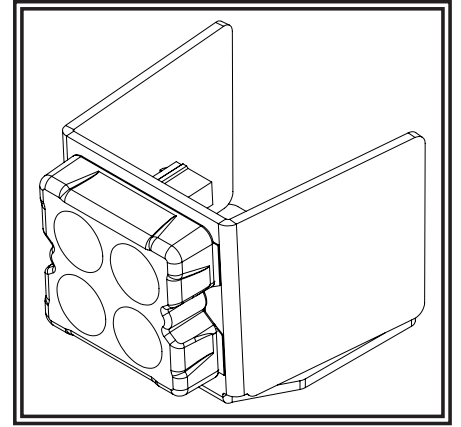

Stop / Tail / Turn LED Modules (EZ1205)

Stop Tail Turn modules operate in conjunction with the vehicle tail, brake and direction indicator lights. Kit includes a pair of modules, installation hardware and wiring.

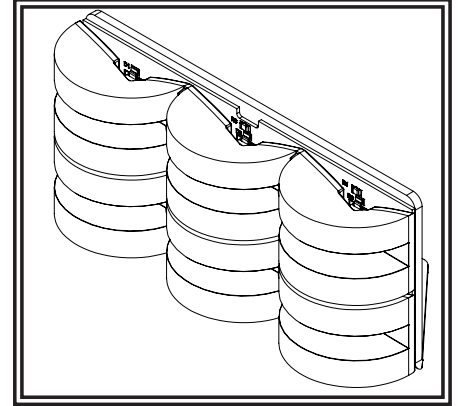

Advanced Controller (EZ1202)

Provides convenient control of the lightbar's built-in flash patterns and features soft touch buttons and LED function indicator lights.

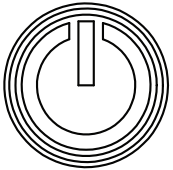
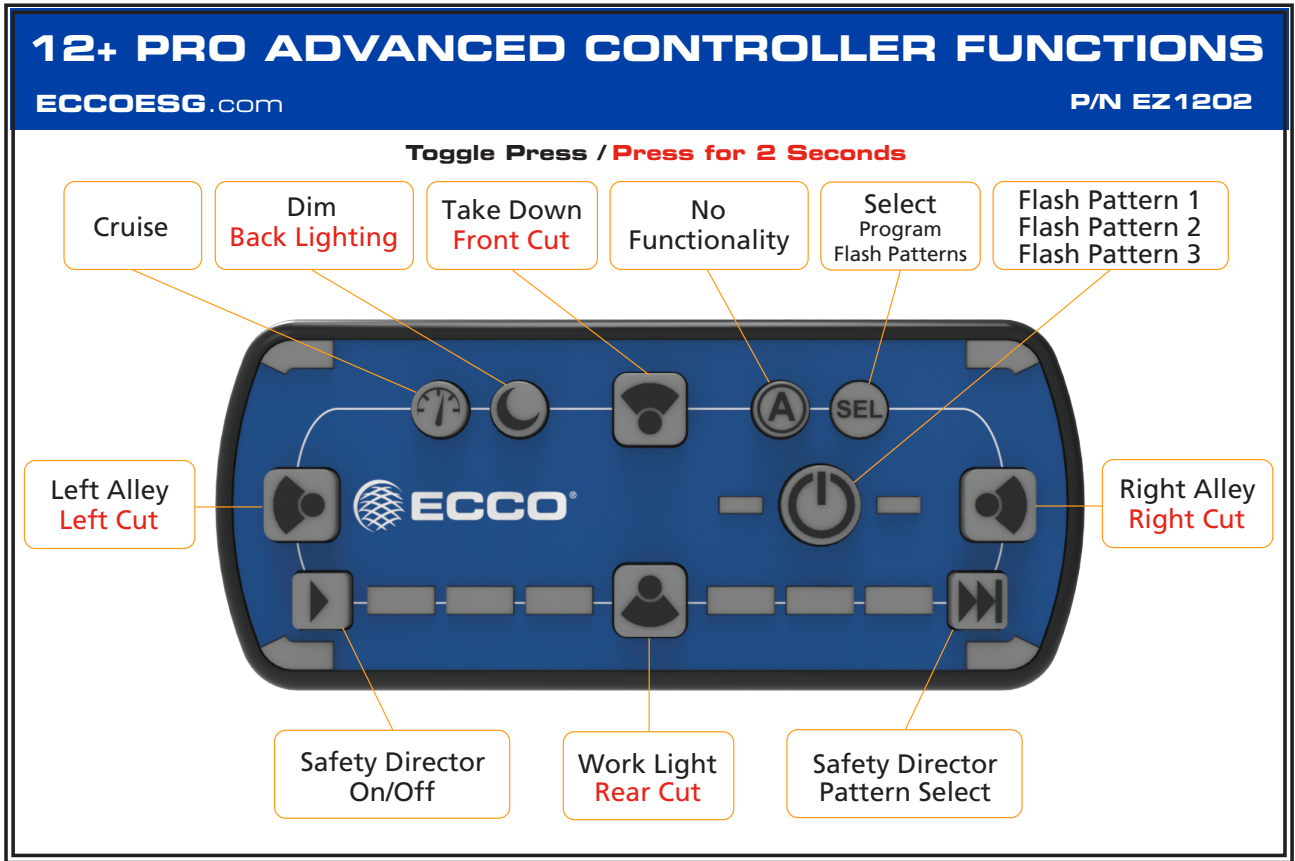

“Power” - Press to cycle through three programmable flash pattern presets. Hold button down to shut down all functions. Press again to resume.

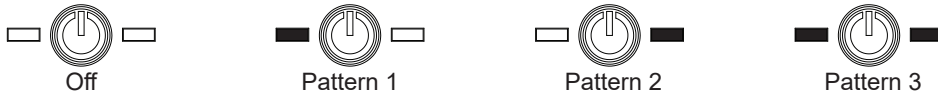

“Cruise” - Press to illuminate all directional modules in steady burn mode.

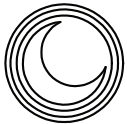

“Dim Mode” - Toggle press to dim standard flash patterns. Note, this mode will not dim takedown, alley and worklights. Long-press this button for two seconds to activate or deactivate backlighting on the control head.



No Functionality



“Flash Pattern Select” - First, select Pattern 1, 2 or 3 to program by pushing the Power Button. Next, double press to enter flash pattern select mode and cycle one flash pattern. The 4 corner LEDs on the controller will mimic the lightbar to give pattern feedback. Press again once to cycle to the next flash pattern. Press and hold for 3 seconds to return to the prior flash pattern. The lightbar will store the last flash pattern used to the active preset. After 30 seconds of inactivity in Select mode, the control head will automatically exit Select mode.

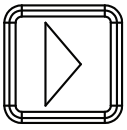

“Safety Director On/Off” - Press once to turn the Safety Director on or off.

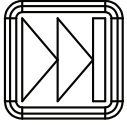

“Safety Director Pattern Select” - Once the Safety Director is activated, press this pattern select button to cycle to the next Safety Director flash pattern. There is a 5 second delay between the controller and the lightbar. Press and hold for 3 seconds to return to the prior flash pattern. The lightbar will store the last flash pattern used.

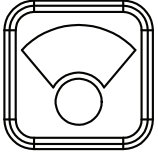

“Front Worklight (Takedown)” - Toggle press will activate/deactivate front worklight function. Long press for two seconds to activate/deactivate front cut.

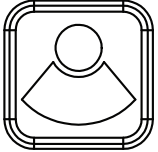

“Back Worklight” - Toggle press will activate/deactivate rear worklight function. Long press for two seconds to activate/deactivate back cut.

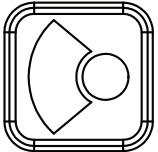

“Left Worklight (Alley)” - Toggle press will activate/deactivate rear left worklight function. Long press for two seconds to activate/deactivate left cut.

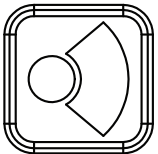

“Right Worklight (Alley)” - Toggle press will activate/deactivate right worklight function. Long press for two seconds to activate/deactivate right cut.

Special Features:

Touchpad Backlight





Reset the Lightbar back to Factory Setting: Press SEL button 8 times. The lightbar will flash 3 times and will reset back to factory settings.

To limit the lightbar to R65 flash patterns, press SEL 5 times and bar will flash twice.

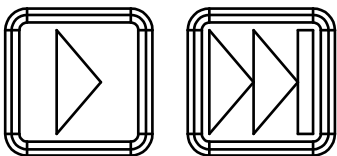
Safety Director Module Selection



To change the number of modules used in the safety director, press and hold  - tap  to select 5 to 10 modules.

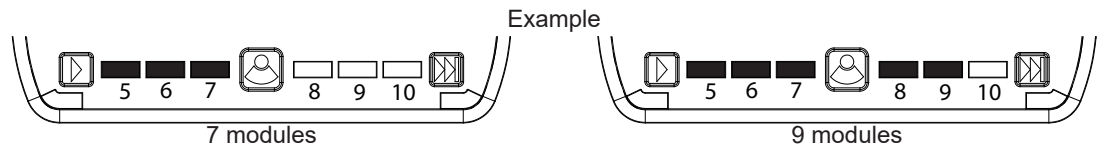

Safety Director Front/Rear Selection

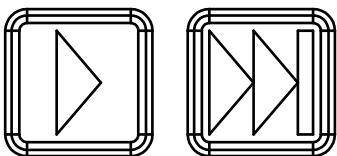

Press  to turn on the safety director.

Press and hold  , once the corner LEDs light, tap  to cycle front, rear or both.

Advanced Control Pad Mounting:

The advanced control pad is supplied with three mounting options: a bracket, VHB tape and hook and loop patch. The rear of the control pad is designed to allow for the cable exit to be routed five different ways to maximize installation locations. Mount the control pad in a location within convenient reach of the operator so that s/he can operate the system without losing eye contact with the roadway.

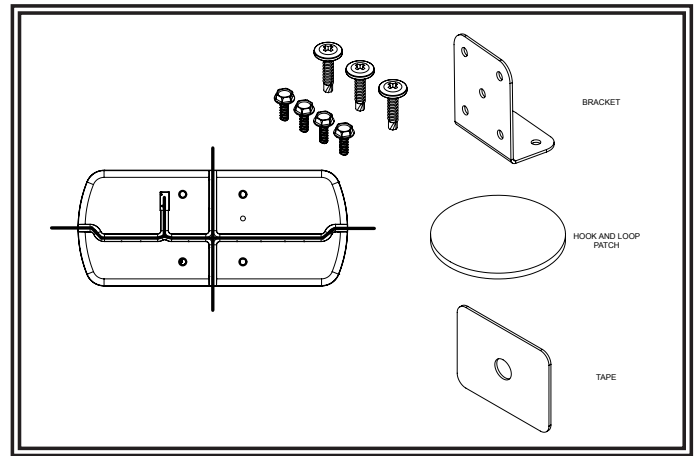

Advanced Controller Mount (EZ1415):

This holder can easily be mounted in the cab of a vehicle using the attached suction cup. Control head is placed inside the grips. The angle of the holder can be changed using the adjustable knobs.

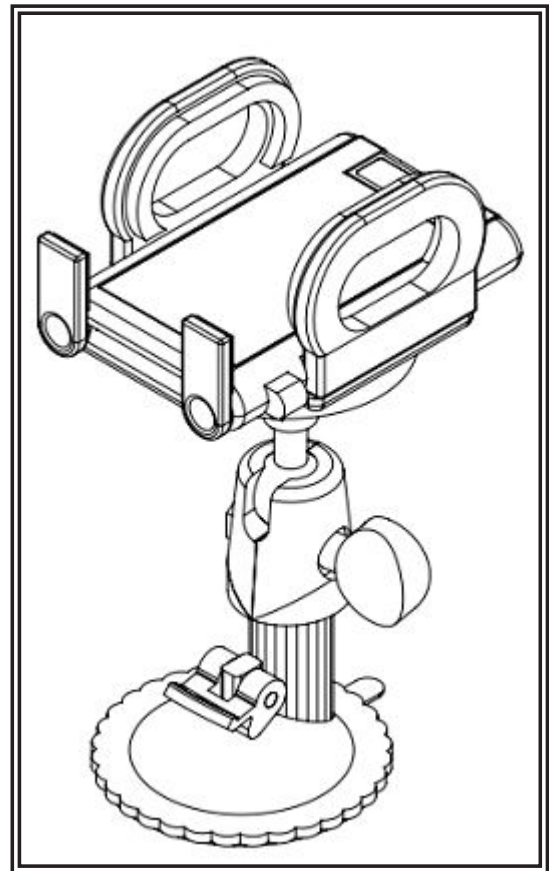

Replacement Parts/Accessories:

Description	Part No.
Lenses	
Replacement 24" End Lens - Clear	ER0003
Replacement 6" Mid Lens - Clear	ER0004
Driver PCA	
12 Channel Driver Board	Call ECCO Rep
20 Channel Driver Board	Call ECCO Rep
Led Modules	
3-LED Ice Optic Module - Amber	EZ1203A
3-LED Ice Optic Module - Blue	EZ1203B
3-LED Ice Optic Module - Green	EZ1203G
3-LED Ice Optic Module - Red	EZ1203R
3- LED Ice Optic Module - White	EZ1203W
4-LED Worklight / Alley Light Module Pair - White	EZ0003
6-LED Flare Optic Stop / Turn / Tail (STT) Module Pair - Red	EZ1205
6-LED Ice Optic Dual Color Module - Amber / Blue	EZ1206AB
6-LED Ice Optic Dual Color Module - Amber / Red	EZ1206AR
6-LED Ice Optic Dual Color Module - Amber / White	EZ1206AW
6-LED Ice Optic Dual Color Module - Blue / White	EZ1206BW
6-LED Ice Optic Dual Color Module - Red / Blue	EZ1206RB
6-LED Ice Optic Dual Color Module - Red / White	EZ1206RW
Cables	
15' Extension Cable - For use with Standard Wiring	EZ0008
23' Extension Cable - For use with Standard Wiring	EZ0008-23
48' Extension Cable - For use with Standard Wiring	EZ0008-48
15' Extension Cable - For use with Advanced Controller EZ1202	EZ1210
48' Extension Cable - For use with Advanced Controller EZ1202	EZ1413-48
15' Power Cable	ER0020
6" Discrete Wiring Harness (Pigtail) - For use with Standard Wiring	ER0021
Control Options	
Advanced Controller	EZ1202
Serial Interface Box (SIB)	EZMATSIB
Remote Rocker Max Pak, 6 button controller	450R-L6
6-Rocker Switch Panel	A9000
Single Illuminated Rocker Switch	A9891
Single Switch Panel - For use with A9891 Switch	A9893
Single Illuminate Rocker Switch	A9901
End Switch Panel Section - For use with A9901 Switch	A9902
Center Switch Panel Section - For use with A9901 Switch & End Panel Sections A9902	A9903
Switch Panel Mounting Kit - For use with A9901 Switch & Panel Sections A9902 & A9903	A9904
On / Off Switch Panel with Pattern Select	A9905SW
Mounting Kits	
Permanent mounting feet and hardware - Black	ER0002
Permanent mounting feet and hardware - White	ER0001
Headache rack mounting kit	A1032RMK

NOTE: For list of vehicle specific brackets, please contact an ECCO representative or our latest catalog.

Troubleshooting:

All lightbars are thoroughly tested prior to shipment. However, should you encounter a problem during installation or during the life of the product, follow the guide below for troubleshooting and repair information. If the problem cannot be rectified using the solutions given below, additional information may be obtained from the manufacturer – contact details are at the end of this document.

LIGHTBAR AND CONTROLLER

PROBLEM	POSSIBLE CAUSE	SOLUTION
Does not function	Poor power or ground connection	If controller functions normally, or if a 12/24V control voltage is present on either the Pattern 1 (brown) or Pattern 2 (orange) wires, then replace the driver board in the lightbar. If controller does not function, then check fuse, cables, and connections to the lightbar and to the controller.
	Blown fuse	Check wiring, replace fuse
One or two LED head do not flash, but Pattern 1 or Pattern 2 indicator LED on control module is on.	Open circuit wiring from control module to LED head	Connect a known-good LED head to the problem output to ensure the control module is working correctly. Repair or replace.
	Failed LED head	Replace LED head
LED head flashes dimly	Defective head or driver board	Check correct LED head
Incorrect flash patterns	Wrong flash configuration	Re-program the lightbar flash pattern for either Program 1 or Program 2, or both.
Secondary pattern does not function	Normal operation	Primary function overrides secondary function – turn off primary function

ALLEY / TAKEDOWN / WORKLIGHTS

PROBLEM	POSSIBLE CAUSE	SOLUTION
Light does not function	Defective light	Replace light
	Defective controller	If indicator LED on controller is lit, then it is either the light, or the cable to the light, or the driver board. Otherwise the controller is defective.

STOP/TAIL/TURN

PROBLEM	POSSIBLE CAUSE	SOLUTION
Both/all lights do not function	Blown fuse	Check wiring, replace fuse
	No power	Check to see if vehicle S/T/T lights function properly
	Failed S/T/T LED head	Make sure that the S/T/T head is plugged into the S/T/T control board and not the driver board. Replace S/T/T LED head and/or its cable.

 **NOTE: Operating the vehicle without the outer lens installed on the product may result in damage that will NOT be covered under the warranty.**

Electronics Controls Company "ECCO" (Manufacturer)

ECCO warrants that on the date of purchase, this product will conform to ECCO's specifications for this product (which are available from ECCO upon request). This Limited Warranty extends for sixty (60) months from the date of purchase.

DAMAGE TO PARTS OR PRODUCTS RESULTING FROM TAMPERING, ACCIDENT, ABUSE, MISUSE, NEGLIGENCE, UN-APPROVED MODIFICATIONS, FIRE OR OTHER HAZARD; IMPROPER INSTALLATION OR OPERATION; OR NOT BEING MAINTAINED IN ACCORDANCE WITH THE MAINTENANCE PROCEDURES SET FORTH IN ECCO'S INSTALLATION AND OPERATING INSTRUCTIONS VOIDS THIS LIMITED WARRANTY.

Exclusion of Other Warranties:

ECCO MAKES NO OTHER WARRANTIES, EXPRESSED OR IMPLIED. THE IMPLIED WARRANTIES FOR MERCHANTABILITY, QUALITY OR FITNESS FOR A PARTICULAR PURPOSE, OR ARISING FROM A COURSE OF DEALING, USAGE OR TRADE PRACTICE ARE HEREBY EXCLUDED AND SHALL NOT APPLY TO THE PRODUCT AND ARE HEREBY DISCLAIMED, EXCEPT TO THE EXTENT PROHIBITED BY APPLICABLE LAW. ORAL STATEMENTS OR REPRESENTATIONS ABOUT THE PRODUCT DO NOT CONSTITUTE WARRANTIES.

Remedies and Limitation of Liability:

ECCO'S SOLE LIABILITY AND BUYER'S EXCLUSIVE REMEDY IN CONTRACT, TORT (INCLUDING NEGLIGENCE), OR UNDER ANY OTHER THEORY AGAINST ECCO REGARDING THE PRODUCT AND ITS USE SHALL BE, AT ECCO'S DISCRETION, THE REPLACEMENT OR REPAIR OF THE PRODUCT, OR THE REFUND OF THE PURCHASE PRICE PAID BY BUYER FOR NON-CONFORMING PRODUCT. IN NO EVENT SHALL ECCO'S LIABILITY ARISING OUT OF THIS LIMITED WARRANTY OR ANY OTHER CLAIM RELATED TO THE ECCO'S PRODUCTS EXCEED THE AMOUNT PAID FOR THE PRODUCT BY BUYER AT THE TIME OF THE ORIGINAL PURCHASE. IN NO EVENT SHALL ECCO BE LIABLE FOR LOST PROFITS, THE COST OF SUBSTITUTE EQUIPMENT OR LABOR, PROPERTY DAMAGE, OR OTHER SPECIAL, CONSEQUENTIAL, OR INCIDENTAL DAMAGES BASED UPON ANY CLAIM FOR BREACH OF CONTRACT, IMPROPER INSTALLATION, NEGLIGENCE, OR OTHER CLAIM, EVEN IF ECCO OR A REPRESENTATIVE OF ECCO HAS BEEN ADVISED OF THE POSSIBILITY OF SUCH DAMAGES. ECCO SHALL HAVE NO FURTHER OBLIGATION OR LIABILITY WITH RESPECT TO THE PRODUCT OR ITS SALE, OPERATION AND USE, AND ECCO NEITHER ASSUMES NOR AUTHORIZES THE ASSUMPTION OF ANY OTHER OBLIGATION OR LIABILITY IN CONNECTION WITH SUCH PRODUCT.

This Limited Warranty defines specific legal rights. You may have other legal rights which vary from jurisdiction to jurisdiction. Some jurisdictions do not allow the exclusion or limitation of incidental or consequential damages.



833 West Diamond St, Boise, Idaho 83705
Customer Service USA 800-635-5900
UK +44 (0)113 237 5340 | AUS +61 (0)3 63322444
ECCOESG.com

An ECCO SAFETY GROUP™ Brand
ECCOSAFETYGROUP.com