

# AUXILIARY STROBE & STOP LAMP

DATA SHEET

WARNING AND HAZARD LIGHTING

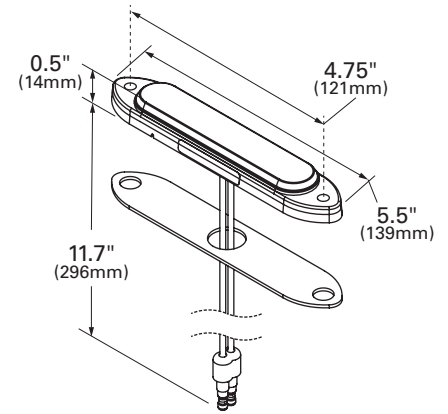

Give following motorists greater warning of braking and increase your visibility with our new strobing warning light. Take safety to the next level with Grote's new Auxiliary Strobe & Stop Lamp.

- 5-year warranty
- Several wiring options to fit all harness systems
- 5 amber flashes in 4 seconds, followed by a solid red burn
- Studies show that flashing brake lights can reduce rear-end accidents by more than a third.

## PRODUCT SPECIFICATIONS

### MATERIALS:

Housing Material: Black Powder Coated Cast Aluminum  
Lens Material: UV Stable Clear Polycarbonate

### ELECTRONIC CHARACTERISTICS:

Connector Type: Grote Standard .180 Male Bullets  
Input Voltage: 12V

### RATINGS AND COMPLIANCES:

SAE J595 Class II For Amber Warning  
SAE J186a Sep 1977 for Supplemental High Mounted Stop & Rear Turn Signal  
SAE J1889 Jul 2019 for LED Signal and Marking Light

### MOUNTING

2 Hole Surface Mount  
(2) 0.2" Mounting Holes

PART NUMBER	DESCRIPTION	VOLTAGE	AMPERAGE
78462	AUXILIARY STROBE & STOP LAMP	12V	0.2A-0.4A
78462-3	AUXILIARY STROBE & STOP LAMP BULK PACK	12V	0.2A-0.4A

FOR MORE  
INFORMATION  
VISIT **GROTE.COM**

Grote Industries, Inc. 2600 Lanier Drive, Madison, Indiana U.S.A. 47250-0550  
U.S. 800.628.0809 | Europe +49 9422 40331-0 | China +86.21.5774.9633  
Canada 800.268.5612 | Mexico +(52) 818262 4412

