

WHELEN[®]

ENGINEERING COMPANY INC.

51 Winthrop Road
Chester, Connecticut 06412-0684
Phone: (860) 526-9504
Internet: www.whelen.com
Sales e-mail: autosale@whelen.com
Customer Service e-mail: custserv@whelen.com

Installation Guide:
Cenator™ Lightbar
(HC)

Warnings to Installers

Whelen's emergency vehicle warning devices must be properly mounted and wired in order to be effective and safe. Read and follow all of Whelen's written instructions when installing or using this device. Emergency vehicles are often operated under high speed stressful conditions which must be accounted for when installing all emergency warning devices. Controls should be placed within convenient reach of the operator so that they can operate the system without taking their eyes off the roadway. Emergency warning devices can require high electrical voltages and/or currents. Properly protect and use caution around live electrical connections. Grounding or shorting of electrical connections can cause high current arcing, which can cause personal injury and/or vehicle damage, including fire. Many electronic devices used in emergency vehicles can create or be affected by electromagnetic interference. Therefore, after installation of any electronic device it is necessary to test all electronic equipment simultaneously to insure that they operate free of interference from other components within the vehicle. Never power emergency warning equipment from the same circuit or share the same grounding circuit with radio communication equipment. All devices should be mounted in accordance with the manufacturer's instructions and securely fastened to vehicle elements of sufficient strength to withstand the forces applied to the device. Driver and/or passenger air bags (SRS) will affect the way equipment should be mounted. This device should be mounted by permanent installation and within the zones specified by the vehicle manufacturer, if any. Any device mounted in the deployment area of an air bag will damage or reduce the effectiveness of the air bag and may damage or dislodge the device. Installer must be sure that this device, its mounting hardware and electrical supply wiring does not interfere with the air bag or the SRS wiring or sensors. Mounting the unit inside the vehicle by a method other than permanent installation is not recommended as unit may become dislodged during swerving; sudden braking or collision. Failure to follow instructions can result in personal injury. Whelen assumes no liability for any loss resulting from the use of this warning device. **PROPER INSTALLATION COMBINED WITH OPERATOR TRAINING IN THE PROPER USE OF EMERGENCY WARNING DEVICES IS ESSENTIAL TO INSURE THE SAFETY OF EMERGENCY PERSONNEL AND THE PUBLIC.**

Warnings to Users

Whelen's emergency vehicle warning devices are intended to alert other operators and pedestrians to the presence and operation of emergency vehicles and personnel. However, the use of this or any other Whelen emergency warning device does not guarantee that you will have the right-of-way or that other drivers and pedestrians will properly heed an emergency warning signal. Never assume you have the right-of-way. It is your responsibility to proceed safely before entering an intersection, driving against traffic, responding at a high rate of speed, or walking on or around traffic lanes. Emergency vehicle warning devices should be tested on a daily basis to ensure that they operate properly. When in actual use, the operator must ensure that both visual and audible warnings are not blocked by vehicle components (i.e.: open trunks or compartment doors), people, vehicles, or other obstructions. It is the user's responsibility to understand and obey all laws regarding emergency warning devices. The user should be familiar with all applicable laws and regulations prior to the use of any emergency vehicle warning device. Whelen's audible warning devices are designed to project sound in a forward direction away from the vehicle occupants. However, because sustained periodic exposure to loud sounds can cause hearing loss, all audible warning devices should be installed and operated in accordance with the standards established by the National Fire Protection Association.

Safety First

This document provides all the necessary information to allow your Whelen product to be properly and safely installed. Before beginning the installation and/or operation of your new product, the installation technician and operator must read this manual completely. Important information is contained herein that could prevent serious injury or damage.

⚠ WARNING: This product can expose you to chemicals including Methylene Chloride which is known to the State of California to cause cancer, and Bisphenol A, which is known to the State of California to cause birth defects or other reproductive harm. For more information go to www.P65Warnings.ca.gov.

- **Proper installation of this product requires the installer to have a good understanding of automotive electronics, systems and procedures.**
- **Whelen Engineering requires the use of waterproof butt splices and/or connectors if that connector could be exposed to moisture.**
- **Any holes, either created or utilized by this product, should be made both air- and watertight using a sealant recommended by your vehicle manufacturer.**
- **Failure to use specified installation parts and/or hardware will void the product warranty.**
- **If mounting this product requires drilling holes, the installer MUST be sure that no vehicle components or other vital parts could be damaged by the drilling process. Check both sides of the mounting surface before drilling begins. Also de-burr the holes and remove any metal shards or remnants. Install grommets into all wire passage holes.**
- **If this manual states that this product may be mounted with suction cups, magnets, tape or Velcro®, clean the mounting surface with a 50/50 mix of isopropyl alcohol and water and dry thoroughly.**
- **Do not install this product or route any wires in the deployment area of your air bag. Equipment mounted or located in the air bag deployment area will damage or reduce the effectiveness of the air bag, or become a projectile that could cause serious personal injury or death. Refer to your vehicle owner's manual for the air bag deployment area. The User/Installer assumes full responsibility to determine proper mounting location, based on providing ultimate safety to all passengers inside the vehicle.**
- **For this product to operate at optimum efficiency, a good electrical connection to chassis ground must be made. The recommended procedure requires the product ground wire to be connected directly to the NEGATIVE (-) battery post (this does not include products that use cigar power cords).**
- **If this product uses a remote device for activation or control, make sure that this device is located in an area that allows both the vehicle and the device to be operated safely in any driving condition.**
- **Do not attempt to activate or control this device in a hazardous driving situation.**
- **This product contains either strobe light(s), halogen light(s), high-intensity LEDs or a combination of these lights. Do not stare directly into these lights. Momentary blindness and/or eye damage could result.**
- **Use only soap and water to clean the outer lens. Use of other chemicals could result in premature lens cracking (crazing) and discoloration. Lenses in this condition have significantly reduced effectiveness and should be replaced immediately. Inspect and operate this product regularly to confirm its proper operation and mounting condition. Do not use a pressure washer to clean this product.**
- **It is recommended that these instructions be stored in a safe place and referred to when performing maintenance and/or reinstallation of this product.**
- **FAILURE TO FOLLOW THESE SAFETY PRECAUTIONS AND INSTRUCTIONS COULD RESULT IN DAMAGE TO THE PRODUCT OR VEHICLE AND/OR SERIOUS INJURY TO YOU AND YOUR PASSENGERS!**

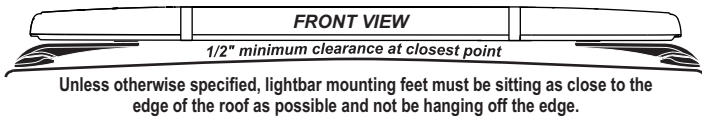

IMPORTANT! The lightbar must be a minimum of 16" from any radio antennas.

NOTE: There may be a roof support member that spans the distance between the driver's and passengers side. **DO NOT DRILL THROUGH THIS MEMBER!** Adjust the location until the holes can be drilled without contacting this support member.

IMPORTANT: For strap mounted lightbars, be sure you have the right sized bar for your vehicle. The lightbar should be approximately the same width as the vehicle roof. If too large or small it will not mount properly to the vehicle and may come loose during driving.

Strap Mounting:

1. Secure the mounting bracket to the mounting foot using the supplied FLAT WASHERS and ELASTIC STOP NUTS. Leave the mounting hardware loose enough so you can slide the two heads of the carriage bolts into the tracks in the bottom of the lightbar base extrusion. Do NOT install the optional spacers yet (Fig. 1).
2. Install the mounting foot onto the lightbar extrusion by sliding the heads of the two carriage bolts you installed into the two tracks in the bottom of the extruded base (Fig. 1).

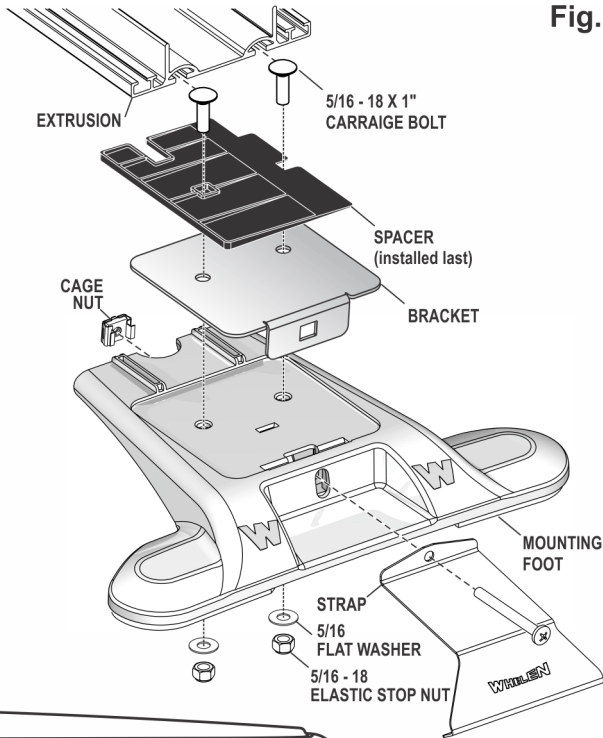
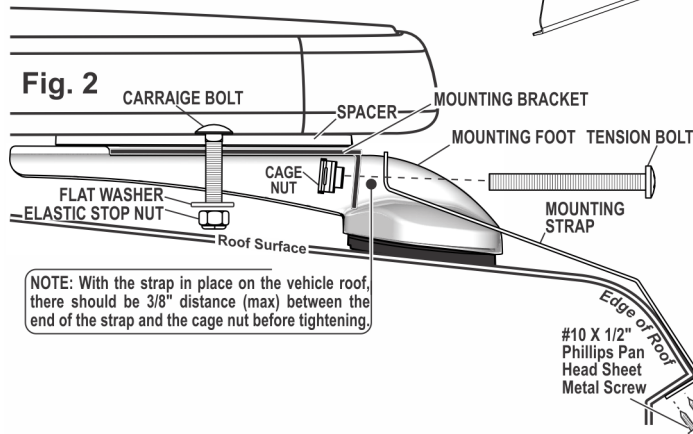
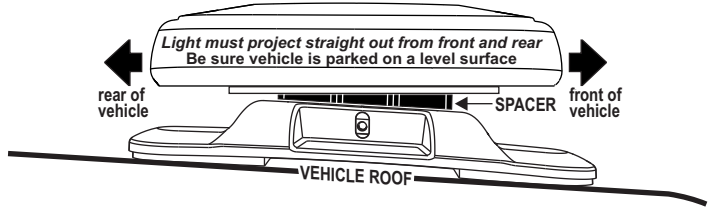

Fig. 1



NOTE: With the strap in place on the vehicle roof, there should be 3/8" distance (max) between the end of the strap and the cage nut before tightening.

3. Slide the bracket to the outer end of the base extrusion and secure the bracket to the extrusion by tightening the elastic stop nuts. Repeat steps 1 - 3 for other side of lightbar.



4. **Installing Spacers:** Spacers are used as required to adjust the lightbars clearance from the vehicle roof. Spacers are also used to make the lightbar level with the road so that the light does not project up or down when viewed from the front or rear of the vehicle. Each spacer creates a 2° incline.

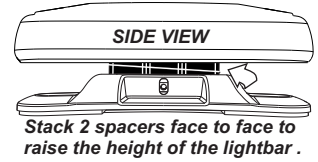

Lightbar Angle: Place the lightbar onto the vehicle roof in its exact mounting location and use a level to check the angle of the lightbar. If (because of the curvature of the vehicle roof) the front and rear lights project up or down, you will need to install one of the supplied spacers. Note the angle of the tilt to determine where to place the spacer. **Installation:** Remove the mounting feet and install the spacer (maximum 1 per side) then reinstall the feet.

Distance from roof: The lightbar must be no closer than 1/2 inch (at the closest point) from the vehicle roof. **Installation:** Remove the mounting feet, install the spacers as shown (maximum 2 per side) and reinstall feet.

5. With the lightbar in position on the vehicle, slide the end of the mounting strap (with the single hole) into the mounting foot as shown and loosely secure it to the foot with the tension bolt (Fig. 2). **NOTE:** When the opposite end of the strap (which mounts to the vehicle) is in its mounting position (on the edge of the roof) the end of the strap going to the foot should be no more than 3/8" from the cage nut. If the distance from the strap to the cage nut is greater than 3/8", remove the lightbar from the vehicle and move both mounting feet the necessary distance to correct this before doing step 5.
6. Bring the outside of the mounting strap down to the edge of the vehicle roof. The outer end of the strap should hook around the roof (Fig. 2). Mounting straps are made for specific vehicles and the one designed for your vehicle will conform to the edge of that roof.
7. Make sure the strap is in position on the edge of the roof and the other end lines up properly with the cage nut. Drill two holes for a #10 screw through the two mounting holes in the strap and secure the strap with the two #10 X 1/2" PHILLIPS PAN HEAD SHEET METAL SCREWS.
8. Tighten the tension bolt firmly to secure the foot to the vehicle.

IMPORTANT! It is the responsibility of the installation technician to make sure that the installation and operation of this product will not interfere with or compromise the operation or efficiency of any vehicle equipment! Before returning the vehicle to active service, visually confirm the proper operation of this product, as well as all vehicle components/equipment.

Permanent Mounting:

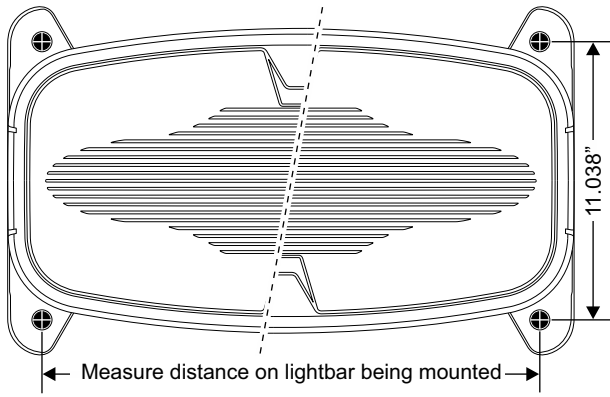

Caution: Permanent mounting of this product will require drilling. It is absolutely necessary to make sure that no other vehicle components could be damaged by this process. Check both sides of the mounting surface before starting. If damage is likely, select a different mounting location.

1. Install the mounting foot to the lightbar following steps 1 thru 4 of "Strap Mounting".

Routing the Lightbar Cable(s):

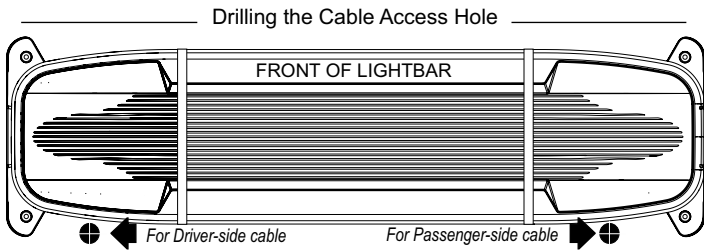

1. To protect the headliner from damage caused by drilling the cable access hole through the vehicle roof, allow a 5" to 7" distance between roof and headliner by lowering the headliner before drilling.
2. Using a 1" hole saw, drill the cable access hole then use a round file to smooth and de-burr the edges of the hole. Install a 1" grommet (user supplied).

2. Drill two holes in each mounting foot as shown to accommodate the permanent mount hardware.
3. Position the lightbar onto the vehicle in its exact mounting location and mark the location of the mounting holes onto the surface of the roof using the mounting feet as templates.
4. Remove the lightbar and drill the 4 mounting holes.
5. Install the lightbar using the supplied 1/4 - 20 Socket Head Machine Screw, 1/4" Internal Tooth Lock Washer and 1/4 - 20 X 7/16 Hex Nut.

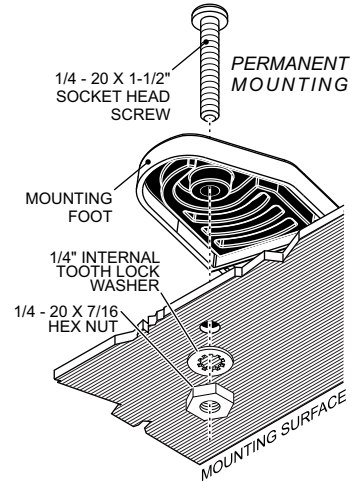

IMPORTANT! It is the responsibility of the installation technician to make sure that the installation and operation of this product will not interfere with or compromise the operation or efficiency of any vehicle equipment! Before returning the vehicle to active service, visually confirm the proper operation of this product, as well as all vehicle components/equipment.

NOTE: There may be a roof support member that spans the distance between the driver's and passenger's side. **DO NOT DRILL THROUGH THIS MEMBER!** Adjust the location until the hole can be drilled without contacting this support member.

3. Insert the cable(s) through the cable access hole into the vehicle. Use RTV silicone to weatherproof the access hole after the cable(s) are pulled completely into the vehicle.
4. Route the cable(s) one at a time to their respective destinations (power cable to vehicle battery; control cable to switch panel). Refer to the instructions included with your switches for switch wiring information.

IMPORTANT AIR BAG WARNING! Refer to front cover for necessary air bag precautions.

Control Cable Operation / HC:

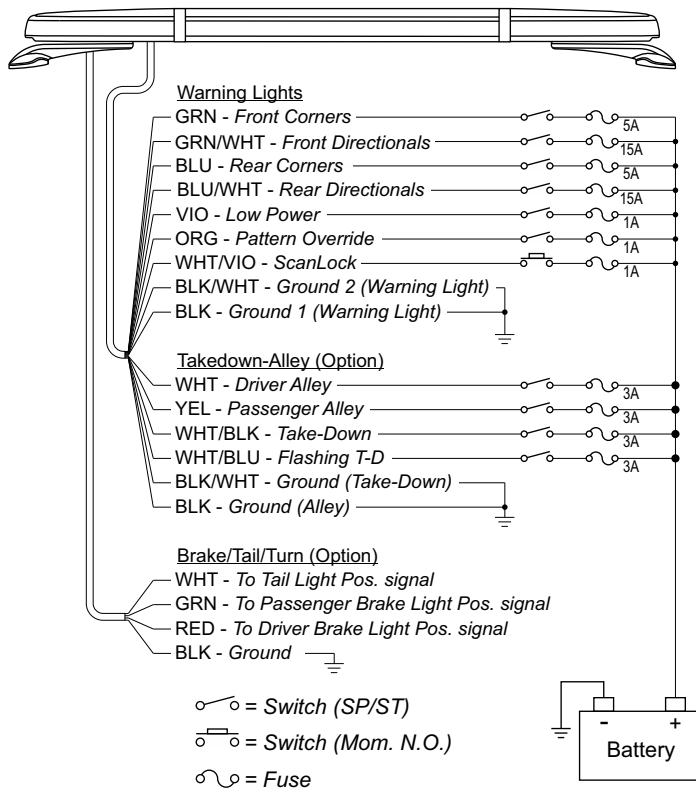

Warning Light Functions:

GRN: Front Corners (Fuse wire @ 5 AMPS)

Applying +VBAT to the GRN wire activates the Front Corners.

GRN/WHT: Front Directionals (Fuse wire @ 15 AMPS)

Applying +VBAT to the GRN/WHT wire activates the Front Directionals.

BLUE: Rear Corners (Fuse wire @ 5 AMPS)

Applying +VBAT to the BLUE wire activates the Rear Corners.

BLU/WHT: Rear Directionals (Fuse wire @ 15 AMPS)

Applying +VBAT to the BLU/WHT wire activates the Rear Directionals.

VIOLET: Low Power (Fuse wire @ 1 AMP)

ORANGE: Pattern Override (Fuse wire @ 1 AMPS)

Applying +VBAT to the ORANGE wire while lighthoods are activated, will change the flash pattern to whatever pattern override is programmed for. To program the flash pattern activate the lightbar then activate pattern override by applying +VBAT to the ORANGE wire and select a flash pattern using Scan-Lock™.

Available Flash Patterns:

- SignalAlert™ - L/R SYNC
- SignalAlert™ - L/R ASYNC
- SignalAlert™ - IN/OUT
- SignalAlert™ - SIM
- SignalAlert™ - ALT/SIM
- CometFlash® - L/R SYNC
- CometFlash® - L/R ASYNC
- CometFlash® - IN/OUT
- CometFlash® - SIM
- CometFlash® - ALT/SIM
- DoubleFlash 75 - L/R SYNC
- DoubleFlash 75 - L/R ASYNC
- DoubleFlash 75 - IN/OUT
- DoubleFlash 75 - SIM

- DoubleFlash 75 - ALT/SIM
- SignalFlash 75 - L/R SYNC
- SignalFlash 75 - L/R ASYNC
- SignalFlash 75 - IN/OUT
- SignalFlash 75 - SIM
- SignalFlash 75 - ALT/SIM
- LongBurst™ - L/R SYNC
- LongBurst™ - L/R ASYNC
- LongBurst™ - IN/OUT
- LongBurst™ - SIM
- LongBurst™ - ALT/SIM
- SingleFlash 60 - L/R SYNC
- SingleFlash 60 - L/R ASYNC
- SingleFlash 60 - IN/OUT
- SingleFlash 60 - SIM

- SingleFlash 60 - ALT/SIM
- SingleFlash 90 - L/R SYNC
- SingleFlash 90 - L/R ASYNC
- SingleFlash 90 - IN/OUT
- SingleFlash 90 - SIM
- SingleFlash 90 - ALT/SIM
- SingleFlash 120 - L/R SYNC
- SingleFlash 120 - L/R ASYNC
- SingleFlash 120 - IN/OUT
- SingleFlash 120 - SIM
- SingleFlash 120 - ALT/SIM
- SingleFlash 240 - L/R SYNC
- SingleFlash 240 - L/R ASYNC
- SingleFlash 240 - IN/OUT
- SingleFlash 240 - SIM

- SingleFlash 240 - ALT/SIM
- ActionFlash™ - L/R SYNC
- ActionFlash™ - L/R ASYNC
- ActionFlash™ - IN/OUT
- ActionFlash™ - SIM
- Ping-Pong™ - L/R SYNC
- Ping-Pong™ - L/R ASYNC
- Ping-Pong™ - IN/OUT
- Ping-Pong™ - SIM
- ModuFlash™ - L/R SYNC
- ModuFlash™ - L/R ASYNC
- ModuFlash™ - IN/OUT
- ModuFlash™ - SIM
- DoubleFlash 125
- SingleFlash 125

L/R SYNC = Left / Right Synchronous

L/R ASYNC = Left / Right ASynchronous

SIM = Simultaneous

IN/OUT = In / Out

ALT/SIM = Alternating-Simultaneous

The type of switch used is dependent on how the operator wishes the Hi/Low feature to function:

Latching Mode: By applying +VBAT to the VIOLET wire for less than 1 sec., the power supply is "latched" into low power operation. The unit must be turned off and then back on to restore normal, Hi power operation. (Momentary Switch)

Level Mode: Applying +VBAT to the VIOLET wire for over 1 sec. holds the power supply in low power mode until voltage is removed. (Toggle Switch)

Wht/Vio: Scan-Lock™ (Fuse wire @ 1 AMP)

To change the flash pattern on any light, activate only that light.

TO CHANGE PATTERNS: To cycle forward to the next available pattern apply +VBAT to the WHITE-VIOLET wire for less than 1 second and release. To cycle back to the previous pattern apply +VBAT to the WHITE-VIOLET wire for more than 1 second and release.

TO CHANGE THE DEFAULT PATTERN: When the desired pattern is displayed, allow it to run for more than 5 seconds. The light will now display this pattern when initially activated.

TO RESTORE THE FACTORY DEFAULT PATTERN: Turn power to the light off. While applying +VBAT to the WHITE-VIOLET wire, turn power to the light on. The factory default pattern is now displayed.

Use a Normally Open Momentary Switch for Scan-Lock™ operation. Scan-Lock is also used to select from four cruise light intensities.

BLK: Ground 1 (Warning Light) - Extend to ground.

BLK/WHT: Ground 2 (Warning Light) - Extend to ground..

Take-Down/Alley Functions (Optional):

WHT: Driver Alley (Fuse wire @ 3 AMPS)

Applying +VBAT to the WHITE wire will activate the Driver Side Alley Light.

YEL: Passenger Alley (Fuse wire @ 3 AMPS)

Applying +VBAT to the YELLOW wire will activate the Passenger Side Alley Light.

WHT/BLK: TakeDowns (Fuse wire @ 3 AMPS)

Applying +VBAT to the BLK/WHT wire will activate the TakeDowns

WHT/BLU: Driver Alley (Fuse wire @ 3 AMPS)

Applying +VBAT to the WHT/BLU wire will activate the Flashing TakeDowns.

BLK: Ground (Alley Light) - Extend to ground.

BLK/WHT: Ground (Take-Down) - Extend to ground.

Brake/Tail/Turn Functions (Optional):

WHT: Tail Light

Extend this wire to the Tail Light Positive Signal.

GRN: Passenger-side Brake Light

Extend this wire to the Passenger-side Brake Light Positive signal.

RED: Driver-side Brake Light

Extend this wire to the Driver-side Brake Light Positive signal.

BLK: Ground

Extend to ground.

QTY	QTY	QTY	QTY	QTY	QTY	QTY	QTY	QTY	ITEM	PART NUMBER	DESCRIPTION
								*		01-0688434-___	CENATOR "HC" SERIES 30" LIGHTBAR
								*		01-0688434-___	CENATOR "HC" SERIES 36" LIGHTBAR
						*				01-0688434-___	CENATOR "HC" SERIES 42" LIGHTBAR
				*						01-0688434-___	CENATOR "HC" SERIES 48" LIGHTBAR
			*							01-0688434-___	CENATOR "HC" SERIES 54" LIGHTBAR
		*								01-0688434-___	CENATOR "HC" SERIES 60" LIGHTBAR
	*									01-0688434-___	CENATOR "HC" SERIES 66" LIGHTBAR
*										01-0688434-___	CENATOR "HC" SERIES 72" LIGHTBAR
-	-	-	-	-	-	-	-	1	1	11-388377-023	BASE, EXTRUSION 23.570" (30")
-	-	-	-	-	-	-	-	1	2	11-388377-029	BASE, EXTRUSION 29.535" (36")
-	-	-	-	-	-	-	-	1	3	11-388377-035	BASE, EXTRUSION 35.500" (42")
-	-	-	-	-	-	-	-	1	4	11-388377-041	BASE, EXTRUSION 41.635" (48")
-	-	-	1	-	-	-	-	-	5	11-388377-047	BASE, EXTRUSION 47.430" (54")
-	-	1	-	-	-	-	-	-	6	11-388377-053	BASE, EXTRUSION 53.396" (60")
-	1	-	-	-	-	-	-	-	7	11-388377-059	BASE, EXTRUSION 59.362" (66")
1	-	-	-	-	-	-	-	-	8	11-388377-065	BASE, EXTRUSION 65.327" (72")
1	1	1	1	1	1	1	1	1	9	11-388218-001	BASE, HOUSING END MODULE TONGUE
1	1	1	1	1	1	1	1	1	10	11-388218-002	BASE, HOUSING END MODULE GROOVE
8	7	6	5	4	3	2	1	1	11	11-388219-000	BASE, HOUSING CENTER MODULE GROOVE
84	76	68	60	52	44	36	28	28	12	15-04547B-060	SCREW, 4-3/8 TORX PAN HEAD SS BLACK OXIDE
4	4	4	4	4	4	4	4	4	13	19-16H068-__00	RETAINER, LENS MOUNT END
4	4	4	4	4	4	4	4	4	14	19-147751-000	RETAINER, SHORT LENS MOUNT END
14	12	10	8	6	4	2	-	-	15	19-147750-000	RETAINER, LONG LENS MOUNT END
1	1	1	1	1	1	1	1	1	16	21-3718996-00	HOLE PLUG, 1/32 DIA.
2	2	2	2	2	2	2	2	2	17	02-036H812-00	SUB ASSY, MOUNTING FOOT
2	2	2	2	2	2	2	2	2	18	07-288394-000	BRACKET, HEATSINK END MODULE
16	14	12	10	8	6	4	2	19	07-26H588-000	BRACKET, HEATSINK INBOARD	
40	36	32	28	24	20	16	12	20	15-081416-060	SCREW, 8 x 3/8 PPHMS SS TYPE A	
40	36	32	28	24	20	16	12	21	21-17060704-3	GROMMET	
A/R	A/R	A/R	A/R	A/R	A/R	A/R	A/R	A/R	22	01-026H800-*0	SUB ASSY, 3 LED SOLO LIR3
A/R	A/R	A/R	A/R	A/R	A/R	A/R	A/R	A/R	23	01-026H819-*0	SUB ASSY, 6 LED LINEAR SOLO LIN6+
A/R	A/R	A/R	A/R	A/R	A/R	A/R	A/R	A/R	24	01-026H818-*0	SUB ASSY, 6 LED LINEAR SOLO LIN6
A/R	A/R	A/R	A/R	A/R	A/R	A/R	A/R	A/R	25	01-0247958-30	SUB ASSY, TAKEDOWN/ALLEY 3 LED
A/R	A/R	A/R	A/R	A/R	A/R	A/R	A/R	A/R	26	01-0247941-30	SUB ASSY, TAKEDOWN/ALLEY 1 LED
20	18	16	14	12	10	8	6	27	07-26H813-000	BRACKET, FILLER	
A/R	A/R	A/R	A/R	A/R	A/R	A/R	A/R	A/R	28	14-040285-063	SCREW, 4-40 x 3/8 TORX PH TRILOBULAR SS BLK
A/R	A/R	A/R	A/R	A/R	A/R	A/R	A/R	A/R	29	68-196H600-___	LENS, OPTIC FILTER
-	-	-	-	1	-	-	-	-	30	68-1988221-___	LENS, OPTIC CENTER MOD
-	-	-	2	-	-	-	-	1	31	68-19883981-___	LENS/OPTIC ONE MODULE, 5.65" LONG
1	2	3	-	-	-	-	4	-	32	68-19883982-___	LENS/OPTIC TWO MODULE, 11.62" LONG
2	1	-	1	-	1	-	-	-	33	68-19883983-___	LENS/OPTIC THREE MODULE, 17.59" LONG
8	8	8	8	4	4	4	4	4	34	38-046H072-00	SEAL, LENS DIVIDER
4	4	4	4	2	2	2	2	2	35	39-046H071-___	DIVIDER, LENS
2	2	2	2	2	2	2	2	2	36	68-1988220-___	LENS, OPTIC END MODULE
4	4	4	4	4	4	4	4	4	37	21-17020602-3	SCREW, GROMMET
2	2	2	2	2	2	2	2	2	38	11-26H069-000	ENDCAP, END MODULE LENS
4	4	4	4	4	4	4	4	4	39	15-045410-100	SCREW, 4 X 5/8 PPH

LIGHTHEAD OPTIONS

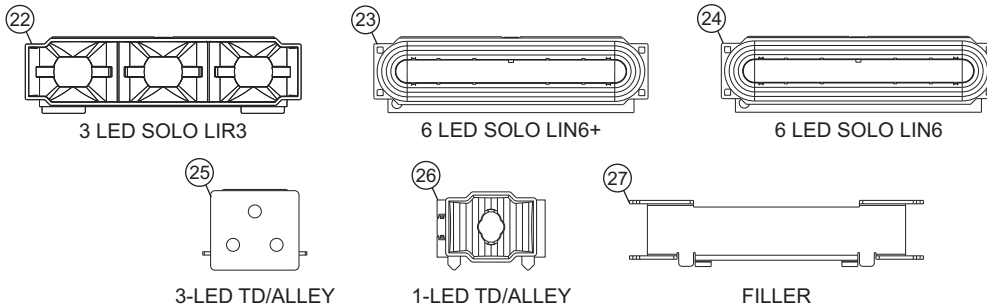

CENATOR™ LIGHTBAR LAYOUTS

