

WHELEN[®]

ENGINEERING COMPANY INC.

51 Winthrop Road
Chester, Connecticut 06412-0684
Phone: (860) 526-9504
Internet: www.whelen.com
Sales e-mail: autosale@whelen.com
Customer Service e-mail: custserv@whelen.com

Installation Guide:
Dominator Plus™ Flasher Series
Models: DP2, DP4, DP6 and DP8

Warnings to Installers

Whelen's emergency vehicle warning devices must be properly mounted and wired in order to be effective and safe. Read and follow all of Whelen's written instructions when installing or using this device. Emergency vehicles are often operated under high speed stressful conditions which must be accounted for when installing all emergency warning devices. Controls should be placed within convenient reach of the operator so that they can operate the system without taking their eyes off the roadway. Emergency warning devices can require high electrical voltages and/or currents. Properly protect and use caution around live electrical connections. Grounding or shorting of electrical connections can cause high current arcing, which can cause personal injury and/or vehicle damage, including fire. Many electronic devices used in emergency vehicles can create or be affected by electromagnetic interference. Therefore, after installation of any electronic device it is necessary to test all electronic equipment simultaneously to insure that they operate free of interference from other components within the vehicle. Never power emergency warning equipment from the same circuit or share the same grounding circuit with radio communication equipment. All devices should be mounted in accordance with the manufacturer's instructions and securely fastened to vehicle elements of sufficient strength to withstand the forces applied to the device. Driver and/or passenger air bags (SRS) will affect the way equipment should be mounted. This device should be mounted by permanent installation and within the zones specified by the vehicle manufacturer, if any. Any device mounted in the deployment area of an air bag will damage or reduce the effectiveness of the air bag and may damage or dislodge the device. Installer must be sure that this device, its mounting hardware and electrical supply wiring does not interfere with the air bag or the SRS wiring or sensors. Mounting the unit inside the vehicle by a method other than permanent installation is not recommended as unit may become dislodged during swerving; sudden braking or collision. Failure to follow instructions can result in personal injury. Whelen assumes no liability for any loss resulting from the use of this warning device. **PROPER INSTALLATION COMBINED WITH OPERATOR TRAINING IN THE PROPER USE OF EMERGENCY WARNING DEVICES IS ESSENTIAL TO INSURE THE SAFETY OF EMERGENCY PERSONNEL AND THE PUBLIC.**

Warnings to Users

Whelen's emergency vehicle warning devices are intended to alert other operators and pedestrians to the presence and operation of emergency vehicles and personnel. However, the use of this or any other Whelen emergency warning device does not guarantee that you will have the right-of-way or that other drivers and pedestrians will properly heed an emergency warning signal. Never assume you have the right-of-way. It is your responsibility to proceed safely before entering an intersection, driving against traffic, responding at a high rate of speed, or walking on or around traffic lanes. Emergency vehicle warning devices should be tested on a daily basis to ensure that they operate properly. When in actual use, the operator must ensure that both visual and audible warnings are not blocked by vehicle components (i.e.: open trunks or compartment doors), people, vehicles, or other obstructions. It is the user's responsibility to understand and obey all laws regarding emergency warning devices. The user should be familiar with all applicable laws and regulations prior to the use of any emergency vehicle warning device. Whelen's audible warning devices are designed to project sound in a forward direction away from the vehicle occupants. However, because sustained periodic exposure to loud sounds can cause hearing loss, all audible warning devices should be installed and operated in accordance with the standards established by the National Fire Protection Association.

Safety First

This document provides all the necessary information to allow your Whelen product to be properly and safely installed. Before beginning the installation and/or operation of your new product, the installation technician and operator must read this manual completely. Important information is contained herein that could prevent serious injury or damage.

⚠ WARNING: This product can expose you to chemicals including Methylene Chloride which is known to the State of California to cause cancer, and Bisphenol A, which is known to the State of California to cause birth defects or other reproductive harm. For more information go to www.P65Warnings.ca.gov.

- **Proper installation of this product requires the installer to have a good understanding of automotive electronics, systems and procedures.**
- **Whelen Engineering requires the use of waterproof butt splices and/or connectors if that connector could be exposed to moisture.**
- **Any holes, either created or utilized by this product, should be made both air- and watertight using a sealant recommended by your vehicle manufacturer.**
- **Failure to use specified installation parts and/or hardware will void the product warranty.**
- **If mounting this product requires drilling holes, the installer MUST be sure that no vehicle components or other vital parts could be damaged by the drilling process. Check both sides of the mounting surface before drilling begins. Also de-burr the holes and remove any metal shards or remnants. Install grommets into all wire passage holes.**
- **If this manual states that this product may be mounted with suction cups, magnets, tape or Velcro®, clean the mounting surface with a 50/50 mix of isopropyl alcohol and water and dry thoroughly.**
- **Do not install this product or route any wires in the deployment area of your air bag. Equipment mounted or located in the air bag deployment area will damage or reduce the effectiveness of the air bag, or become a projectile that could cause serious personal injury or death. Refer to your vehicle owner's manual for the air bag deployment area. The User/Installer assumes full responsibility to determine proper mounting location, based on providing ultimate safety to all passengers inside the vehicle.**
- **For this product to operate at optimum efficiency, a good electrical connection to chassis ground must be made. The recommended procedure requires the product ground wire to be connected directly to the NEGATIVE (-) battery post (this does not include products that use cigar power cords).**
- **If this product uses a remote device for activation or control, make sure that this device is located in an area that allows both the vehicle and the device to be operated safely in any driving condition.**
- **Do not attempt to activate or control this device in a hazardous driving situation.**
- **This product contains either strobe light(s), halogen light(s), high-intensity LEDs or a combination of these lights. Do not stare directly into these lights. Momentary blindness and/or eye damage could result.**
- **Use only soap and water to clean the outer lens. Use of other chemicals could result in premature lens cracking (crazing) and discoloration. Lenses in this condition have significantly reduced effectiveness and should be replaced immediately. Inspect and operate this product regularly to confirm its proper operation and mounting condition. Do not use a pressure washer to clean this product.**
- **It is recommended that these instructions be stored in a safe place and referred to when performing maintenance and/or reinstallation of this product.**
- **FAILURE TO FOLLOW THESE SAFETY PRECAUTIONS AND INSTRUCTIONS COULD RESULT IN DAMAGE TO THE PRODUCT OR VEHICLE AND/OR SERIOUS INJURY TO YOU AND YOUR PASSENGERS!**

Specifications:

Input Voltage 12.8 VDC +/- 20%
 Input Current for each lighthouse / Sim.....Peak - .75 Amps
 Input Current for each lighthouse / Alt.....Peak - .3 Amps
 For your lightbar's input current, multiply by the amount of lighthouses in your lightbar.
 Input Sync..... Active Low
 Sync Phase..... Phase I & II @ 400ms
 Input Scan-Lock™ +12 VDC @ 20 ma

Installation:

Note: When routing the wires, it is very important that you choose a path that will keep the wires away from excessive heat or any vehicle equipment that could compromise the integrity of the wires (ex. trunk lids, door jams, etc.).

End view of extrusion with endcap removed.

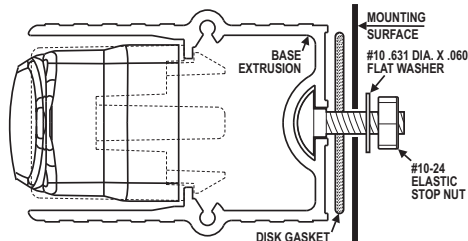

Note: Permanent mounting of this product will require drilling. It is absolutely necessary to make sure that no other vehicle components could be damaged by this process. Check both sides of the mounting surface before starting. If damage is likely, select a different mounting location.

IMPORTANT! The lightbar should be a minimum of 16" from any radio antennas!

1. Position the unit in its proposed mounting location. Draw a pencil line onto the mounting surface along the top and bottom of the extrusion and a "centerline" centered between the two.
2. Two 1/4" holes are required to mount this unit. These holes may be located anywhere along the horizontal centerline that you drew in step one. It's best to locate the holes as far apart as possible. Mark the hole location onto the mounting surface.
3. Using a 1/4" drill bit, drill a hole in each of the areas scribed in the previous step.
4. Slide the 2 carriage bolts (installed in the rear of the bar) over to the 2 mounting holes. Install the rubber gaskets onto the bolts and insert them into the mounting holes.
5. Secure the unit by threading the flat washer and elastic stop nut onto each bolt and tightening them firmly.

Wiring:

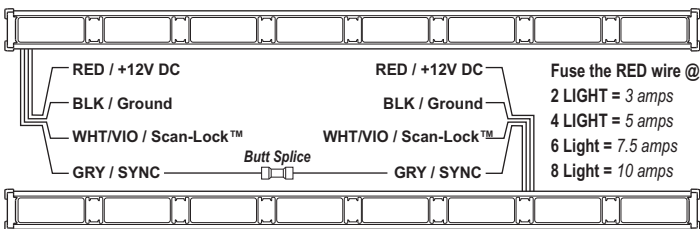

WARNING: All customer supplied wires that connect to the positive terminal of the battery must be sized to supply at least 125% of the maximum operating current and **FUSED** at the battery to carry that load. **DO NOT USE CIRCUIT BREAKERS WITH THIS PRODUCT!**

Operation: White/Violet / Scan-Lock™

Scan-Lock™ allows you to choose from several flash patterns. To change a flash pattern, turn on the desired lighthouse:

CYCLE THROUGH ALL PATTERNS: To cycle forward, apply +12 volts to the WHITE/VIOLET wire for less than 1 second and release. To cycle backward, apply +12 volts to the WHITE/VIOLET wire for more than 1 second and release.

SET A PATTERN AS DEFAULT: When the desired pattern is displayed, allow it to run for more than 5 seconds. The lighthouse will now display this pattern when active.

RESET TO THE FACTORY DEFAULT PATTERN: Turn off power and apply +12 volts to the WHITE/VIOLET wire while turning power back on.

Note: If you wish to connect the pattern selection wire (WHITE/VIOLET) to a switch, an SPST momentary switch is recommended.

IMPORTANT WARNING!

CAUTION! DO NOT LOOK DIRECTLY AT THESE LEDS WHILE THEY ARE ON. MOMENTARY BLINDNESS AND/OR EYE DAMAGE COULD RESULT!

Available Scan-Lock™ Flash Patterns:

Grey / SYNC:

- | | | |
|---------------------------|--------------------|--------------------|
| 4, 6 & 8 Lamp: | 7. ZigZag 60 | 3. SingleFlash 375 |
| 1. SignalAlert™ 75 | 8. ZigZag 90 | 4. SingleFlash 75 |
| 2. CometFlash® 75 | 9. ZigZag 120 | 5. ActionFlash™ |
| 3. SingleFlash 375 | 10. ActionScan™ | 6. ModuFlash™ |
| 4. SingleFlash 75 | | 7. ActionScan™ |
| 5. ActionFlash™ | 2 Lamp: | |
| 6. ModuFlash™ | 1. SignalAlert™ 75 | |
| | 2. CometFlash® 75 | |

As an example, we will synchronize two 2 lighthouse Dominators™. The 2 lighthouse Dominator™ has 4 unique modes for each of the 4 flash patterns that can be synchronized; Alternating Phase 1, Alternating Phase 2, Simultaneous Phase 1 and Simultaneous Phase 2.

In Alternating Mode: The left lightbar alternates with the right lightbar.

In Simultaneous Mode: The left and right lightbars flash simultaneously.

Synchronized lightbars, must be set to the same pattern. Not all patterns can be synchronized.

EXAMPLE: Two, 2 light Dominators™ mounted on the rear deck.

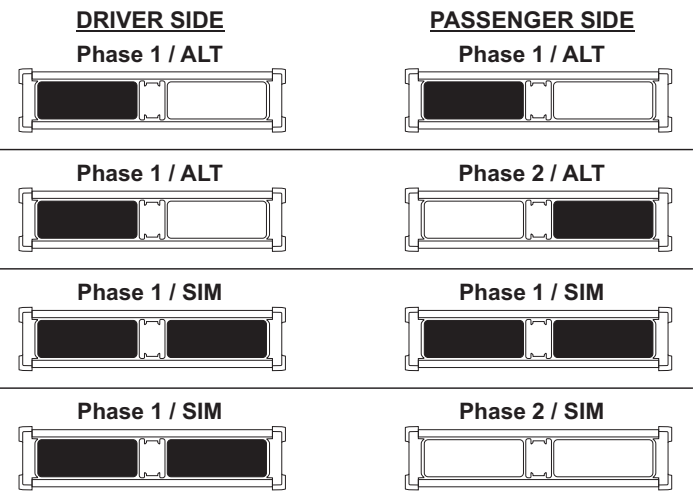

Available Sync Patterns

4, 6 & 8 Lamp Arrays

SignalAlert™ 75 Alt. - In-Out - Checker Board - Sim. Phase I - Sim. Phase II
 CometFlash® 75 Alt. - In-Out - Checker Board - Sim. - Phase I - Sim. Phase II
 SingleFlash 375 Alt. - In-Out - Checker Bd. - Sim. - Phase I - Sim. Phase II
 SingleFlash 75 Alt. - In-Out - Checker Bd. - Sim. - Phase I - Sim. Phase II

2 Lamp Array:

SignalAlert 75 Alt - Simultaneous - Phase I - Simultaneous Phase II
 CometFlash 75 Alt - Simultaneous - Phase I - Simultaneous Phase II
 SingleFlash 375 Alt - Simultaneous - Phase I - Simultaneous Phase II
 SingleFlash 75 Alt - Simultaneous - Phase I - Simultaneous Phase II

IMPORTANT! Before returning the vehicle to active service, visually confirm the proper operation of this product, as well as all vehicle components/equipment.

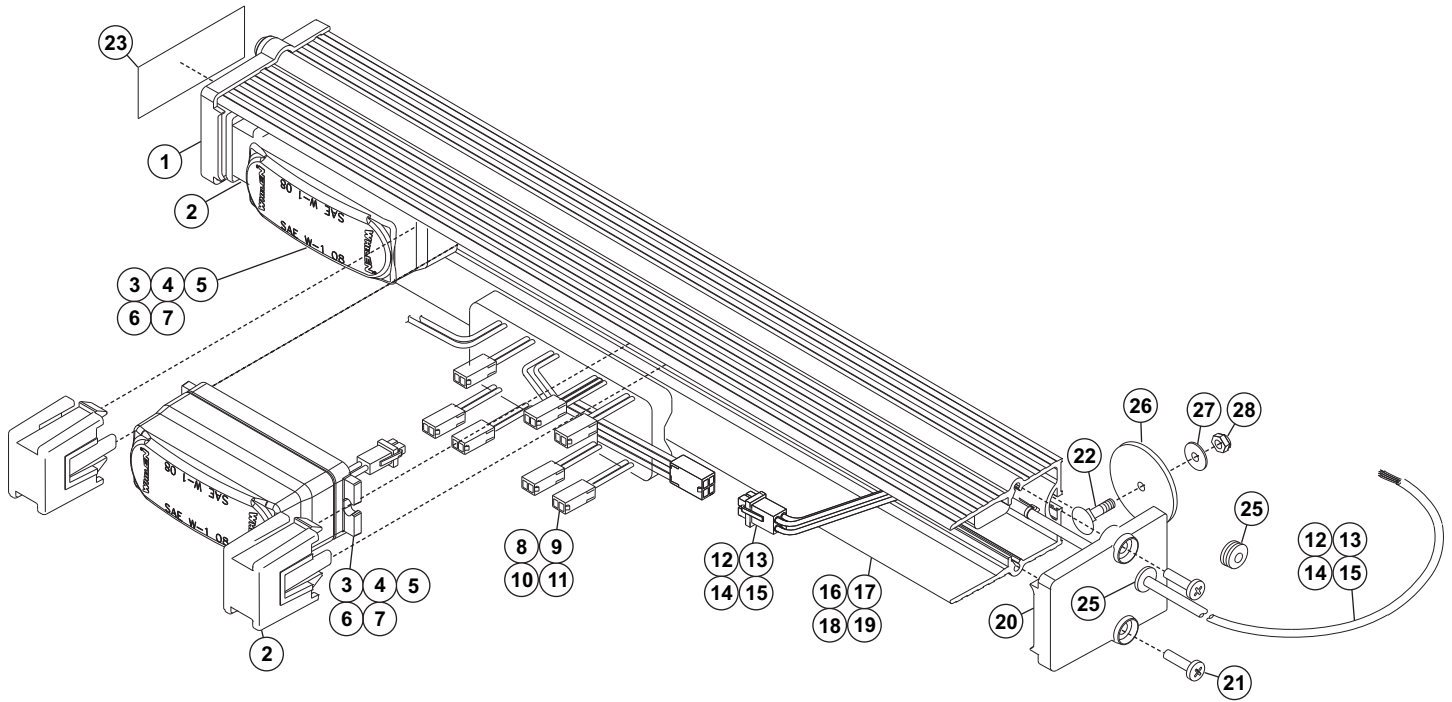

QTY	QTY	QTY	QTY	ITEM	PART NUMBER	DESCRIPTION	"A"
			*		01-0688637-02	DOMINATOR PLUS, FLASHER - 2 LT	7.11
			*		01-0688637-04	DOMINATOR PLUS, FLASHER - 4 LT	14.21
		*			01-0688637-06	DOMINATOR PLUS, FLASHER - 6 LT	23.26
		*			01-0688637-08	DOMINATOR PLUS, FLASHER - 8 LT	30.36
1	1	1	1	1	11-263726-000	ENDCAP, (3)TIR EXTR. MT. W/O HOLE	
9	7	3	1	2	38-0463725-00	DIVIDER, EXTRUSION MOUNT	
OPT	OPT	OPT	OPT	3	01-0287905214	LTHEAD ASSY, LINZ6 - AMB/STDY	
OPT	OPT	OPT	OPT	4	01-0287905224	LTHEAD ASSY, LINZ6 - BLU/STDY	
OPT	OPT	OPT	OPT	5	01-0287905234	LTHEAD ASSY, LINZ6 - WHT/STDY	
OPT	OPT	OPT	OPT	6	01-0287905244	LTHEAD ASSY, LINZ6 - GREEN/STDY	
OPT	OPT	OPT	OPT	7	01-0287905254	LTHEAD ASSY, LINZ6 - RED/STDY	
-	-	-	-	8	01-0264929-01	ELECT. ASSY, 2 LIGHTHEAD FLASHER	
-	-	-	-	9	01-0269777-A4	ELECT. ASSY, 4 LIGHTHEAD FLASHER	
-	-	-	-	10	01-0269777-A6	ELECT. ASSY, 6 LIGHTHEAD FLASHER	
1	-	-	-	11	01-0269777-A8	ELECT. ASSY, 8 LIGHTHEAD FLASHER	
-	-	-	-	12	46-0743087-A2	CABLE ASSY, W/ MINI UMNL CONN. 13"	
-	-	-	-	13	46-0743087-A4	CABLE ASSY, W/ MINI UMNL CONN. 17"	
-	-	-	-	14	46-0743087-A6	CABLE ASSY, W/ MINI UMNL CONN. 20"	
1	-	-	-	15	46-0743087-A8	CABLE ASSY, W/ MINI UMNL CONN. 24"	
-	-	-	-	16	11-443031-006	EXTRUSION, MACH'D - 6.75 3TIR TA	
-	-	-	-	17	11-443031-013	EXTRUSION, MACH'D - 13.85 3TIR TA	
-	-	-	-	18	11-443031-022	EXTRUSION, MACH'D - 22.90 3TIR TA	
1	-	-	-	19	11-443031-030	EXTRUSION, MACH'D - 30.00 3TIR TA	
1	1	1	1	20	11-263726-002	ENDCAP(3)TIR EXTR. MT. W/ .375 HOLE	
4	4	4	4	21	14-062219-06D	SCREW, #6-32 X 3/8 PPHMS ROLOK ZN	
2	2	2	2	22	14-104066-100	CARRIAGE BOLT, #10-24 X 5/8 LG SS	
1	1	1	1	23	10-0548197-__	LABEL, DOMINATOR PLUS	
1	1	1	1	24	10-0326475-05	LABEL, R10	
2	2	2	2	25	21-11091202-0	GROMMET,	
2	2	2	2	26	38-0223063-00	GASKET, DISK	
2	2	2	2	27	16-1002220-50	WASHER, #10 FLAT .631 DIA. X .060	
2	2	2	2	28	13-104120-062	NUT, #10-24 ELASTIC STOP	