



**FEDERAL SIGNAL**  
Safety and Security Systems

# Navigator<sup>®</sup> Light Bar



---

## *Installation, Operation, and Service Instructions*

## Limited Warranty

This product is subject to and covered by a limited warranty, a copy of which can be found at [www.fedsig.com/SSG-Warranty](http://www.fedsig.com/SSG-Warranty). A copy of this limited warranty can also be obtained by written request to Federal Signal Corporation, 2645 Federal Signal Drive, University Park, IL 60484, email to [info@fedsig.com](mailto:info@fedsig.com) or call +1 708-534-3400.

This limited warranty is in lieu of all other warranties, express or implied, contractual or statutory, including, but not limited to the warranty of merchantability, warranty of fitness for a particular purpose and any warranty against failure of its essential purpose.



## FEDERAL SIGNAL

Safety and Security Systems

2645 Federal Signal Drive  
University Park, Illinois 60484

[www.fedsig.com](http://www.fedsig.com)

Customer Support

Police/Fire-EMS: 800-264-3578 • +1 708 534-3400

Work Truck: 800-824-0254 • +1 708 534-3400

Technical Support 800-433-9132 • +1 708 534-3400

---

## Contents

<b>Safety Messages to Installers Warning Light Equipment.....</b>	<b>5</b>
<b>Safety Messages to Operators .....</b>	<b>7</b>
<b>Overview of the Light Bar .....</b>	<b>9</b>
Solaris LED Reflector Technology.....	9
LED Rotating Lights.....	9
QuadraFlare LED Stationary Lights .....	10
Control Options.....	10
Mount Options .....	10
<b>Preparing for the Light Bar Installation.....</b>	<b>11</b>
Unpacking the Light Bar.....	11
<b>Programming the Light Bar .....</b>	<b>11</b>
Flashing Modes .....	11
<b>Selecting Flash Patterns.....</b>	<b>11</b>
Selecting a Flash Pattern with the Orange Lead in the Control Cable .....	12
Selecting a Flash Pattern with the Button.....	12
<b>Changing the Features on a 45-inch, 53-inch and 60-inch Navigator .....</b>	<b>15</b>
<b>Changing the Rotator Functions in an All-Rotator Navigator .....</b>	<b>16</b>
<b>Determining the Mounting Location and Wire Routing .....</b>	<b>17</b>
<b>Wiring the Navigator in the Vehicle .....</b>	<b>18</b>
<b>Connecting Power to the Light Bar .....</b>	<b>20</b>
10-inch All-Stationary Navigator with a 4-Conductor Control Cable.....	20
10-inch or 18-inch All-Rotator Navigator with a 4-Conductor Control Cable .....	21
Navigator with Power, Ground, and 5 Control Leads .....	21
Navigator with Power Ground and 10-Conductor Control Cable .....	22
Navigator with a 20-Conductor Control Cable.....	23
Navigator with Power, Ground Leads, and Serial Cable .....	26
Wiring the Navigator Stop/Tail/Turn Lights Option.....	27
<b>Navigator Light Bars with TCL option .....</b>	<b>27</b>
Selecting a TCL flash pattern.....	27
<b>Maintaining and Servicing the Navigator.....</b>	<b>28</b>
Cleaning the Domes.....	29
Cleaning the Reflectors and Mirrors.....	30
Replacing a Dome or Bulkhead.....	30
Installing Domes and Bulkheads.....	31
Replacing a Rotator Assembly.....	31
Configuring How a Rotator Operates .....	32
Replacing a Mirror .....	33
Replacing a QuadraFlare Stationary Light.....	33
Troubleshooting the Light Bar .....	34

---

<b>Replacement Parts .....</b>	<b>35</b>
<b>Getting Technical Support and Service.....</b>	<b>39</b>
Getting Repair Service.....	39

### Figures

Figure 1 Flash pattern button on control board discrete-wired Navigator.....	12
Figure 2 Central control board with switches off (down).....	15
Figure 3 All-rotator power distribution board.....	16
Figure 4 Wire functions for 4-conductor cable (10-inch all stationary).....	21
Figure 5 Wire functions for 10-conductor cable.....	22
Figure 6 Light bar functions for 20-conductor cable.....	24
Figure 7 Cable leads for stop/tail/turn lights.....	27
Figure 8 Navigator (25-inch) with the end dome disassembled .....	30
Figure 9 Navigator (25 inch) viewed from the top .....	31
Figure 10 Location of SW1 DIP switch for rotator operation .....	32

### Tables

Table 1 Dimensions in inches (*less mounting feet) .....	10
Table 2 Light Specifications .....	10
Table 3 Flash patterns: 10-conductor discrete-wired cable .....	13
Table 4 Flash patterns: 45 in, 53 in, and 60 in serial-controlled/discrete light bar .....	14
Table 5 Functions of SW4.....	15
Table 6 Cabling based on light bar length and configuration (see pages referenced) .....	19
Table 7 Light bar functions for 10-conductor cable.....	23
Table 8 Light bar functions for 20-conductor cable .....	25
Table 9 Light bar functions for 10-inch Navigator cable .....	26
Table 10 TCL Flash Patterns .....	28
Table 11 Table 12 DIP switch settings for rotator operation.....	32
Table 12 Troubleshooting tips.....	34
Table 13 6 x 4 light heads for use with 6-conductor cable .....	35
Table 14 6 x 4 light heads for use with 8-conductor cable.....	35
Table 15 6 x 4 light heads for use with 10-conductor cable.....	36
Table 16 7 x 3 light heads for use with 6-conductor cable.....	36
Table 17 4 x 3 light heads for use with 6-conductor cable.....	37
Table 18 LED rotators.....	37
Table 19 Mirrors .....	37
Table 20 Internal cables.....	38
Table 21 Internal light bar controllers and mini jumper .....	38
Table 22 Bulkheads and domes .....	38
Table 23 End caps .....	39

## **Safety Messages to Installers Warning Light Equipment**

### **▲ WARNING**

People's lives depend on your proper installation and servicing of Federal Signal products. It is important to read and follow all instructions shipped with this product and the original product. Listed below are some other important safety instructions and precautions you should follow:

#### **Before Installation or Service**

##### *Qualifications*

- To properly install or service this equipment, you must have a good understanding of automotive mechanical and electrical procedures and systems, along with proficiency in the installation and service of safety warning equipment. Always refer to the vehicle's service manuals when performing equipment installations on a vehicle.

##### *Light Hazards*

- In order to be an effective warning device, this product produces bright light that can be hazardous to your eyesight when viewed at a close range. Do not stare directly into this lighting product at a close range, or permanent damage to your eyesight may occur.
- Do not install the light system in an area that would block, impair, or blind the driver's vision. Ensure that the light system is mounted in a position that is outside the driver's field of vision, so the driver can maintain safe vehicle operation.
- Federal Signal power supplies and light heads are designed to work together as a system. Combining light heads and a power supply from different manufacturers may reduce the warning effectiveness of the lighting system and may damage the components. Verify or test your combination to ensure that the system works together and meets federal, state, and local standards or guidelines.

##### *Electrical Hazards*

- A light system is a high current system. In order for the system to function properly, a separate negative (-) connection and positive (+) connection must be made. All negative connections should be connected to the negative battery terminal, and a suitable fuse should be installed on the positive battery terminal connection as close to the battery as possible. Ensure that all wires and fuses are rated correctly to handle the device and system amperage requirements.
- Never attempt to install aftermarket equipment that connects to the vehicle wiring without reviewing a vehicle wiring diagram available from the vehicle manufacturer. Ensure that your installation will not affect vehicle operation or mandated safety functions or circuits. Always check the vehicle for proper operation after installation.
- The lighting system components, especially LEDs and the outer housing, get hot during operation. Be sure to disconnect power to the system and allow the system to cool down before handling any components of the system.
- Do not mount a radio antenna within 18 inches of the lighting system. Placing the antenna too close to the lighting system could cause the lighting system to

malfunction or be damaged by strong radio fields. Mounting the antenna too close to the lighting system may also cause the radio noise emitted from the lighting system to interfere with the reception of the radio transmitter and reduce radio reception.

- Do not attempt to wash this or any other electrical device while it is connected to its power source. Exposure to liquid while the product is connected to the power source may result in an electrical shock and personal injury, and may short circuit and damage the product.

### **During Installation and Service**

- DO NOT get metal shavings inside the product. Metal shavings in the product can cause the system to fail. If drilling must be done near the unit, place an ESD-approved cover over the unit. Inspect the unit after mounting to ensure that there are no shavings present in or near the unit.
- To avoid a battery explosion, always disconnect the negative battery cable first and reconnect it last. Avoid causing a spark when connecting near or to the battery. The gases produced by a battery can cause a battery explosion that could result in vehicle damage and serious injury.
- DO NOT connect this system to the vehicle battery until ALL other electrical connections are made, mounting of all components is complete, and you have verified that no shorts exist. If the wiring is shorted to the vehicle body or frame, high current conductors can cause hazardous sparks, resulting in electrical fires or flying molten metal.
- DO NOT install equipment or route wiring (or the plug-in cord) in the deployment path of an airbag.
- If a vehicle seat is temporarily removed, verify with the vehicle manufacturer if the seat needs to be recalibrated for proper airbag deployment.
- Before mounting any components, check the manual to ensure that the component you are installing is suitable for use in that area of the vehicle. Many components are not suitable for use in the engine compartment or other extreme environmental exposure areas.
- When drilling into a vehicle structure, ensure that both sides of the surface are clear of anything that could be damaged. Remove all burrs from drilled holes. To prevent electrical shorts, grommet all drilled holes through which wiring passes. Ensure that the mounting screws do not cause electrical or mechanical damage to the vehicle.
- Refer to the instruction sheet packed with the lighting system for proper electrical connections, additional precautions, and information.
- Because vehicle roof construction and driving conditions vary, do not drive a vehicle with a magnetically mounted warning light installed. The light could fly off the vehicle, causing injury or damage. Repair of damage incurred because of ignoring this warning shall be the sole responsibility of the user.
- To avoid denting the roof of the vehicle, place the light bar mounting feet as close to outer edge of the roof as possible.

- Roof damage can occur if the hook adjustment bolts are overtightened. Torque the hook adjustment bolts 6 ft-lb to 7 ft-lb. Install keeper plates.
- Locate the light system controls so the VEHICLE and CONTROLS can be operated safely under all driving conditions.

#### **After Installation or Service**

- After installation, test the light system to ensure that it is operating properly.
- If a seat is temporarily removed, verify with the vehicle manufacturer if the seat needs to be recalibrated for proper airbag deployment.
- Test all vehicle functions, including horn operation, vehicle safety functions, and vehicle light systems, to ensure proper operation. Ensure that the installation has not affected the vehicle operation or changed any vehicle safety function or circuit.
- Scratched or dull reflectors, mirrors, or lenses will reduce the effectiveness of the lighting system. Avoid heavy pressure and use of caustic or petroleum-based products when cleaning the lighting system. Replace any optical components that may have been scratched or crazed during system installation.
- Do not attempt to activate or deactivate the light system control while driving in a hazardous situation.
- Frequently inspect the light system to ensure that it is operating properly and that it is securely attached to the vehicle.
- After installation and testing are complete, provide a copy of these instructions to instructional staff and all operating personnel.
- File these instructions in a safe place and refer to them when maintaining and/or reinstalling the product.
- Failure to follow all safety precautions and instructions may result in property damage, serious injury, or death.

### **Safety Messages to Operators**

#### **⚠ WARNING**

Peoples' lives depend on your safe use of our products. Listed below are some important safety instructions and precautions you should follow:

- Although your warning system is operating properly, it may not be completely effective. People may not see or heed your warning signal. You must recognize this fact and continue driving cautiously.
- Situations may occur that obstruct your warning signal when natural and man-made objects are between your vehicle and others, such as raising your hood or trunk lid. If these situations occur, be especially careful.
- All effective sirens and horns produce loud sounds that may cause, in certain situations, permanent hearing loss. You and your passengers should consider taking appropriate safety precautions, such as wearing hearing protection.

## ***Safety Messages to Operators***

---

- To be an effective warning device, this product produces bright light that can be hazardous to your eyesight when viewed at a close range. Do not stare directly into this lighting product at a close range, or permanent damage to your eyesight may occur.
- It is important that you fully understand how to safely operate this warning system before use.
- Operate your vehicle and its light/sound system in accordance with your department's Standard Operating Procedure.
- If a selected function does not perform properly or if any of the LEDs remain illuminated when the control is off, disconnect the power connector from the control unit and contact the nearest service center.
- At the start of your shift, ensure that the entire warning light system and the siren system are securely attached and operating properly.

Failure to follow all safety precautions and instructions may result in property damage, serious injury, or death.

**RETAIN AND REFER TO THESE MESSAGES**

## Overview of the Light Bar

The Navigator<sup>®</sup> light bar is a linear, high profile LED light bar that offers First Responders a unique choice of using stationary LED heads and LED rotators in one platform. Designed to fit the needs of multiple agencies, the Navigator's options and overall flexibility can be used on fire apparatus and command/fleet vehicles.

A Navigator light bar can be configured to have all stationary LED heads, all rotating heads, or a mix of both stationary LED heads with rotating heads. The Navigator light bar comes in multiple lengths from 10 inches to 87 inches for a consistent look across an entire fleet of vehicles. Dome color options include red, amber, blue and clear while bulkhead options can be black or clear. Mirrors are used with rotating heads to give the effect of multiple flashes from a single rotating source.

Along with flashing stationary and rotating heads, the Navigator can be configured with work lights, stop/tail/turn lights, and steady-burn heads. White Light enable, Flood, Front and Rear Light Cutoff are standard features. The Navigator light bar is designed to flash one of 28 or 30 patterns in each mode of operation. The Navigator can also be configured to meet NFPA, SAE, and California Title 13 requirements.

For the Navigator to respond to SignalMaster commands, the rear facing heads must be red/amber, blue amber, or amber. SignalMaster functionality is limited to Navigators that are 45, 53, or 60-inches long. Only the amber channels perform SignalMaster functions.

The Flood/Scene feature of the Navigator illuminates the area around the vehicle. The Flood/Scene commands/inputs steady-burn the corresponding white lights and turn off any other LED in the activated light head.

## Solaris LED Reflector Technology

Federal Signal's exclusive Solaris LED rotating reflectors (SLR) and QuadraFlare reflectors are engineered to significantly increase off-axis warning and maximize the LED light source to eliminate dark spots for true 360-degree light coverage.

## LED Rotating Lights

The LED rotating lights are designed to be individually controlled single color or two-color lights. The lights rotate 90 RPM or 120 RPM depending on the Navigator flash pattern. The pattern of the LED warning lights is controlled by the central control board inside the light bar. The lights are rotated by quiet, smooth, precise, and efficient positioning stepper motors that control the Solaris S2 reflectors. The stepper motors have a longer life than conventional DC motors. The lights change to white when White Light is enabled, flood forward when Flood is enabled and be cut off to the rear.

Mirrors inside the light bar give the rotating head the effect of multiple flashes. The default direction of rotation is clockwise. Counter-clockwise rotation is selectable by changing a setting on a DIP switch on the rotator PCB. In addition, each reflector enables two LEDs to shine upward for the aerial location of the vehicle.

## QuadraFlare LED Stationary Lights

The QuadraFlare LED stationary lights are designed to be single-color or two-color discreet, two-tier warning lights. The lights are flashed by a central control board inside the light bar. Light heads can be configured with large 6 by 4 heads mounted in the center of the light bar and smaller 7 by 3 and 4 by 3 heads mounted on the ends of the light bar. The central control board controls all flashing of the light heads.

## Control Options

The Navigator is completely wired at the factory and does not require any additional internal wiring. There are red and black 10 AWG power leads which supply power to the light bar. There are separate +12 Vdc activated control leads that initiate the functions of the light bar or Convergence Network cable. If the light bar is configured from the factory with stop/tail/turn lights, there is a separate cable for splicing into the vehicle harness.

## Mount Options

Hook Mount Kit: Z8653134

Permanent Mount Kit: Z8653134-01

Flat Surface Mount Kit\*: Z8653178-1, Z8653178-2, Z8653178-3

4-inch Riser Mount\*: Z806501522-2, Z806501522-4

Vehicle Specific Mounting Options: HKB-(model). Contact the factory for updated vehicle hook-mount options

\*Kit options depend on the length of the light bar.

**Table 1 Dimensions in inches (\*less mounting feet)**

Models	Length	Height*	Width
NVG10	10.00 in	4.43 in	12.36 in
NVG18	17.60 in	4.44 in	12.37 in
NVG25	24.80 in	4.44 in	12.37 in
NVG45	45.30 in	4.44 in	12.37 in
NVG53	52.50 in	4.44 in	12.37 in
NVG60	59.15 in	4.44 in	12.37 in
NVG73	73.00 in	4.44 in	12.37 in
NVG87	86.85 in	4.44 in	12.37 in

**Table 2 Light Specifications**

Light Source Options	LED (All Heads)
Current draw — LED Rotator	2.5 A per rotator
Current draw — 4 x 3 warning head	1.5 A maximum per head—Steady Burn
Current draw — 6 x 4 warning head	1.5 A maximum per head—Steady Burn
Current draw — 7 x 3 warning head	1.5 A maximum per head—Steady Burn
Operating Temperature	-40°F to 176°F (-40°C to 80°C)
Reflector Style	Offset, compound curve, vacuum metalized reflectors

## Preparing for the Light Bar Installation

Taking the preparatory steps in this section before mounting and wiring the light bar to a vehicle will help to ensure that your installation is fast, easy, and error free.

### Unpacking the Light Bar

**⚠ CAUTION**

**HEAVY OBJECT:** Use lifting aids and proper lifting techniques when removing or replacing this product. Failure to follow this warning may cause personal injury.

Carefully unpack the light bar assembly and any other products included in the shipment. Inspect them for damage that may have occurred during shipping. If a product has been damaged, do not install or operate it. Immediately file a claim with the carrier describing the damage.

Check all envelopes, shipping labels, and tags before removing or destroying them. If you are missing any parts, contact Customer Support at 1-800-264-3578, 7 a.m. to 5 p.m., Monday through Friday (CT).

### Programming the Light Bar

Although the Navigator light bar is configured and programmed at the factory, you may want to change the default flash patterns before you install the light bar.

### Flashing Modes

The number of flashing modes varies by bar length. You can select a flash pattern for each available mode from the light bar's internal library of flash patterns. For a list of patterns, refer to Table 3 and Table 4 starting on page 13.

The INTERSECTION flashing mode is available in light bars controlled through the Convergence Network. The INTERSECTION Mode is typically a high-activity pattern that attracts attention to the vehicle as it approaches an intersection. The INTERSECTION mode overrides any of the flashing modes.

**NOTE:** If a SignalMaster<sup>®</sup> function is activated, it overrides any flashing mode.

### Selecting Flash Patterns

**⚠ WARNING**

**LIGHT HAZARD:** To be an effective warning device, this product produces bright light that can be hazardous to your eyesight when viewed at a close range. Do not stare directly into this lighting product at a close range, or permanent damage to your eyesight may occur.

To supply power to the light bar, use a fully charged 12-volt automotive battery and follow these steps:

1. Place the light bar on a sturdy flat surface.
2. Connect the 10 AWG black wire to the negative battery (-GND) terminal.
3. Connect the 10 AWG red wire through a 40 A Maxi fuse to the positive battery (+BAT) terminal.

## Selecting Flash Patterns

---

4. There are two methods of selecting a flash pattern in the Navigator depending on the cabling of the light bar:
  - Apply +12 Vdc to the orange lead on certain models of discrete-wire light bars.
  - Press the white button on the control board in the light bar. The button is located next to the connector for the power leads. This method is available in all Navigator light bars with a central control board.

### Selecting a Flash Pattern with the Orange Lead in the Control Cable

On light bars with a 10- or 20-conductor control cable, the orange lead is the pattern selection wire. Momentarily applying +12 Vdc to the orange lead advances the displayed pattern to the next one.

### Selecting a Flash Pattern with the Button

**NOTICE**

**STATIC-SENSITIVE DEVICE: The light bar circuitry can be damaged by electrostatic discharge (ESD). Follow anti-static procedures while installing the light bar.**

See Figure 1. The pattern selection button is located on the control board inside the light bar near the connector for the power leads. For instructions on removing the domes to access the button, see "Replacing a Dome or Bulkhead" on page 30.

With a flashing mode active, momentarily pressing the button advances the pattern to the next one.

**Figure 1 Flash pattern button on control board discrete-wired Navigator**

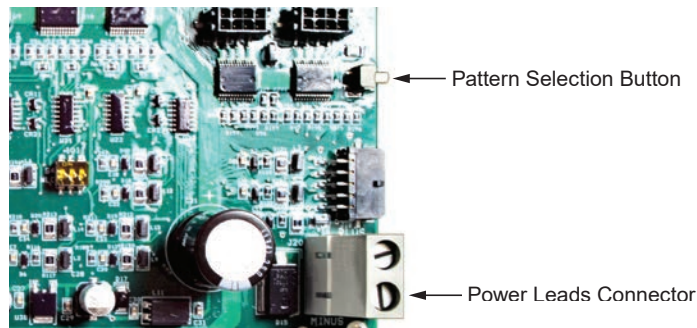

\*Channel A rotors are located in the outer positions of the light bar. Channel B rotators are located in the inner positions.

<sup>1</sup>Denotes default flash pattern for Mode 1.

<sup>2</sup>Denotes default flash pattern for Mode 2.

**Table 3 Navigator flash patterns: 10-conductor discrete-wired cable**

No.	Description	Rotators Channel A*	Rotators Channel B*
1 <sup>1</sup>	Solid-head alternating quad flashes	90 RPM	90 RPM
2 <sup>2</sup>	Split-head shuffle/triple flash	90 RPM	90 RPM
3	Rotate heads clockwise around	90 RPM	90 RPM
4	Top-bottom alternate flash	120 RPM	90 RPM
5	Criss-cross shuffle followed by a solid flash – 53 cycles per minute	120 RPM	90 RPM
6	Split alternate single flash – 120 FPM	120 RPM	90 RPM
7	Split alternate single flash – variable rate	120 RPM	90 RPM
8	Solid heads alternating 120 FPM	120 RPM	90 RPM
9	Split alternate single flash 75 FPM	90 RPM	90 RPM
10	FedPulse 75 – Solid Heads – Alternating 75 QFPM	90 RPM	90 RPM
11	Split head alternating quad flashes – 75 QFPM	120 RPM	90 RPM
12	Solid-head 120 triple FPM	120 RPM	120 RPM
13	Split-head 120 triple FPM	120 RPM	90 RPM
14	Solid head/split head alternating quad flashes	90 RPM	90 RPM
15	Solid head/split head quad flashes	120 RPM	90 RPM
16	Solid quad pulse/solid all on	120 RPM	90 RPM
17	Bottom top shuffle-solid pulse	120 RPM	90 RPM
18	FedPulse 75 followed by 120 triple flash	90 RPM	90 RPM
19	Bottom top shuffle – 75 single FPM	90 RPM	90 RPM
20	Split head shuffle – 75 single FPM	90 RPM	90 RPM
21	Bottom top shuffle – criss-cross shuffle – 75 patterns per minute	90 RPM	90 RPM
22	Top/bottom alternate single flash – variable rate	120 RPM	90 RPM
23	Split alternate – top/bottom alternate single flash	120 RPM	90 RPM
24	FedPulse 75 – split heads –alternating – 75 QFM	90 RPM	90 RPM
25	Split head shuffle/triple flash/alternating shuffle	90 RPM	90 RPM
26	Triple solid head flashes/alternating flash	90 RPM	90 RPM
27	Triple solid head flashes/alternating triple flash	90 RPM	90 RPM
28	Fast bottom top shuffle – criss-cross shuffle	90 RPM	120 RPM
29	FedPulse 75 – solid heads – split heads	90 RPM	90 RPM
30	Random pattern	--	--

## Selecting Flash Patterns

**Table 4 Navigator flash patterns: 45 in, 53 in, and 60 in serial-controlled/discrete light bar**

No.	Description	Rotator
1	Solid head alternating quad flashes	90 RPM
2	Split-head shuffle/triple flash	90 RPM
3	Rotate heads clockwise around	90 RPM
4	Alternating solid-head quad flash – amber	90 RPM
5	Decelerating solid-head flash – amber	90 RPM
6	Seven-head solid-head flash – amber	90 RPM
7	Quad -flash fast and solid-head flash – amber	90 RPM
8	Double-flash and quad flash solid-head flash – amber	90 RPM
9	Single-flash alternating solid head flash – amber	90 RPM
10	Quad-flash alternating solid head flash – amber	90 RPM
11	Split head alternating quad flashes – 75 QFPM	90 RPM
12	Alternating triple solid-head flash – amber	90 RPM
13	Single-flash all solid head flash – amber	90 RPM
14	Double-flash all solid head flash – amber	90 RPM
15	SCDOT double-flash all solid head flash – amber	90 RPM
16	Alternating sides flashing – police	90 RPM
17	2 quadrant chase – police	90 RPM
18	Alternate-end crisscross – police	90 RPM
19	Double criss cross, double half flash	90 RPM
20	Alternate side-split flash – police	90 RPM
21	Double-flash wig wag – police	90 RPM
22	Alternating solid-head quad flash and rotate – police	90 RPM
23	Variable flash left-right – police	90 RPM
24	Scroll center-out – police	90 RPM
25	Split-side wigwag and alternate-end criss cross flash – police	90 RPM
26	Alternate sides flashing and split-side wigwag	90 RPM
27	Amber random patterns	90 RPM
28	Police random patterns	90 RPM

## Changing the Features on a 45-inch, 53-inch and 60-inch Navigator

The central control board of the 45-inch, 53-inch, and 60-inch light bars have factory-set DIP switches that affect the operation of the light bar. SW2 and SW3 are nine-position switches numbered 1 to 18. These switches determine if the corresponding stationary light heads respond to functions and commands that use white light. If the corresponding light head has white LEDs, the switch is turned on (up), the light head flashes white when WHITE ENABLE is activated or responds to the FLOOD, TAKEDOWN, or ALLEY.

The third DIP switch (SW4) affects additional features, which are described in Table 5. The switches are set at the factory based on the configuration of the light bar.

**Figure 2 Central control board with switches off (down)**

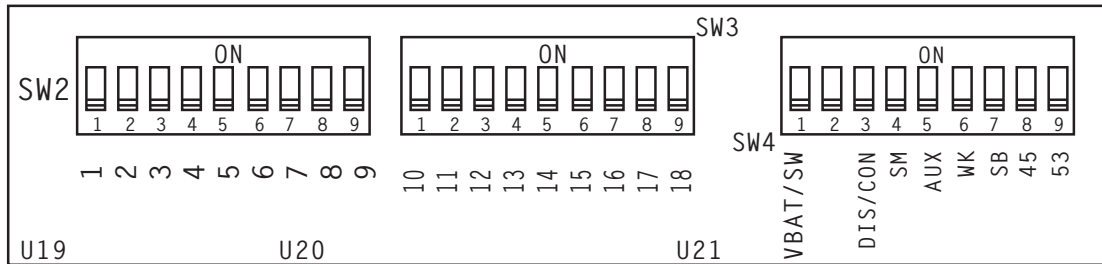

**Table 5 Functions of SW4**

VBAT/SW	If the Navigator light bar is controlled by a Convergence Network control head, the light bar can power the control head through the CAT5 cable. To enable this feature set the switch to ON.
DIS/CON	If the Navigator light bar is controlled by a Convergence Network control head, the light bar can power the control head. Turn on this feature by setting the switch to ON.
FL SM	The rear facing amber light heads do not flash in Modes 1, 2, 3 and only respond to SignalMaster commands. To enable flashing, set the switch to ON.
AUX	No function
WK	If the light bar is configured with work lights, the switch is set to ON.
SB	If the light bar is configured with steady burn lights on the passenger and driver side, the switch is set to ON.
45	This switch is set to ON for 45-inch light bars.
53	This switch is set to ON for 53-inch light bars.

## Changing the Rotator Functions in an All-Rotator Navigator

**NOTICE**

**STATIC SENSITIVE DEVICE:** This circuitry of the light bar can be damaged by electrostatic discharge (ESD). Follow anti-static procedures while changing the rotator functions.

An all-rotator Navigator has a power distribution board instead of a control board. The board accepts up to seven rotators. Each rotator has a 2 by 4 header on the board. Two positions on the header determine the operation of the rotator when power is applied. Two additional positions on the header determine if the rotator is to operate in Flood Mode, which is white light to the front or rear of the light bar. You can select how a rotator operates by placing a jumper across a pair of pins. See Figure 1 on page 12.

Figure 3 All-rotator power distribution board

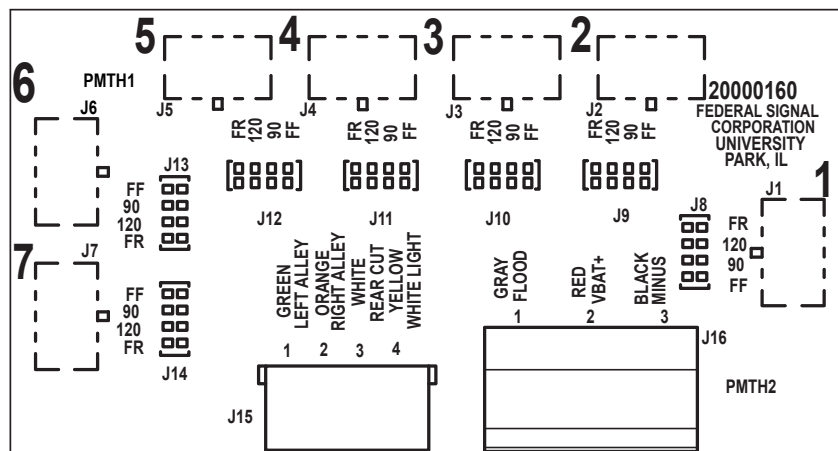

J15 CONNECTOR:  
ALLEY LIGHTS  
REAR LIGHT CUTOFF  
WHITE LIGHT

J16 CONNECTOR:  
+12 Vdc POWER  
FLOOD LIGHTS

- LEGENDS FOR LIGHTHEAD JUMPERS J8 TO J14**
- 120 = ROTATE AT 120 RPM
  - 90 = ROTATE AT 90 RPM
  - FF = FLOOD FORWARD (FACTORY CONFIGURED)
  - FR = FLOOD REARWARD (FACTORY CONFIGURED)

The selectable options are:

### Rotation speed

When power is applied to the light bar, the rotator lights rotate at either 90 RPM or 120 RPM. These functions are fixed while power is supplied to the light bar. To select a rotation angle, move the jumper on the power distribution board across the pairs of pins labeled 90 or 120.

### White light flood

When +12 Vdc is applied to the gray flood wire in the light bar, the rotator stops and the reflector faces either forward or rearward with the LEDs changing to white. The determination and configuration of whether a rotator should flood is made at the factory when the light bar is assembled. For a rotator to flood when the flood wire is activated, the jumper must be placed in the FF (Flood Forward) or FR (Flood Rearward) position on the power distribution board.

## Determining the Mounting Location and Wire Routing

### **⚠ WARNING**

**LOCATING OPERATOR CONTROLS:** *The controls for the light system must be located so that the VEHICLE and CONTROLS can be operated safely under all driving conditions.*

### **⚠ WARNING**

**AIRBAG DEPLOYMENT:** *Do not install equipment or route wiring in the deployment path of an airbag. Failure to observe this warning will reduce the effectiveness of the airbag or potentially dislodge the equipment, causing serious injury or death.*

### **⚠ WARNING**

**SEAT REMOVAL PRECAUTION:** *If a vehicle seat is temporarily removed, verify with the vehicle manufacturer if the seat needs to be recalibrated for proper airbag deployment. Failure to follow this warning cause serious injury or death.*

### **⚠ WARNING**

**INSTALLATION PRECAUTION:** *Do not mount a radio antenna within 18 inches of the lighting system. Placing the antenna too close to the lighting system could cause the lighting system to malfunction or be damaged by strong radio fields. Mounting the antenna too close to the lighting system may also cause the radio noise emitted from the lighting system to interfere with the reception of the radio transmitter and reduce radio reception. DO NOT drill holes in the light bar or install auxiliary devices on the light bar or the warning system may fail.*

### **⚠ WARNING**

**DRILLING PRECAUTIONS:** *Before drilling holes, check the area into which you plan to drill to ensure that you do not damage vehicle components. All drilled holes should be de-burred and all sharp edges should be smoothed. Additionally, all exterior drilled holes must be sealed with Motorcraft seam sealer T-A-2-B or equivalent to prevent the potential exposure to carbon monoxide or other potentially harmful fumes. Failure to observe this warning could cause serious injury or death.*

To prepare for installing the Navigator:

1. Ensure that the battery voltage is the same as the voltage rating of the light bar.
2. Verify that the light bar and mounting hardware fit the vehicle.
3. Determine where to mount the light bar on the vehicle.
4. Decide where to route wiring around airbag areas.
5. Decide where to route the power and ground wires from the light bar.

## Wiring the Navigator in the Vehicle

---

6. To make wiring easier, remove the seats and spare tire, and pull down the headliner where needed.
7. Separate all electronic equipment wiring from two-way radio equipment wiring.
8. To avoid interference, keep two-way radio antennas a minimum of 18 inches (45.7 cm) away from warning equipment.
9. Whenever possible, run full wire lengths. DO NOT splice the wires.
10. Do not coil excess wire. Leave a drain loop for servicing the light bar.
11. After drilling holes for wires, deburr them, smooth sharp edges, and insert grommets to protect the wires from chafing.
12. When you frame-ground the equipment, use the manufacturer-supplied ground locations in the vehicle.

**IMPORTANT:** After the installation, frequently inspect the light bar and mounting feet to ensure that all fasteners and brackets are tight.

## Wiring the Navigator in the Vehicle

Before wiring the Navigator in the vehicle, ensure that the light bar has been installed on the vehicle roof in accordance with the instructions included with the mounting kit. Installation of options such as an Opticom® require additional wiring to the warning light system and vehicle battery not covered in this manual. Review the electrical requirements of the light bar and use an installer-supplied switch or relay properly rated for the connection between the red power lead of the light bar and the fused power source. If additional wire length is needed, splice wire of the same gauge or heavier to the leads.

All of the light bar controls are integrated into the Navigator central control board. The Navigator has one of five different wiring types depending on its length and how it was configured. Table 6 shows on the wiring/cabling for each length/configuration of Navigator.

Refer to the page number listed for details on the proper wiring of your particular Navigator.

**Table 6 Cabling based on light bar length and configuration (see pages referenced)**

	10 inch		18 inch		25 inch	45 inch	
	Stationary/ Mixed	Rotator	Stationary/ Mixed	Rotator	Stationary/ Mixed	Stationary/ Mixed	Rotator
4-Conductor Cable	page 20	page 21		page 21			
Power, Ground, and 10-Conductor Cable			page 22		page 22		
Power, Ground, and 20-Conductor Cable						page 23	
Power, Ground, and Serial Cable						page 26	
Power, Ground, and 5 Control Leads	page 18						page 21

	53 inch		60 inch		73 inch		87 inch	
	Stationary/ Mixed	Rotator	Stationary/ Mixed	Rotator	Stationary/ Mixed	Rotator	Stationary/ Mixed	Rotator
4-Conductor Cable								
Power, Ground, and 10-Conductor Cable					page 22		page 22	
Power, Ground, and 20-Conductor Cable	page 23		page 22					
Power, Ground, and Serial Cable	page 26		page 26					
Power, Ground, and 5 Control Leads		page 21		page 21		page 21		page 21

## Connecting Power to the Light Bar

**⚠ WARNING**

**BATTERY EXPLOSION:** To avoid a battery explosion, always disconnect the negative cable first and reconnect it last. Avoid causing a spark when connecting near or to the battery. The gases produced by a battery can cause an electrical explosion that could result in vehicle damage and serious injury.

**⚠ WARNING**

**PROPER GROUNDING:** The light bar **WILL NOT** light up or flash if it is improperly grounded. Be sure that the light bar is connected to a good vehicle ground. Failure to observe this warning can lead to equipment failure and may result in serious injury or death.

**⚠ WARNING**

**SPARK HAZARD:** If wires are shorted to the vehicle frame or each other, high-current conductors can cause hazardous sparks resulting in electrical fires and molten metal. Verify that no short circuits exist before connecting to the positive (+) battery terminal.

**⚠ WARNING**

**CURRENT CAPABILITY:** For safe operation of the light bar, the power control switch and wiring must be capable of handling the rated current of the fuse at the source.

### 10-inch All-Stationary Navigator with a 4-Conductor Control Cable

The 10-inch all stationary Navigator has a 4-conductor cable exiting the light bar. Each wire has the following function:

- Black Wire: Attach this wire to a known good vehicle ground.
- Mode 1: Applying +12 Vdc to the red wire activates flashing mode. This wire must be on a switched feed that is fused at 10 A.
- White Light: Applying + 12 Vdc to the white wire while the light bar is flashing activates the white LEDs in the light heads, if installed (White Light Enable). If used, this wire must be on a switched feed that is fused at 10 A.
- Work Light: Apply + Vdc to the green wire activates flashing.

**Figure 4 Wire functions for 4-conductor cable (10-inch all stationary)**

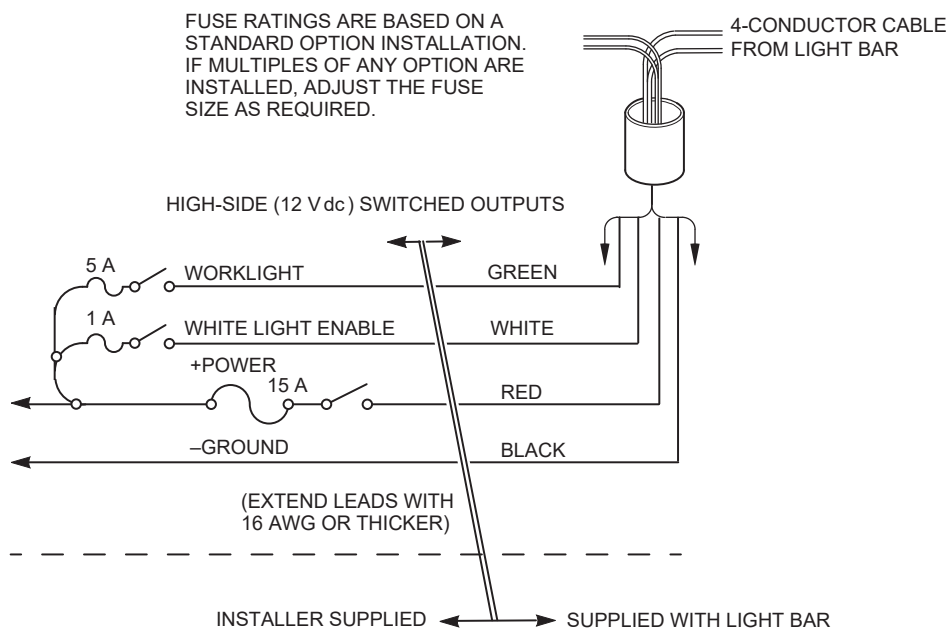

### 10-inch or 18-inch All-Rotator Navigator with a 4-Conductor Control Cable

A 10-inch or 18-inch all-rotator Navigator has a 4-conductor cable exiting the light bar. Each wire has the following function:

- Black Wire: Attach this wire to a known good vehicle ground.
- 90 RPM: Applying +12 Vdc to the red wire turns on the rotators, which spin at 90 RPM. This wire must be on a switched feed that is fused at 10 A.
- White Light: Applying + 12 Vdc to the white wire while the while the rotators are active activates the white in the rotators configured with white light. The rotator LEDs are white to the front and a primary color to the rear. If used, this wire must be on a switched feed that is fused at 10 A.
- 120 RPM: Applying +12 Vdc to the green wire turns on the rotators, which spin at 120 RPM. This wire must be on a switched feed that is fused at 10 A.

### Navigator with Power, Ground, and 5 Control Leads

Navigators with this wiring have 10 AWG red and black power leads along with white, yellow, green, and orange leads.

- Black Wire: Attach this wire to a known good vehicle ground.
- 90 RPM: Applying +12 Vdc to the red lead activates the rotators.
- White Light: Applying +12 Vdc to the yellow lead powers the white light in the rotators configured for white light. The rotator LEDs are white to the front and red to rear. This wire must be on a switched feed.
- Flood: Applying +12 Vdc to the gray lead enables White Light Flood in the rotators configured for Flood. The light heads flood forward or rearward depending on the jumper setting on the power distribution board. See Figure 3 on page 16.

## Connecting Power to the Light Bar

- Rear Light Cutoff: Applying +12 Vdc to the white lead enables rear light cutoff in the rotators.
- Driver-Side Alley: Applying +12 Vdc to the green lead powers the driver-side alley light.
- Passenger-Side Alley: Applying +12 Vdc to the orange lead powers the passenger-side alley light.

### Navigator with Power Ground and 10-Conductor Control Cable

A Navigator with full-function control has red and black 10 AWG power leads. There is a separate 10-conductor control cable, the functions of which are defined in Figure 5 below and in Table 7. All inputs are high-side activated, which means that applying +12 Vdc activates the input. For instructions on wiring lights configured as stop/tail/turn, see page 27.

- Black Power Lead: Attach this lead to a known good vehicle ground.
- Red Power Lead: Attach this lead to a known good vehicle ground.

**Figure 5 Wire functions for 10-conductor cable**

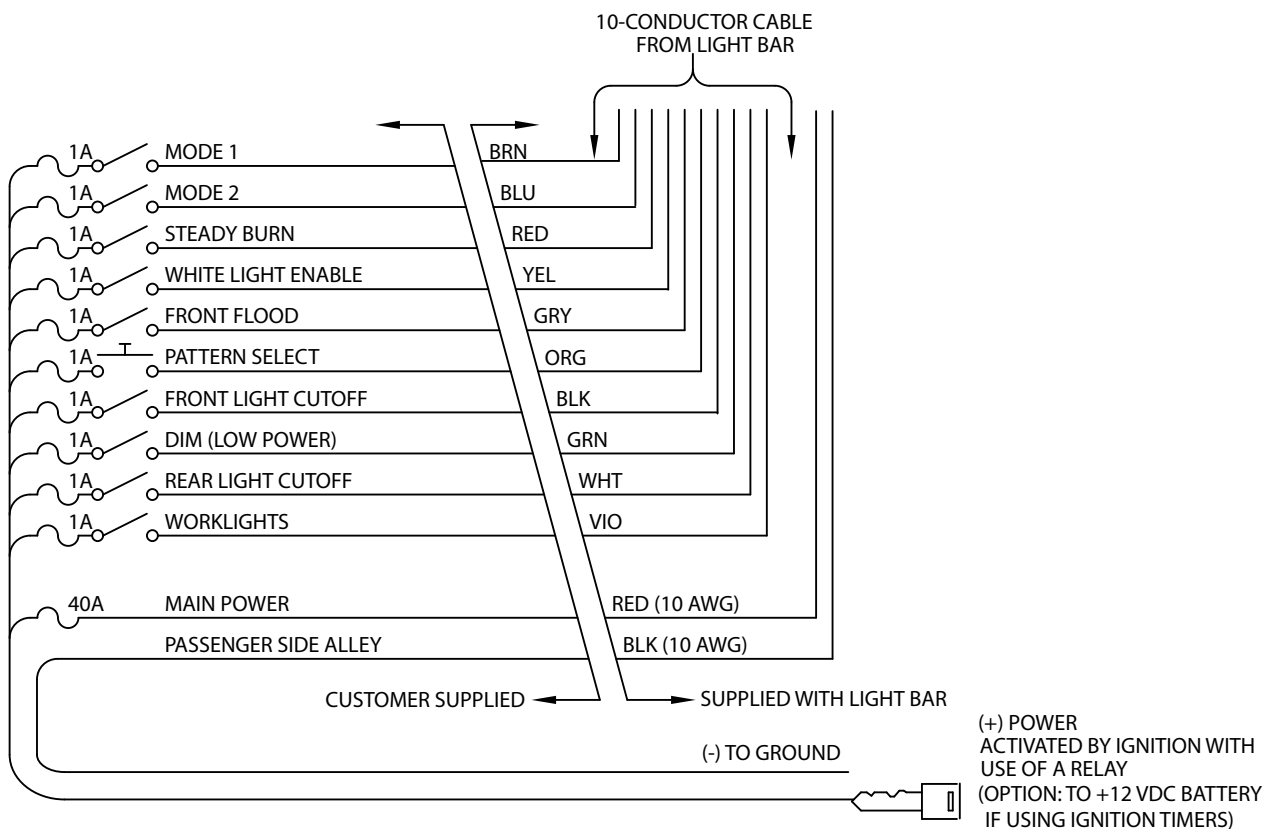

**Table 7 Light bar functions for 10-conductor cable**

<b>Wires</b>	<b>Function</b>	<b>Description</b>
Brown	Mode 1	Applying +12 Vdc activates the light bar in Mode 1 (Primary Mode) has priority over Mode 2 (Secondary Mode). The light bar can be programmed to have one of 30 flash patterns in this mode.
Blue	Mode 2	Applying +12 Vdc activates the light bar in Secondary Mode. The light bar can be programmed to have one of 30 flash patterns in this mode.
Red	Steady Burn Red	Applying +12 Vdc activates any steady burn modules in the light bar. The light bar is configured upon request for this option.
Yellow	White Light Enable	When calling for the right of way, a vehicle responding to an emergency is permitted to have white light. Applying +12 Vdc activates the white flashing LED heads and may turn the rotators white depending on the light bar configuration.
Gray	Flood Mode	Applying +12 Vdc activates Flood Mode, which turns on lights that are configured for Steady White.
Orange	Pattern Selection	Touching the wire to +12 Vdc changes the pattern and stores it in memory.
Black	Front Light Cutoff	Applying +12 Vdc cuts off forward flashing lights.
Green	Dim	Applying +12 Vdc dims the light bar 50 percent. Dimming has no effect on the rotating light heads.
White	Rear Light Cutoff	Applying +12 Vdc cuts off light to the rear.
Violet	Work lights	Applying +12 Vdc activates the work lights if configured for this option when the light bar is ordered.

### **Navigator with a 20-Conductor Control Cable**

A Navigator with full-function control has red and black 10 AWG power leads. There is a separate 20-conductor control cable, the functions of which are defined in Figure 6 below and in Table 8 on page 25. All inputs are high-side activated, which means that applying +12 Vdc activates the input. For instructions on wiring lights configured as stop/tail/turn, see page 27.

- Black Power Lead: Attach this lead to a known good vehicle ground.
- Red Power Lead: Attach this lead to a known good vehicle ground.

# Connecting Power to the Light Bar

Figure 6 Light bar functions for 20-conductor cable

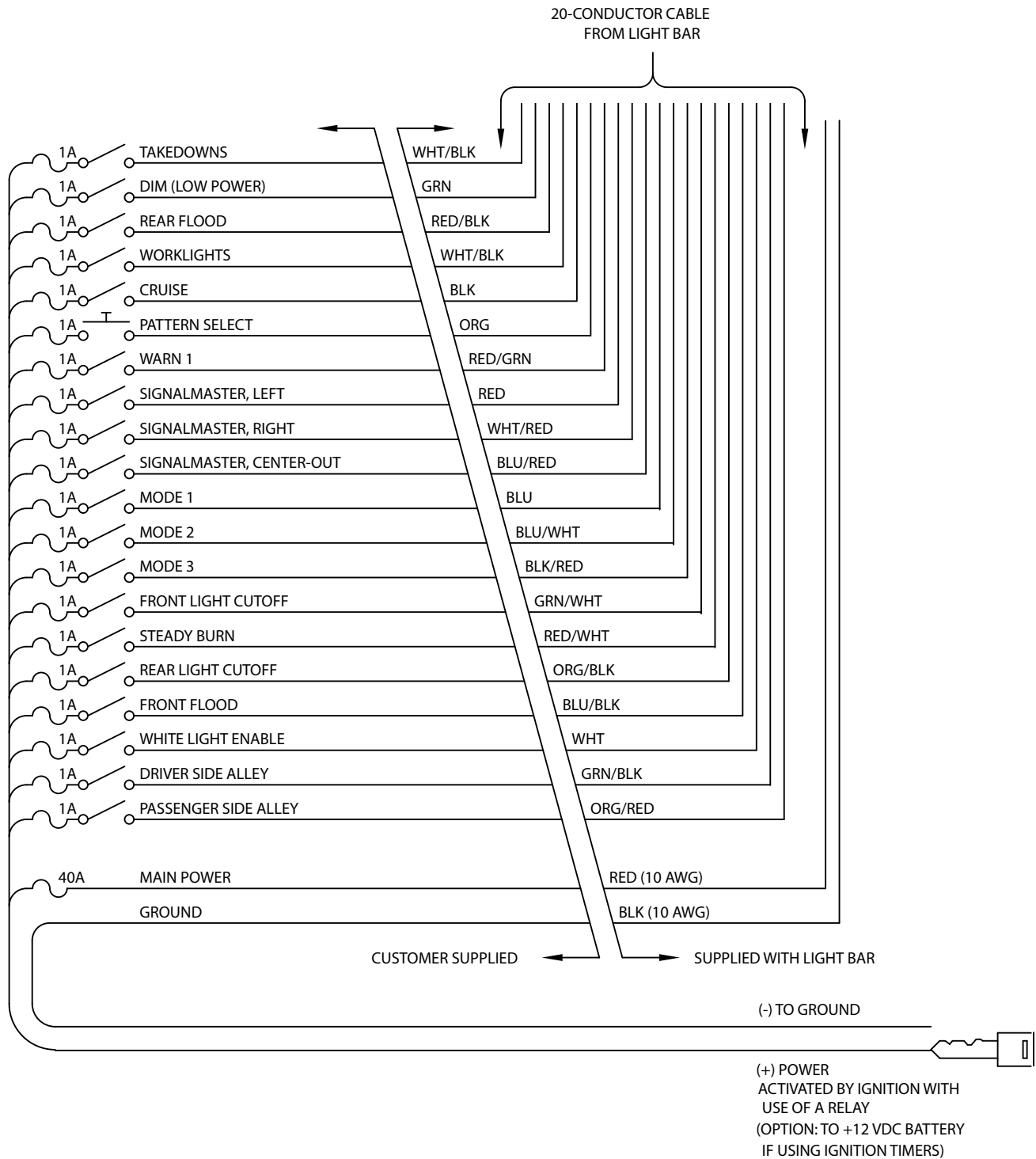

**Table 8 Light bar functions for 20-conductor cable**

<b>Wires</b>	<b>Function</b>	<b>Description</b>
White/ Black	Takedown	Applying +12 Vdc provides white Steady Burn light to the front. Overrides Front Light Cutoff.
Green	Dim	Applying +12 Vdc dims the light bar 50 percent. Dimming does not affect on the rotating heads.
Red/ Black	Rear Flood	Applying +12 Vdc activates lights that have white to the rear in Flood Mode.
Black/ White	Work lights	Applying +12 Vdc activates the work lights if configured for this option when the light bar is ordered.
Black	Cruise	Applying +12 Vdc activates the Cruise Mode of the light bar.
Orange	Pattern Change	Touching the wire to +12 Vdc changes the pattern and stores it in memory.
Red/ Green	Warn 1	Applying +12 Vdc activates the SignalMaster heads in the Warn 1 pattern. This option is only available if the light bar is configured for this SignalMaster when the light bar is ordered.
Red	SignalMaster Left	Applying +12 Vdc activates the left SignalMaster pattern. The option is only available if the light bar is ordered with a SignalMaster configured at the factory. Left is the input with the lowest SignalMaster priority.
White/ Red	SignalMaster Right	Applying +12 Vdc activates the Right SignalMaster pattern. The option is only available if the light bar is ordered with a SignalMaster configured at the factory. Right has priority over Left.
Blue/ Red	SignalMaster Center	Applying +12 Vdc activates the Center SignalMaster pattern. The option is only available if the light bar is ordered with a SignalMaster configured at the factory. Center has priority over Left and Right.
Blue	Mode 1	Applying +12 Vdc activates the light bar in Mode 1. The light bar can be programmed to have one of 28 flash patterns in this mode. Mode 1 is the lowest priority.
Blue/ White	Mode 2	Applying +12 Vdc activates the light bar in Mode 2. The light bar can be programmed to have one of 28 flash patterns in this mode. Mode 2 overrides Mode 1.
Black/ Red	Mode 3	Applying +12 Vdc activates the light bar in Mode 3. The light bar can be programmed to have one of 28 flash patterns in this mode. Mode 3 is the highest priority and overrides Modes 2 and 1.
Green/ White	Front Light Cutoff	Applying +12 Vdc cuts off light to the front.
Red/ White	Steady Burn	Applying +12 Vdc activates in the front light heads in Steady Burn Mode
Orange/ Black	Rear Light Cutoff	Applying +12 Vdc cuts off light to the rear.
Blue/ Black	Front Flood	Applying +12 Vdc activates lights that have white to the front in flood mode.
White	White Light Enable	When calling for the right of way, a vehicle responding to an emergency is permitted to have white light. Applying +12 Vdc activates the white flashing LED heads and may turn the rotators white depending on the light bar configuration.
Green/ Black	Driver Side Alley	Applying +12 Vdc activates the Driver Side Alley light if configured for this option when the light bar is ordered.
Orange/ Red	Passenger Side Alley	Applying +12 Vdc activates the Passenger Side Alley light if configured for this option when the light bar is ordered.

### Navigator with Power, Ground Leads, and Serial Cable

A Navigator light bar controlled by a Federal Signal Convergence Network device has 10 AWG red and black power leads and a Convergence Network Serial Communication Cable (CAT5). A Federal Signal SmartSiren® Control Head, 6-Button Controller, or 3-Button Controller are devices that can be used to directly control the light bar.

- Black Power Lead: Attach this lead to a known good vehicle ground.
- Red Power Lead: Attach this lead to the positive battery terminal through a 40 A Maxi fuse.
- CAT5 Cable: Route and connect this cable to a Convergence Network controller.

**Table 9 Light bar functions for 10-inch Navigator cable**

Wires	Function	Description
Green	Work light	Applying +12 Vdc to the green wire turns on the work light.
White	White Light Enable	When calling for the right of way, a vehicle responding to an emergency is permitted to have white light. Applying +12 Vdc activates the white flashing LED heads and may turn the rotators white depending on the light bar configuration.
Red	+ Power	Supplies power to the light bar and initiates flashing.
Black	- Ground	

#### White Light Enable

To enable white light, connect the +12 Vdc white lead.

If the Navigator is ordered with a work light in one of the positions, applying +12 Vdc to the green wire turns on the work light.

#### Control Heads

The light bar can have the following features controlled through control heads such as a Federal Signal SmartSiren keypad or 6-Button controller. Individual flash patterns are activated when the slide switch placed in Mode 1, Mode 2, or Mode 3. When the pattern is flashing white light can be enabled. Left and Right Alley lights can also be activated.

#### Rear SignalMaster/Warn Patterns and Work lights

A complete selection of SignalMaster and Warn patterns can be generated at the rear of the light bar if it is ordered from the factory with SignalMaster light heads. Two dedicated work light heads can also be controlled. The work lights, which are angled downward, do not flash a pattern.

#### Front/Rear Light Cutoff and Flood

Front- and rear-light cutoff in the light bar can be controlled as well as floodlight to the front, rear, driver side, and passenger side.

#### Takedown Lights

Takedown lights are available at fixed positions in the light bar.

**Dimming and Steady Burn Cruise**

The fixed-position LED heads can be dimmed during a flash pattern. In addition, the light bar can be operated in Steady-Burn Dim Cruise Mode. Rotating lights do not dim in either of these dimming modes.

**Steady Burn**

Steady burn of one or more light heads is also available as a factory-configured option.

**Wiring the Navigator Stop/Tail/Turn Lights Option**

Navigator light bars are configured per customer order at the factory for the stop/tail/turn feature. If you are installing the light bar in a vehicle that has turn signal lights separate from the brake lights, you must purchase a separately available tail light converter.

To wire the light bar the for stop/tail/turn feature:

1. Disconnect the vehicle battery.
2. Locate the red, black, and green wires in the 3-conductor cable.
3. Splice the appropriate cables into the vehicle wiring. The input leads require a positive (+) 12 Vdc signal to activate. See Figure 7.

**Figure 7 Cable leads for stop/tail/turn lights**

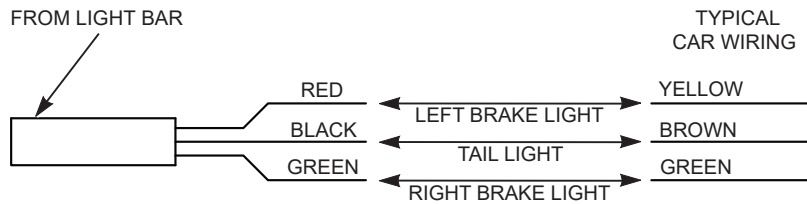

4. Apply power to the light bar.
5. Reconnect the vehicle battery.
6. Test the light bar. The stop/tail/turn functions of the light bar should coincide with the vehicle stop/tail/turn functions.

**Navigator Light Bars with TCL option**

When the TCL option is configured in the Navigator light bar, the heads will flash when the light bar is in a flashing mode and White Light Enable is active. The TCL light heads can flash in one of eight different patterns. Pattern selection is accomplished via a button on rear of the light head. See Table 10 for list of TCL flash patterns.

**Selecting a TCL flash pattern**

To supply power to the light bar, use a fully charged 12-volt automotive battery and follow these steps:

1. Place the light bar on a sturdy flat surface.
2. Remove domes and bulkheads as needed to obtain access to the rear of one of the TCL light heads. For instructions on removing the domes and bulkheads, see "Replacing a Dome or Bulkhead" on page 25.

3. Connect the 10 AWG black wire to the negative battery (-GND) terminal.
4. Connect the 10 AWG red wire through a 40 A Maxi fuse to the positive battery (+BAT) terminal.
5. Activate a flashing mode (Mode 1, 2 or 3) and White Light Enable.
6. With the bar flashing, momentarily press the push button. The flash pattern will momentarily be represented by the number of LEDs illuminated in the TCL light head.
7. Ensure that both TCL light heads show the same pattern number.
8. Repeat as needed to select the desired TCL flash pattern.
9. Allow TCL heads to flash for 5 seconds to ensure the flash pattern is stored in memory
10. Remove light bar from power and replace the domes and bulkheads.

**Table 10 TCL Flash Patterns**

Pattern	Description
1	Gamma Flash with Parsec Pulse
2	Gamma Flash
3	Lissajous 1 with Parsec Pulse
4	Lissajous 1
5	Lissajous 2 with Parsec Pulse
6	Lissajous 2
7	Fed Pulse 75
8	Fed Pulse 150
9	LED Test
10	Accelerometer Test

Patterns 9 and 10 are for diagnostic purposes. Pattern 9 illuminates each LED one at a time. Pattern 10 illuminates one LED based on the orientation of the light head.

## Maintaining and Servicing the Navigator

**⚠ WARNING**

**QUALIFICATIONS:** *To properly service a light assembly, you must have a good understanding of automotive electrical procedures and systems, along with proficiency in the installation and use of safety warning equipment.*

**⚠ WARNING**

**LIGHT HAZARD:** *To be an effective warning device, an emergency warning system produces bright light that can be hazardous to your eyesight when viewed at a close range. Do not stare directly into this lighting product at a close range, or permanent damage to your eyesight may occur.*

**⚠ CAUTION**

**HEAVY OBJECT:** *Use lifting aids and proper lifting techniques when removing or replacing this product. Failure to follow this warning may cause personal injury.*

**NOTICE**

**STATIC-SENSITIVE DEVICE:** *The circuitry of the light bar can be damaged by electrostatic discharge (ESD). Follow anti-static procedures while installing or servicing the light bar.*

Establishing a regular maintenance schedule for the Navigator extends the life of the light bar and ensures safety. Periodically check that the light bar operates properly and that all mounting hardware is securely fastened to the vehicle. Also, inspect the domes for cracks, crazing (hairline cracks), discoloration, and other defects.

The modular design of the Navigator makes it easy to remove components for replacement without disassembling them. A light head assembly, for example, which includes a PCB, insulator, reflector, and mounting bracket, can be disconnected and removed from the light bar as one piece. All electronic assemblies are secured to the aluminum extrusion with #10, Type B pan-head Torx screws

The positions of all components are set by the length and model of the light bar. Use the existing screw holes when replacing electronic assemblies. For list of replacement parts and ordering information, see the tables starting on page 34.

## Cleaning the Domes

To prolong the service life of the domes, periodically clean them using proper procedures and compatible cleaners.

**NOTICE**

**CRAZING/CLEANING SOLUTIONS:** *The use of cleaning solutions, such as strong detergents, solvents, and petroleum products, can cause crazing (cracking) of the light bar lens and reflectors. To clean the reflectors, use a soft, damp cloth. To clean the lens, use a soft cloth and a solution of water and a mild detergent.*

**⚠ WARNING**

**CRAZING/CHEMICALS:** *Crazed, cracked or faded lenses or reflectors reduce the light output and the effectiveness of the lighting system. A lens or reflectors showing this type of aging must be replaced. Failure to follow this warning may result in bodily injury or death.*

**NOTICE**

**EQUIPMENT DAMAGE:** *Do not use a pressure washer to clean the light bar. Failure to heed this notice will damage the light bar.*

To clean the domes:

1. Rinse the domes with lukewarm water to loosen dirt and debris.
2. Use a mild soap, lukewarm water, and a soft cloth to gently clean the plastic surfaces. To avoid damaging the domes, do not use heavy pressure or caustic, abrasive, or petroleum-based cleaners.

3. Rinse and dry the plastic surfaces with a soft cloth to prevent water spotting.

### **Cleaning the Reflectors and Mirrors**

After handling the reflectors and mirrors, ensure that they are free from dust and fingerprints. Dirty reflectors and mirrors can reduce the light output of the Navigator. Remove dust with compressed air. Use a lint-free cloth and rubbing alcohol to remove fingerprints. To avoid damaging the reflectors, do not use heavy pressure or caustic, abrasive, or petroleum-based cleaners.

### **Replacing a Dome or Bulkhead**

The light bar domes filter the LED lights and protect the circuitry, while the bulkheads lock the domes together. Bulkheads also form a water-tight seal with the rubber dome gaskets on the edges of the domes. If a dome or bulkhead is damaged, it must be replaced.

To remove one or more domes and bulkheads:

1. Disconnect all power from the light bar.
2. See page 9. Use a Phillips screwdriver to remove the two 1/4"-20 pan-head screws and the nameplate.
3. Steady the light bar while striking the sides of an end dome with your hand until you break the seal and loosen the dome.
4. Wiggle the dome free and slide it off the aluminum extrusion.
5. Remove domes and bulkheads as needed

**Figure 8 Navigator (25-inch) with the end dome disassembled**

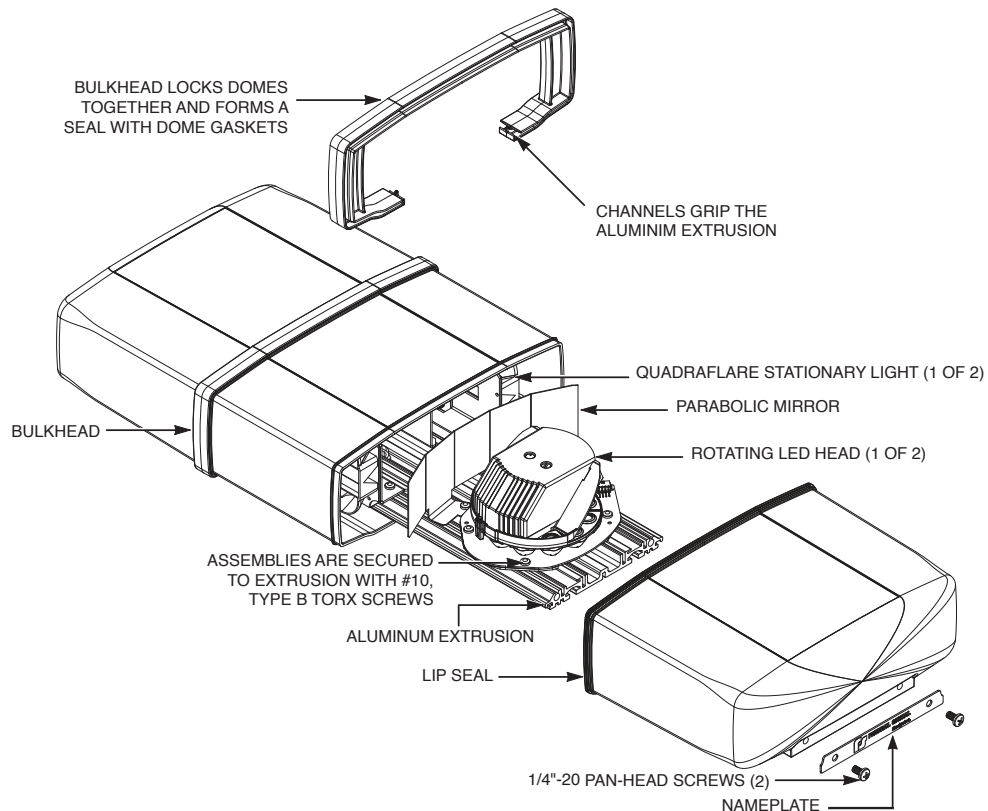

## Installing Domes and Bulkheads

To install a dome:

1. Ensure that a bulkhead is in place on the aluminum extrusion to accept the edge of the dome.
2. Slide the domes and bulkheads onto the aluminum extrusion. Ensure that the edge of each dome is fully seated in the bulkhead.
3. Strike the end of the end dome with your hand until it is fully seated in the bulkhead.
4. Secure the name plate to the end dome with the two 1/4 in x 20 pan-head screws.

## Replacing a Rotator Assembly

The rotator assembly comprises a reflector and circuitry that controls the flash pattern and the rotator stepper motor. If the rotator appears to seize or the light head is inoperative or operates incorrectly, check the fuses and connections between the light bar and the battery. Also check the cable connection between the rotator PCB and the controller or power distribution board.

To replace a rotator assembly:

1. Remove the dome as described in “Replacing a Dome or Bulkhead.”
2. Disconnect the 8-pin connector from the rotator PCB.
3. Remove the four #10 Type B Torx screws securing the PCB to the aluminum extrusion and remove the PCB.
4. Center the holes in the rotator PCB over the holes in the aluminum extrusion.
5. Insert and tighten the four Torx screws.
6. Test the light bar for proper operation.
7. Reinstall the dome(s).

**Figure 9 Navigator (25 inch) viewed from the top**

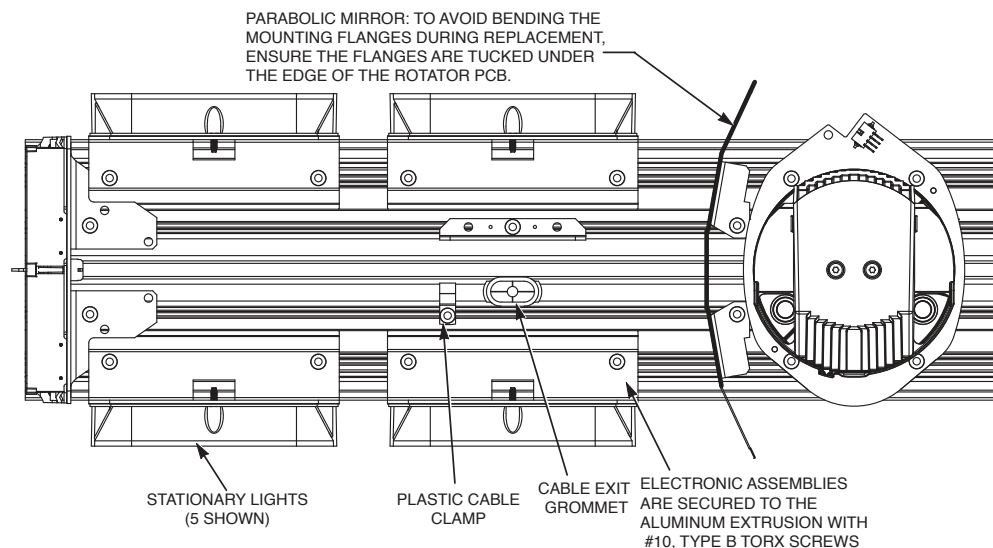

## Configuring How a Rotator Operates

If you replace a rotator, you may have to configure how it operates depending on its position in the light bar. A three-position DIP switch on the edge of the rotator PCB (Figure 10) enables you to select one of five settings for a standard pod.

Figure 10 Location of SW1 DIP switch for rotator operation

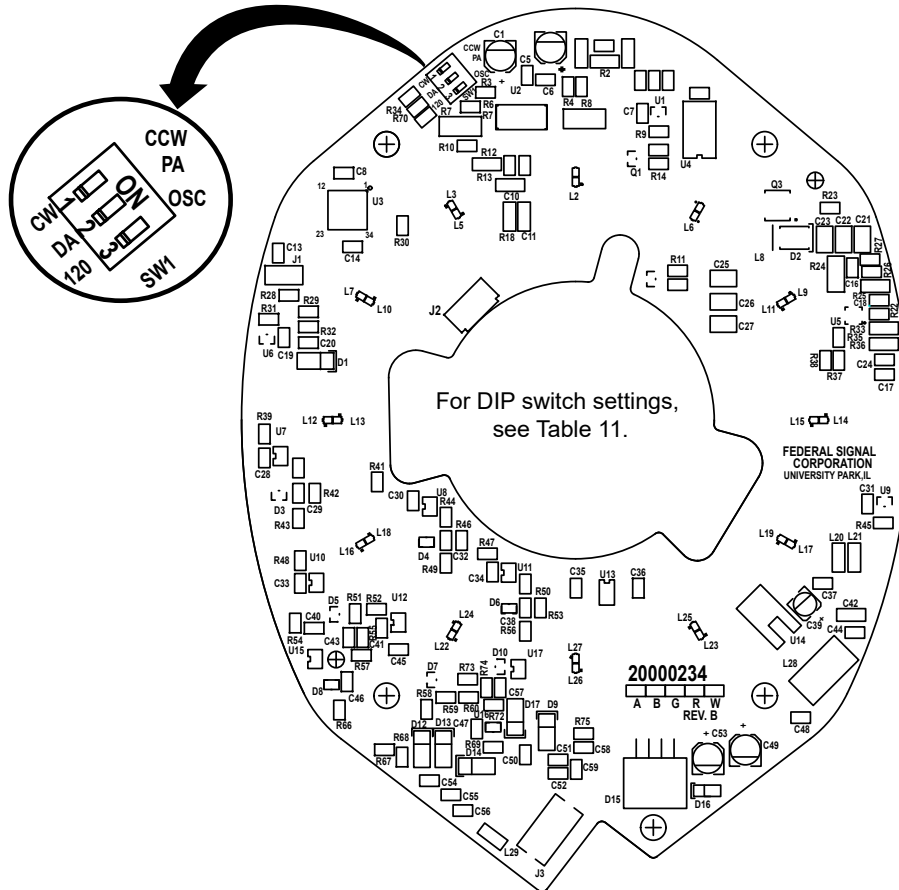

Table 11 DIP switch settings for rotator operation

SW1 DIP switch in the default off (down) position		
1	CW	Clockwise rotation
2	DA	Driver-side alley (pod faces the driver side)
3	120	Pod rotates at 120 RPM
SW1 DIP switch in the on (up) position		
1	CCW	Counter-clockwise rotation
2	PA	Passenger-side alley (pod faces the passenger side)
3	OSC	Pod oscillates to the front

## Replacing a Mirror

Scratched or bent mirrors may reduce the effectiveness of the lights.

To replace a mirror:

1. Remove the dome as described in "Replacing a Dome or Bulkhead" "Replacing a Dome or Bulkhead" on page 30.
2. Remove the #10, Type B Torx screws securing the mirror to the aluminum extrusion.
3. Remove the mirror.
4. Tuck the edges of the mounting flange of the new mirror under the edge of the rotator PCB.
5. Secure the mirror to the extrusion with the two #10 Torx screws
6. Reinstall the dome(s).

## Replacing a QuadraFlare Stationary Light

The light head assembly, which includes a PCB, insulator, reflector, and mounting bracket, is removable as one piece.

**NOTICE**

***DAMAGE TO THE WARNING LIGHTS: When installing QuadraFlare warning lights on a vehicle, you must use the manufacturer's mounting gasket, screws, and screw grommets. Do not use an impact drill or electric screw gun when installing the lights. Torque the mounting screws to the manufacturer's specification of 12 in lb +/- 10 percent. Failure to observe this notice will damage the lights and void any warranty claims for the lights.***

To replace a QuadraFlare:

1. Remove the dome as described in "Replacing a Dome or Bulkhead" on page 30.
2. Disconnect the connector at the light head PCB.
3. Remove the #10 Torx screws securing the light assembly to the aluminum extrusion. See Figure 8 on page 30.
4. Center the screws holes in the mounting base of the new light assembly over the holes in the aluminum extrusion.
5. Insert and tighten the #10 Torx screws
6. Reconnect the control cable.
7. Test the light bar for proper operation and reinstall the dome(s).

### Troubleshooting the Light Bar

This section provides troubleshooting assistance for common problems. If you have any questions left unanswered, call the Federal Signal Service Department at 1-800-433-9132, 7 a.m. to 5 p.m., Monday through Friday (CT).

**Table 12 Troubleshooting tips**

<b>Problem</b>	<b>Corrective Action</b>
Light bar does not light	<ul style="list-style-type: none"><li>• Check that the light bar's red power line (+BAT) and the black ground-power line (-GND) are properly connected to a good, fully charged 12-volt battery. Check the 40 A fuse.</li><li>• Ensure that the ground connection from the light bar controller to the aluminum extrusion is good.</li><li>• Check the fuses on the light bar controller.</li></ul>
LED module does not light	<ul style="list-style-type: none"><li>• Swap the LED head/bracket assembly with a good module to see if the board is bad.</li><li>• Check the connections of the cable that goes from the light bar controller to the LED ROC board.</li><li>• Ensure that Steady Burn switches on the light bar controller (SW3 PSR for the passenger side and SW3 DSR on the driver side) are set correctly.</li></ul>
Half of an LED module does not light	<ul style="list-style-type: none"><li>• Replace the LED head/bracket assembly.</li></ul>
The light bar turns off when the Flash Takedown/Alley lights turn on	<ul style="list-style-type: none"><li>• Ensure that the vehicle battery is fully charged.</li><li>• Check that the light bar's red power line (+BAT) and black ground-power line (-GND) are properly connected to a good, fully charged 12-volt battery.</li><li>• Check the red power line (+BAT) and the black ground-power line (-GND) connections in the light bar and vehicle.</li></ul>

## Replacement Parts

**Table 13 6 x 4 light heads for use with 6-conductor cable**

Description	Part Number
6 x 4 LED Head/Bracket Assembly, Amber	806500795-A
6 x 4 LED Head/Bracket Assembly, Amber/Blue	806500795-AB
6 x 4 LED Head/Bracket Assembly, White/Amber	806500795-AW
6 x 4 LED Head/Bracket Assembly, Blue	806500795-B
6 x 4 LED Head/Bracket Assembly, White/Blue	806500795-BW
6 x 4 LED Head/Bracket Assembly, Green	806500795-G
6 x 4 LED Head/Bracket Assembly, Red	806500795-R
6 x 4 LED Head/Bracket Assembly, Amber/Red	806500795-RA
6 x 4 LED Head/Bracket Assembly, Blue/Red	806500795-RB
6 x 4 LED Head/Bracket Assembly, White/Red	806500795-RW
6 x 4 LED Head/Bracket Assembly, White	806500795-W
6 x 4 LED Head/Bracket Assembly, Work Light	806500967

**Table 14 6 x 4 light heads for use with 8-conductor cable**

Description	Part Number
SM 6 x 4 LED Head/Bracket Assembly, Amber	806501335-A
SM 6 x 4 LED Head/Bracket Assembly, Amber/Blue	806501335-AB
SM 6 x 4 LED Head/Bracket Assembly, White/Amber	806501335-AW
SM 6 x 4 LED Head/Bracket Assembly, Blue	806501335-B
SM 6 x 4 LED Head/Bracket Assembly, White/Blue	806501335-BW
SM 6 x 4 LED Head/Bracket Assembly, Green	806501335-G
SM 6 x 4 LED Head/Bracket Assembly, Red	806501335-R
SM 6 x 4 LED Head/Bracket Assembly, Amber/Red	806501335-RA
SM 6 x 4 LED Head/Bracket Assembly, Blue/Red	806501335-RB
SM 6 x 4 LED Head/Bracket Assembly, White/Red	806501335-RW
SM 6 x 4 LED Head/Bracket Assembly, White	806501335-W
6 x 4 LED Head/Bracket Assembly, Work Light	806501335-WK

**Table 15 6 x 4 light heads for use with 10-conductor cable**

<b>Description</b>	<b>Part Number</b>
6 x 4 LED Head/Bracket Assembly, Amber/White	806501335-AAW
6 x 4 LED Head/Bracket Assembly, Amber (Front Facing)	806501335-AAX
6 x 4 LED Head/Bracket Assembly, Blue/Amber	806501335-BBA
6 x 4 LED Head/Bracket Assembly, Blue/White	806501335-BBW
6 x 4 LED Head/Bracket Assembly, Blue	806501335-BBX
6 x 4 LED Head/Bracket Assembly, Blue/White with Amber SM	806501335-BRA
6 x 4 LED Head/Bracket Assembly, Blue/Red with White	806501335-BRW
6 x 4 LED Head/Bracket Assembly, Red/Blue	806501335-RBX
6 x 4 LED Head/Bracket Assembly, Red/Amber	806501335-RRR
6 x 4 LED Head/Bracket Assembly, Red/White	806501335-RRW
6 x 4 LED Head/Bracket Assembly, Red	806501335-RRX
6 x 4 LED Head/Bracket Assembly, Amber (Rear Facing)	806501335-XXA

**Table 16 7 x 3 light heads for use with 6-conductor cable**

<b>Description</b>	<b>Part Number</b>
7 x 3 Head/Bracket Assembly, Amber	806501199-A
7 x 3 Head/Bracket Assembly, Amber/Blue	806501199-AB
7 x 3 Head/Bracket Assembly, White/Amber	806501199-WA
7 x 3 Head/Bracket Assembly, Blue	806501199-B
7 x 3 Head/Bracket Assembly, White/Blue	806501199-WB
7 x 3 Head/Bracket Assembly, Green	806501199-G
7 x 3 Head/Bracket Assembly, Red	806501199-R
7 x 3 Head/Bracket Assembly, Amber/Red	806501199-AR
7 x 3 Head/Bracket Assembly, Blue/Red	806501199-BR
7 x 3 Head/Bracket Assembly, White/Red	806501199-WR
7 x 3 Head/Bracket Assembly, White	806501199-W
7 x 3 Head/Bracket Assembly, Work Light	806501199-WK

**Table 17 4 x 3 light heads for use with 6-conductor cable**

Description	Part Number
Head/Bracket Assembly, Amber	806501313-A
Head/Bracket Assembly, Red/Green	806501313-RG
Head/Bracket Assembly, Amber/Blue	806501313-AB
Head/Bracket Assembly, White/Amber	806501313-AW
Head/Bracket Assembly, Blue	806501313-B
Head/Bracket Assembly, White/Blue	806501313-BW
Head/Bracket Assembly, Green	806501313-G
Head/Bracket Assembly, Red	806501313-R
Head/Bracket Assembly, Amber/Red	806501313-RA
Head/Bracket Assembly, Blue/Red	806501313-RB
Head/Bracket Assembly, White/Red	806501313-RW
Head/Bracket Assembly, White	806501313-W

**Table 18 LED rotators**

Description	Part Number
Amber Rotator Assembly	806501337-A
Amber/Blue Rotator Assembly	806501337-AB
Red/Amber Rotator Assembly	806501337-RA
Blue Rotator Assembly	806501337-B
Red/Blue Rotator Assembly	806501337-RB
Red Rotator Assembly	806501337-R
Green Rotator Assembly	806501337-G
White Rotator Assembly	806501337-W
Amber/White Rotator Assembly	806501337-AW
Blue/White Rotator Assembly	806501337-BW
Red/White Rotator Assembly	806501337-RW

**Table 19 Mirrors**

Description	Part Number
End Mirror	806501793
Rear Blocking Mirror (13.5" sections only)	806500832
Diamond Mirror (13.5" sections only)	806501791
Diamond Mirror (53" center section only, 2 required)	806501793
10" Navigator Mirror	806501487

**Table 20 Internal cables**

<b>Description</b>	<b>Part Number</b>
Cable, 6 Conductor, 12"	1751566-12
Cable, 6 Conductor, 25"	1751566-25
Cable, 6 Conductor, 35"	1751566-35
Cable, 6 Conductor, 45"	1751566-45
Cable, 6 Conductor, 60"	1751566-60
Cable, 6 Conductor, 80"	17500429-80
Cable, 8 Conductor, 12"	17500429-12
Cable, 8 Conductor, 25"	17500429-25
Cable, 8 Conductor, 35"	17500429-35
Cable, 8 Conductor, 45"	17500429-45
Cable, 8 Conductor, 60"	17500429-60
Cable, 8 Conductor, 80"	17500429-80
Cable, 10 Conductor, 25"	17501002-25

**Table 21 Internal light bar controllers and mini jumper**

<b>Description</b>	<b>Part Number</b>
Light Bar Controller, 8-LED Head, 2 Rotator	20000161
Light Bar Controller, 18-LED Head, 4 Rotator	20000102
Light Bar Controller, 7 Rotator	20000160
Light Bar Controller, 4-LED Head	20000205
Light Bar Controller, 18-LED Head, 3-Rotator	20000227
2-Position Mini Jumper	139A209

**Table 22 Bulkheads and domes**

<b>Description</b>	<b>Part Number</b>
Bulkhead, Black	806500526
Bulkhead, Clear	806500526-C
End Dome, Clear	806500523
End Dome, Red	806500523-R
End Dome, Amber	806500523-A
End Dome, Blue	806500523-B
Long Dome, Clear	806500524
Long Dome, Red	806500524-R
Long Dome, Amber	806500524-A
Long Dome, Blue	806500524-B
Short Dome, Clear	806500525
Short Dome, Red	806500525-R
Short Dome, Amber	806500525-A
Short Dome, Blue	806500525-B

**Table 23 End caps**

<b>Description</b>	<b>Part Number</b>
End Cap, 10" Light Bar, Clear	806500735
End Cap, 10" Light Bar, Red	806500735-R
End Cap, 10" Light Bar, Amber	806500735-A
End Cap, 10" Light Bar, Blue	806500735-B

## **Getting Technical Support and Service**

For technical support and service, please contact:

Service Department  
Federal Signal Corporation  
Phone: 1-800-433-9132  
Email: [empserviceinfo@fedsig.com](mailto:empserviceinfo@fedsig.com)  
[www.fedsig.com](http://www.fedsig.com)

## **Getting Repair Service**

The Federal Signal factory provides technical assistance with any problems that cannot be handled locally.

Any units returned to Federal Signal for service, inspection, or repair must be accompanied by a Return Material Authorization (RMA). Obtain a RMA from a local Distributor or Manufacturer's Representative.

Provide a brief explanation of the service requested, or the nature of the malfunction.

Address all communications and shipments to the following:

Federal Signal Corporation  
Service Department  
2645 Federal Signal Drive  
University Park, IL 60484-3167



**FEDERAL SIGNAL**  
Safety and Security Systems

2645 Federal Signal Drive  
University Park, Illinois 60484-3167

[www.fedsig.com](http://www.fedsig.com)

Customer Support

Police/Fire-EMS: 800-264-3578 • +1 708 534-3400

Work Truck: 800-824-0254 • +1 708 534-3400

Technical Support 800-433-9132 • +1 708 534-3400