

1000 SERIES - BACKUP ALARMS

SAFE-T-ALERT®

1000 SERIES

Specifications:

- Voltage: 12-24VDC or 12VDC
- Decibels: 85dB or 92dB
- Size: 2.25"w x 1.5"d x 2.94"h
- Average Amp Draw: .25AMP
- Polarity Protected: Yes
- Spike Protected (V): No
- Mounting: Vertical
- Warranty: 2 year
- Features:
 - Epoxy encapsulated circuit board
 - With wire leads

Certifications:

- CE



Variations:

PART #	DESCRIPTION
STA10302W	12-24VDC, 85dB
STA10400W	12VDC, 92dB

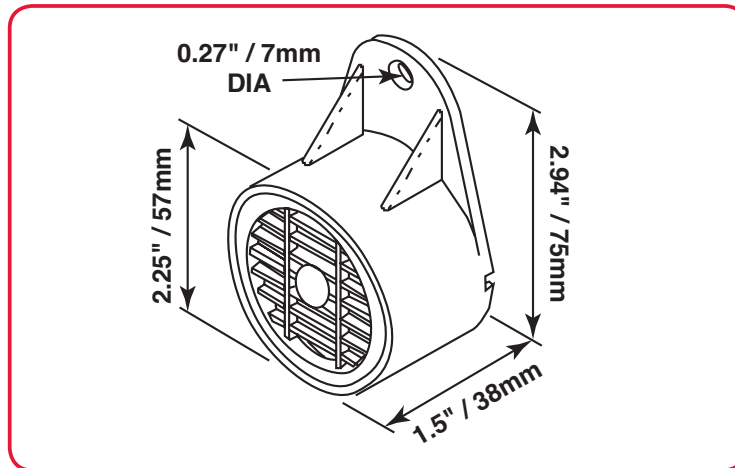

US: 16355 South Lone Elm Road • Olathe, KS 66062 • USA
Canada: 1039 Cardiff Blvd. • Mississauga, Ontario L5S 1P4 • Canada

P: 913-780-1440 • TOLL FREE 800-447-3693 • F: 913-780-1427
E: info@superiorsignals.com • www.superiorsignals.com