

DLTT

Thinline Stop/Tail/Turn LED Lights



DLTT-121***
(12 VDC)

DLTT-241***
(24 VDC)



DLTT-124***
(12 VDC)

DLTT-244***
(24 VDC)

IMPORTANT: Please read all of the following instructions before installing your new light. Failure to follow these safety precautions may result in damage to your light or vehicle and may result in serious injury or death to you and your passengers.



This light utilizes high-intensity LED Lamps. DO NOT stare directly into the light while it is on, as momentary blindness and/or permanent eye damage may occur.

DLTT Functionality

- The DLTT Thinline LED Stop/Tail/Turn Light is designed to provide **auxiliary** warning lighting to your vehicle. It is **not D.O.T approved** and thus should not be used as a primary lighting system. It is NOT designed to replace the standard STT lights on your vehicle, but rather it should work in conjunction with them.
- The DLTT light can perform all three functions (Stop AND Tail AND Turn). Please note that the Tail lights are ignition switched and automatically activate and stay illuminated whenever the vehicle is running.
- Although one DLTT light can perform all three functions, you may also opt to use two or three DLTT lights, each performing a separate function.

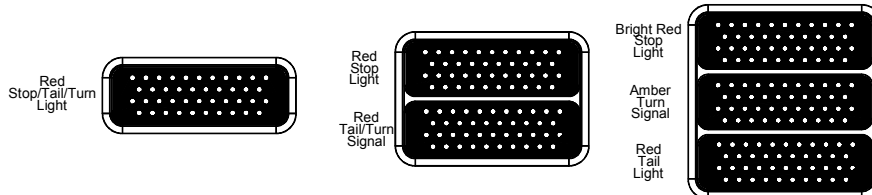

- If you need lights that flash in a warning pattern, rather than simply acting as supplemental Stop/Tail/Turn lights, order the DLXT or DLHT lights.

Important: This product is used to warn traffic. Improper use may result in vehicular collision, personal injury and/or death. Star Headlight & Lantern Co., Inc., and its subsidiaries shall not be held responsible for damages directly or indirectly caused by improper use of this product.

Installation Notes

- The installer must have a firm knowledge of basic electricity, vehicle electrical systems, and emergency equipment.
- If you need to drill any holes when installing this light, please take care to check that BOTH SIDES of your drilling surface are clear from obstructions, to ensure that you do not damage your vehicle and or pre-existing wiring.
- Choose a mounting location away from any air bag deployment areas.
- Controls should be placed within convenient reach of the driver.
- Use only soap and water when cleaning this product. Use of other chemicals may discolor the lens and/or housing, thus diminishing the output of the light. Lenses that have become discolored should be replaced immediately!
- DO NOT use a pressure washer to clean this light. Use of a pressure washer may damage the light and WILL VOID THE WARRANTY.

Wiring Notes



When wiring your lights, it is recommended that you take the following precautions to reduce any Electromagnetic Interference (EMI).

- Keep LED modules and any radios as far away from each other as possible.
- Separate the radio wires and the LED wires.
- Any excess wires should be cut short.
- The Ground, Power, and Synchronization wires should be bound tightly together as they run from light to light, through your switchbox, and finally to the battery.
- Do not ground each unit independently to the chassis. Run the ground for each unit in a "bus" like structure, to the negative terminal on the battery.

Surface Mounting Instructions

Please Note: These instructions are provided as a general guideline only. **Some vehicles may require special mounting, wiring, and/or weather-sealing. This is the sole responsibility of the installer.** Star Headlight & Lantern Co., Inc. assumes no responsibility for the integrity of the installation for this or any of its products.

1. Use the gasket as a template to mark your mounting holes.

Rubber Mounting Gasket (P30047-123)

Mark Screw Holes

- Drill $\frac{1}{8}$ " Holes for Self Tapping Screws
- Drill $\frac{5}{16}$ " Holes if Using Rubber Well Nuts

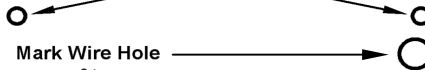

Mark Wire Hole

- Drill $\frac{3}{8}$ " Hole to Route Wires Through

2. Determine whether you are going to use the self-tapping screws or the machine screws and well nuts..
 - Use the self tapping screws for applications where the mounting surface is a minimum of .060" (1/16") thick and is composed of a material that will provide sufficient "bite" for the self tapping screw.
 - Use the machine screws and well nuts if your surface is less than .060" thick and/or composed of a material insufficient for securing with self tapping screws.

3. Route the wires as shown to the right:

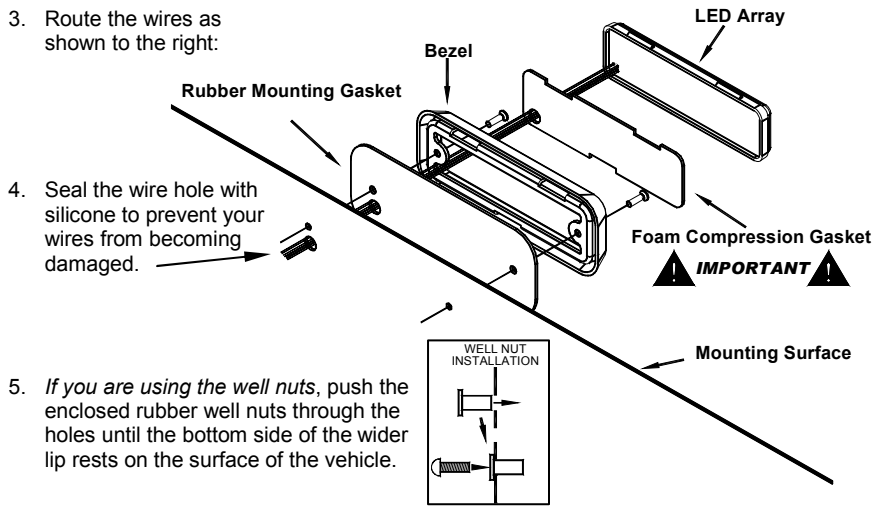

4. Seal the wire hole with silicone to prevent your wires from becoming damaged.

5. If you are using the well nuts, push the enclosed rubber well nuts through the holes until the bottom side of the wider lip rests on the surface of the vehicle.

6. Review the mounting diagram and use the appropriate screws to mount the bezel.



- Check the gasket to ensure it is resting flat and that there are no gaps between the light and the mounting surface.
- Take extreme caution not to over tighten the screws!!! Over tightening of the screws can strip the holes and result in a faulty mount.

7. Once the bezel is firmly attached to the mounting surface, seat the foam compression gasket inside of it. Carefully feed any loose wire into the wire and press the LED head into the bezel.

Wiring

Stop/Tail/Turn Functionality (one light - all 3 functions)

Black: (Ground) – Connect the Black wire to Ground.

Red: (Tail) – Connect the Red wire to the wire supplying power to the Tail light.

Green/White: (Turn Signal) – Connect the Green/White wire to the wire supplying power to the Turn Signal. This will allow the DLTT light to flash bright red in conjunction with the Turn Signal.

White: (Stop or Brake Light) – Connect the White wire to the wire supplying power to the brake light. When activated, the light will glow a bright red.

Green: (Programming only - See below) – Turn Signal Programming.

WIRING DIAGRAM FOR TRIPLE FUNCTIONALITY

(Auxiliary RED STOP, TAIL, & TURN)

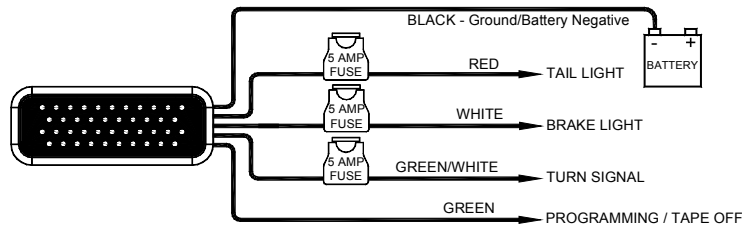

BASIC 4-WIRE TRAILER HARNESS WIRING DIAGRAM
TRIPLE FUNCTIONALITY - Auxiliary RED STOP, TAIL, & TURN

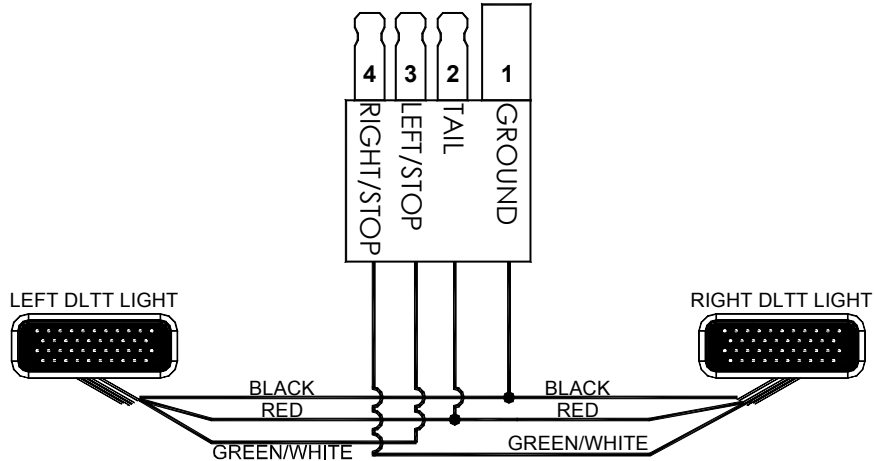

Optional Turn Signal Programming

Programming for External Flasher (Blinker) or Internal Flasher

By default the light is designed to operate off of your vehicle's flasher (blinker) using the Green/White wire. If you wish to use the internal flasher in the DLTT light instead, proceed below:

1. Connect the Black wire to Ground and the Red wire to power.
 2. Leave the White wire and the Green/White wire disconnected.
 3. Hold the Green wire to ground until the light flashes five times, then release it.
 The unit will now utilize its own internal flasher when steady power is applied to the Green/White wire.
- Repeat the steps above to revert the unit back to using an external flasher (blinker).

	<p>Please note that if you are connecting the Green/White wire to your blinker, leave the unit in the default "external flasher" mode. If you are using the DLTT's internal flasher, CONSTANT power must be applied to the Green/White wire for the DLTT to flash.</p>
--	-------------------------------------------------------------------------------------------------------------------------------------------------------------------------------------------------------------------------------------------------------------------------------

Programming The Flash Type

By default the TURN function (Green w/White wire) will flash the light ON and OFF. If you prefer your "blink" to be BRIGHT and DIM (rather than on/off), proceed below:

1. Connect the Black wire to Ground and the Red wire to power.
 2. Leave the White wire and the Green/White wire disconnected.
 4. Hold the Green wire to ground until the light flashes six consecutive times, then release it.
 The unit will now flash BRIGHT/DIM.
- Repeat the steps above to revert the unit back to ON/OFF flashing.

Stop or Tail or Turn Functionality
(one function per light)

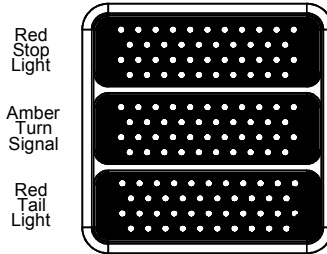

Stop Function Only:

Black: (Ground) – Connect the Black wire to Ground.

White: (Stop or Brake Light) – Connect to the wire supplying power to the brake light. When activated, the light will glow a bright red.

Red: (N/A) – Not used for Stop

Green/White: (N/A) – Not used for Stop

Green: (N/A) – Not used for Stop

Single Function Light
STOP

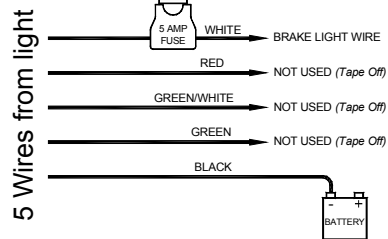

Turn Function Only:

Black: (Ground) – Connect the black wire to Ground.

Green/White: (Turn Signal) – Connect to the wire supplying power to the Turn Signal (blinker). This will allow the DLTT light to flash bright red in conjunction with the Turn Signal. (See **Optional Programming of Turn Signal Function** on previous page to use the DLTT's internal flasher by applying constant power to the Red wire and Green/White wire).

Red: (N/A) – Not used for Turn

White: (N/A) – Not used for Turn

Green: (N/A) – Not used for Turn

Single Function Light
TURN

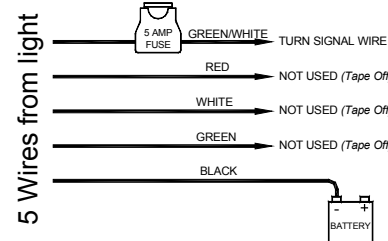

Tail Function Only:

Black: (Ground) – Connect the black wire to Ground.

Red: (Tail) – Connect the red wire to the wire supplying power to you Tail lights. This will illuminate the light in Tail mode (dim).

White: (N/A) – Not used for Tail

Green/White: (N/A) – Not used for Tail

Green: (N/A) – Not used for Tail

Single Function Light
TAIL

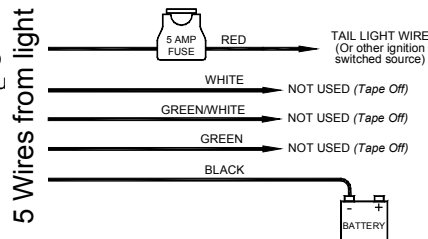

Wiring for One Turn and One Stop/Tail Functionality

See previous page for wiring a light as a Turn Signal.

Amber Turn Signal

Wiring for Stop/Tail Functions:

Red Stop/Tail Light

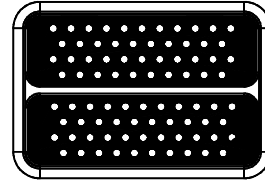

Dual Function Light STOP/TAIL

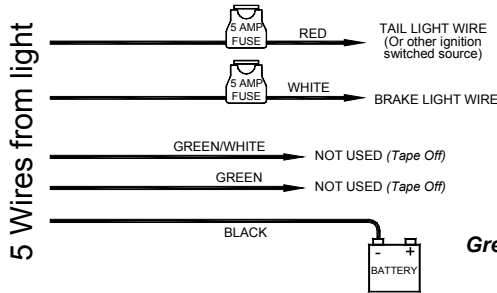

Black: (Ground) – Connect the Black wire to Ground.

Red: (Tail) – Connect the Red wire to the wire supplying power to the Tail light.

White: Connect the White wire to the wire supplying power to the brake light. When activated, the light will glow bright red.

Green/White: (N/A) – Not used for Stop/Tail.

Green: (N/A) – Not used for Stop/Tail.

Wiring for One Stop and One Turn/Tail Functionality

See previous page for wiring a light for Stop Light.

Red Stop Light

Wiring for Turn/Tail Functions:

Red Turn/Tail Light

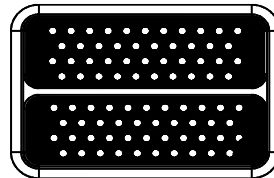

Black: (Ground) – Connect the Black wire to Ground.

Red: (Tail) – Connect the Red wire to the wire supplying power to the Tail light.

Green/White: (Turn Signal) – Connect the Green/White wire to the wire supplying power to the Turn Signal. This will allow the DLTT light to flash bright red in conjunction with the Turn Signal. (See **Optional Programming of Turn Signal Function** on page 3 to use the DLTT's internal flasher by applying constant power to the Green/White wire).

White: (N/A) – Not used for Turn/Tail.

Green: (N/A) – Not used for Turn/Tail.

Dual Function Light TURN/TAIL

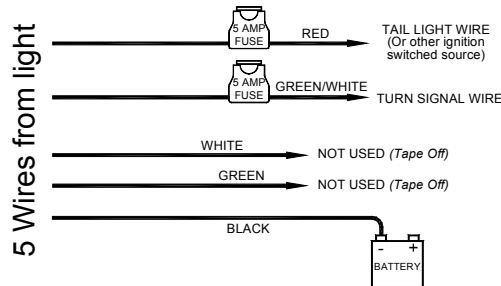

Troubleshooting Guide

These lights use state-of-the-art Light Emitting Diode (LED) technology. This light is comprised of ultra-bright LEDs that are operated in a multiplexed mode to efficiently produce light output with lifetimes up to 100,000 hours. Under normal circumstances, you will not need to replace any LEDs in this light. If any of the LEDs in your light do fail, please contact Star Headlight for arrangements to have them repaired.

NOTE: Most failures can be traced to wiring and battery problems. Check "quick-connects" and wiring to insure that correct voltage/polarity is reaching the light.

Symptom	Possible Cause	Check
No Light	Power or polarity	A nominal +12VDC (or +24VDC for 24V models) should be reaching the red wire Is power hooked up backwards? Positive ground vehicle? (Unit designed for negative ground vehicles)
	Inline fuse blown	Is an external fuse or circuit breaker used?
	Bad ground	Are the negative leads connected to a good ground?
	Green wire shorted	Green wire should remain unconnected. If grounded, light will cease to function.
	Shorts	Do wires run thru bare metal holes that have damaged them? Are the wires pinched or broken anywhere?
LED's appear dim	Low battery voltage	Measure: Voltage below 12V (or +24VDC for 24V models), LED output will be reduced.
	Power wires are too small/long	Measure: Voltage below 12V (or +24VDC for 24V models) @ the unit, LED output will be reduced.
Erratic operation	Bad routing of wires	Do wires run thru bare metal holes that have damaged them? Are the power or control wires close to: Strobe power supplies, tubes, cables, police/two-way radios or alternator? Try running with the car and all other accessories off

If you have any questions concerning this or any other product, please contact our **Customer Service Department** at (585) 226-9787.

If a product must be returned for any reason, please contact our Customer Service Department to obtain a Returned Goods Authorization number (RGA #) before you ship the product back. Please write the RGA # clearly on the package near the mailing label.

Optional Mounting

There are also seven (7) optional mounting brackets for units with single rectangular bezels, if you do not wish to surface mount them. A diagram of these optional mounts can be found on the following page.

274-DLXT-U	Universal "L"-Bracket
274-DLXT-W	Side (Vertical) Window Bracket
274-DLXT-T	Trunk Bracket
274-DLXT-45	45° Angled Bracket
274-DLXT-2X1	"L"-Bracket For Mounting Two Stacked Lights
274-DLXT-1X2	"L"-Bracket For Mounting Two Side-by-Side Lights
274-DLXT-RL	Rear License Plate Bracket for Mounting Two Lights

Oval lights can also be mounted using an optional rubber grommet (**P/N 527**) that is designed to fit into the standard oval light housings found on most commercial vehicles.

Please Note: These instructions are provided as a general guideline only. **Some vehicles may require special mounting, wiring, and/or weather-sealing. This is the sole responsibility of the installer.** Star Headlight & Lantern Co., Inc. assumes no responsibility for the integrity of the installation for this or any of its products.

LED FIVE YEAR LIMITED WARRANTY

The manufacturer warrants this LED light against factory defects in material and workmanship for five years after the date of purchase. The owner will be responsible for returning to the Service Center any defective item(s) with the transportation costs prepaid. The manufacturer will, without charge, repair or replace *at its option*, products, or part(s), which its inspection determines to be defective. Repaired or replacement item(s) will be returned to the purchaser with transportation costs prepaid from the service point. A copy of the purchaser's receipt must be returned with the defective item(s) in order to qualify for the warranty coverage. Exclusions from this warranty include, but are not limited to, domes, and/or the finish. This warranty shall not apply to any light, which has been altered, such that in the manufacturer's judgment, the performance or reliability has been affected, or if any damage has resulted from abnormal use or service.

There are no warranties expressed or implied (including any warranty of merchantability or fitness), which extend this warranty period. **The loss of use of the product, loss of time, inconvenience, commercial loss or consequential damages, including costs of any labor, are not covered.** The manufacturer reserves the right to change the design of the product without assuming any obligation to modify any product previously manufactured.

This warranty gives you specific legal rights. You might also have additional rights that may vary from state to state. Some states do not allow limitations on how long an implied warranty lasts. Some states do not allow the exclusion or limitation of incidental or consequential damages. Therefore, the above limitation(s) or exclusion(s) may not apply to you.

If you have any questions concerning this or any other product, please contact our **Customer Service Department** at (585) 226-9787.

If a product must be returned for any reason, please contact our Customer Service Department to obtain a Returned Materials Authorization number (RMA #) before you ship the product back. Please write the RMA # clearly on the package near the mailing label.



PROUDLY MADE IN THE USA
An ISO 9001:2008 Certified Company

NOTICE

Due to continuous product improvements, we must reserve the right to change any specifications and information, contained in this manual at any time without notice. Star Headlight & Lantern Co., Inc. makes no warranty of any kind with regard to this manual, including, but not limited to, the implied warranties of merchantability and fitness for a particular purpose. Star Headlight & Lantern Co., Inc. shall not be liable for errors contained herein or for incidental or consequential damages in connection with the furnishing, performance, or use of this manual.

