

# INSTALLATION AND INSTRUCTION MANUAL

## LCS850MG

### SIREN AMPLIFIER & LIGHT CONTROLLER



PROUDLY MADE IN THE USA  
An ISO 9001:2008 Certified Company



**Star Headlight & Lantern Co., Inc.**

455 Rochester Street Avon, NY 14414 Phone: 585-226-9787 FAX: 888-478-2797

**STAR**  
WARNING SYSTEMS

**STAR**  
SIGNAL  
VEHICLE PRODUCTS

**BRADFORD**  
Vehicle Solutions

[www.starheadlight.com](http://www.starheadlight.com)

**INSTALLATION INFORMATION**

**MODEL: LCS850MG**

**AMPLIFIER SERIAL #:** \_\_\_\_\_

**CONTROL HEAD SERIAL #:** \_\_\_\_\_

**PURCHASE DATE:** \_\_\_\_\_

**DEALER:** \_\_\_\_\_

**INSTALLER:** \_\_\_\_\_

**INSTALLATION DATE:** \_\_\_\_\_

**CONTROL HEAD DIP SWITCH OPTIONS**

- \_\_\_\_\_ Keypad Beep
- \_\_\_\_\_ Gun Lock
- \_\_\_\_\_ TD Mode
- \_\_\_\_\_ AUX Wire
- \_\_\_\_\_ Audio Pursuit
- \_\_\_\_\_ Visual Pursuit
- \_\_\_\_\_ Progressive Slide Switch
- \_\_\_\_\_ TD Output
- \_\_\_\_\_ Auto On
- \_\_\_\_\_ Magnum Mode
- \_\_\_\_\_ Radio
- \_\_\_\_\_ Phaser
- \_\_\_\_\_ Sweep

**AMPLIFIER DIP SWITCH OPTIONS**

- \_\_\_\_\_ AUX Input Polarity
- \_\_\_\_\_ Park-Kill Polarity

**TRAFFIC DIRECTOR DIP SWITCH OPTIONS**

- \_\_\_\_\_ Phantom Mode
- \_\_\_\_\_ Fast Rate Arrow
- \_\_\_\_\_ Low Power
- \_\_\_\_\_ 6-Head Arrow
- \_\_\_\_\_ Full 8-Head Arrow
- \_\_\_\_\_ Dual Travelling Arrow
- \_\_\_\_\_ Double Blink End

**TABLE OF CONTENTS**

<b>OVERVIEW</b> .....	<b>1</b>
<b>PRECAUTIONS</b> .....	<b>2</b>
<b>CONTENTS</b> .....	<b>2</b>
<b>SPECIFICATIONS</b> .....	<b>3</b>
<b>INSTALLATION</b> .....	<b>4-44</b>
<b>INSTALLER-SELECTABLE OPTIONS</b> .....	4-34
Control Head DIP Switch Settings.....	4-8
Overview Chart.....	4
BUZZ (Beep Settings), Gun Lock, Traffic Director Mode, AUX (Auxiliary Input).....	5
Audio Pursuit, Progressive Slide Switch, TD Output.....	6
Auto On, Magnum Mode.....	7
Radio, Phaser, Sweep, Programming Mode.....	8
Amplifier Dip Switch Settings.....	9
Traffic Director Settings.....	10-13
Standard 8-Output Mode (DIP Switches).....	10-12
Traffic Directors With Internal Controllers.....	13
Programmable Settings.....	14-34
<i>Detailed Programming Summary Table of Contents</i> .....	14
Detailed Programming Legend.....	15
Detailed Programming Instructions.....	16-34
(see page 14 for specific page numbers for each option).....	16-34
<b>RESETTING UNIT TO DEFAULTS</b> .....	34
<b>QUICK INSTALLATION GUIDE</b> .....	<b>CENTERFOLD</b>
MOUNTING.....	35-37
ELECTRICAL CONNECTIONS.....	38-44
Power and Ground Connections.....	39
10-terminal Connector (SS and Pushbutton Outputs).....	40
Siren Wiring Diagram #1.....	41
Label Insertion.....	42
12-terminal Connector (Audio I/O).....	43
Siren Wiring Diagram #2.....	44
LCS850MG-XF12 Microphone Harness.....	45
<b>OPERATION</b> .....	<b>46-50</b>
SLIDE SWITCH.....	46
PUSH BUTTON SWITCHES.....	46
AUDIO MODE BUTTONS.....	47
VOLUME CONTROLS.....	47
MANUAL BUTTONS.....	48
Chart of Manual Tones.....	48
AIR HORN 48.....	
Chart of AUX Terminal/HRT Activation.....	49
MAGNUM MODE.....	49
TRAFFIC DIRECTOR CONTROL BUTTONS.....	50
SPEAKER DIAGNOSTICS.....	50
MICROPHONE.....	50
AUXILIARY INPUT.....	50
PARK KILL.....	50
<b>CLONING</b> .....	<b>51</b>
<b>SERVICE</b> .....	<b>52-55</b>
FUSES.....	52
PARTS.....	52
TROUBLESHOOTING.....	53
WARRANTY.....	54
RETURN.....	54
RETURNED GOODS AUTHORIZATION FORM.....	55
<b>CONTROL HEAD INSTALLATION TEMPLATE</b> .....	<b>Inside Back Cover</b>

## Overview

The LCS850MG Siren Amplifier is a premium 200W unit designed for dual 100W speaker use and full lighting control. It comes standard with a remote control head and a noise-cancelling microphone for PA use. The amplifier box contains two separate amplifiers that allow the user to operate two separate and distinct tones at the same time. This dual tone (Magnum) feature creates a unique sound that is one of the most attention getting amplifiers on the market today. The Magnum sound allows a single vehicle to sound like several vehicles traveling at the same time. Each amplifier can operate one 100W RMS speaker.

The primary operating modes are Phaser, Yelp, Wail, Hands Free, Manual, and Radio. A Noise Canceling PA Override and push-button Horn Override are available in all modes. A manual push-button is provided for push-on/push-off tone toggle operation in the Phaser, Yelp, and Wail modes. It also allows manual siren control in the HF and silent modes. The Phaser function can be optionally replaced by Two-Tone or disabled entirely with programming. Another feature allows cycling through Wail, Yelp, Phaser, and Standby by providing a signal to the horn ring auxiliary wire when the function switch is in the Hands Free (HF) position. A Park Kill option is provided for connection to a door switch, etc. to disable the siren when exiting the vehicle. Radio and PA volume controls are provided on the front panel. Also located on the front panel are two LED's for speaker diagnostics.

This unit additionally contains several distinct controls for operation of vehicle devices. A slide switch allows quick pursuit mode operation. The far right slide position can be set up to activate maximum lights and siren for pursuit mode. There are seven push buttons to control up to seven different lighting or auxiliary functions, or six functions and a traffic director.

The front panel is backlit with LED's for night visibility. This compact unit utilizes short circuit, high voltage, low voltage, and reverse polarity protection systems for maximum service life.

### Questions?

Signal Vehicle Products will attempt to answer and resolve any questions or issues you may have. Please contact our Customer Service Department at the number below with any questions. **When contacting us about a product you have purchased, please have the product's serial number readily available.**

**Phone: (585) 226-9025**  
**Fax: (888) 478-2797**  
**[www.starheadlight.com](http://www.starheadlight.com)**

### NOTICE

Due to continuous product improvements, we must reserve the right to change any specifications and information, contained in this manual at any time without notice. Signal Vehicle Products and/or the manufacturer make no warranty of any kind with regard to this manual, including, but not limited to, the implied warranties of merchantability and fitness for a particular purpose. Signal Vehicle Products and/or the manufacturer shall not be liable for errors contained herein or for incidental or consequential damages in connection with the furnishing, performance, or use of this manual.

## Precautions

Proper installation of the unit is essential for years of safe, reliable operation. Please read all instruction **before** installing the unit. Failure to follow these instructions can cause serious damage to the unit or vehicle and may void warranties.

- Installing any siren requires a good understanding of automotive electronics, systems, and procedures.
- Please read all of the instructions, before attempting to install or operate any of the sirens.
- Always disconnect power when installing or uninstalling this device.
- Never use a battery charger to bench test this device.
- This product is intended to be installed and operated in interior applications only.

**Keep These Instructions** - Keep these instructions in the vehicle or other safe place for future reference. Advise the vehicle operator of the location.

**Unpacking** - Inspect contents for shipping damage. If found, alert carrier immediately.

## Contents

Contents should include:

- 1 - Siren with Microphone
- 1 - Mounting Bracket w/Screws (*Non-Flange version only*)
- 1 - Microphone Bracket w/Screws
- 3 - Wiring Connectors
- 1 - Pack of Button Labels
- 1 - Wire Bundle
- 1 - Installation and Operating Instructions

Contact your supplier immediately if any components are missing.

**Specifications**

Input Voltage	10 - 16 VDC (negative ground)
Input Current	8.0 Amps @ 13.6 VDC (single 100W speaker) 16.0 Amps @ 13.6 VDC (dual 100W speakers)
Standby Current	0 mA while Off, <150 mA with backlighting on
Max Peak Current	50 AMPS (supply circuit must be capable of supplying this for brief period)
Audio Frequency	200Hz - 10 kHz + 3db
Audio Output	40 watts @13.6 VDC
Output Power	105 WATTS RMS MAX. (15.0 VDC – single 100W speaker) 180 WATTS RMS MAX. (15.0 VDC –dual 100W speakers)
Siren Frequency	675Hz - 1633Hz
High Voltage Protection	16 - 18 VDC will cause siren output to cease, resumes at normal voltage
Operating Temperature	-15° F to +140°F
Siren Controls	5 pushbutton selectable audio modes-(HF, Wail, Yelp, Phaser, Radio) Push-Button Manual and Horn switches Auxiliary input (DIP switch programmable) for positive or negative horn Remote Manual or Hands Free operation Park Kill input (DIP switch programmable) for positive or negative activation Phaser (and Two-Tone) disable (programmable) Two-Tone activation (swaps modes with Phaser) (programmable)
Diagnostic Indicators	Two LED indicators provide diagnostic feedback for each speaker
Light/Device Controls	7 push-on/push-off buttons 4-position slide switch (Off, ①, ②, and ③)
Light Output Ratings	20A fuse on each of the 10 outputs. (7 push buttons, 3 slide positions)
Siren and Light Connections	Detachable 12-terminal connector Detachable 10-terminal connector 1 individual Ground terminal, 3 +12VDC power terminals
Size	7-5/8" Wide, 9-7/8" Deep, 2-1/8" High
Shipping Weight	7 lbs.

## Installation

Signal Vehicle recommends that you bench test the unit immediately after receipt to ensure that it was not damaged in shipping. Then you should program all settings and test again prior to installation.

**For quick installation using all of the default options, please refer to the removable centerfold guide.**

### Optional Settings

The LCS850MG has many different optional settings that can be set with DIP switches or programmed to meet your particular needs. Please review pages 4-34 (Control Head DIP switches below, Amplifier DIP Switch Settings on page 9, Traffic Director Settings on page 10, and Detailed Programming on page 14) to determine if you need to change any of the settings for your application. **If you need to make any changes to the default settings, please do so prior to installation of the siren.**

### Control Head DIP Switch Settings Overview

*(Continue to the next page for detailed descriptions)*

<u>Option</u>	<u>Default Setting</u>	<u>Optional Setting</u>
Keypad Beep (BUZZ).....	Enabled.....	Silent.....
Gun Lock Button.....	Enabled.....	Standard On/Off Button.....
PB13 Traffic Director Mode.....	Enabled.....	No Traffic Director.....
Aux Wire Control.....	Air Horn.....	Clone Manual Function.....
Audio Pursuit.....	Enabled/Programmable.....	Disabled.....
Visual Pursuit.....	Enabled/Programmable.....	Disabled.....
Progressive Slide Switch.....	Progressive.....	Programmable or Non-Progressive.....
Traffic Director Output.....	Discrete/8-Output.....	Logic Control (3 or 4 outputs).....
Auto On @ Boot.....	No Buttons on @ Boot.....	Programmed Buttons on @ Boot.....
Magnum Mode @ Boot.....	Enabled.....	Disabled.....
Radio Button.....	Enabled.....	Disabled/Lighting Control.....
Phaser Button.....	Enabled.....	Disabled/Lighting Control.....
Tone Sweep in HF Mode.....	Automatic.....	Manual.....
Programming Mode.....	Off/Normal Operation.....	On (Set Up Mode).....

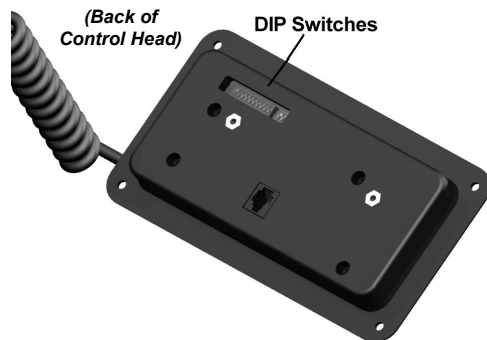

There are 14 DIP switches located on the back of the Control Head. The default position for all of them except for Gun Lock (DIP switch 2) is "down".

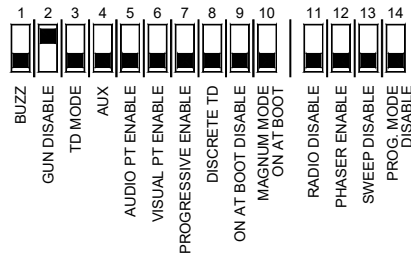

**Detailed DIP Switch Information**

**BUZZ (Beep Settings)**

By default, every time a button is pressed on the keypad, the unit beeps. Flip the BUZZ DIP switch up to deactivate this feature.

**Please note:** There is also an optional 10-second beep setting that can be set to beep every 10 seconds when ANY function is active. The optional 10-second beep function will not work if this switch is in the UP position (see page 18 of the **Detailed Programming** section for further details).

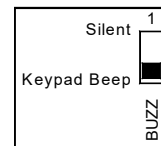

**GUN DISABLE**

**PB14** is defaulted as a 10 second "Gun Lock" button. If you will not be using the Gun Lock option, flip switch 2 down. **PB14** will then become a standard ON/OFF button.

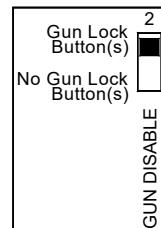

**TD Mode (Traffic Director Mode On/Off)**

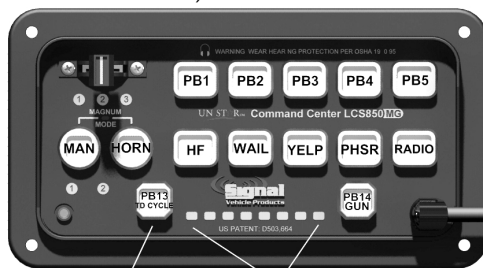

TD CYCLE Button      TD Indicator LEDs

**PB13** is normally used to control an approved traffic director (arrowstick) by scrolling through the four main traffic directing patterns: WARN, LEFT, RIGHT, and CENTER OUT. Flip DIP switch 3 up to disable the traffic director mode and to use **PB13** for ON/OFF control of the **PB13** output (see wiring diagram on page 41), .

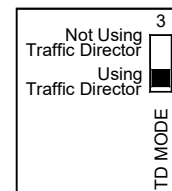

**AUX (Auxiliary Wire Input Function)**

Normally the siren Air Horn can be activated by using the vehicle horn switch (or other external switch) to apply +12VDC to the auxiliary input (terminal 7 of the 12-terminal connector, see pages 43-44).

If you instead prefer to have the AUX wire activate your Manual function, flip DIP switch 4 up.

**NOTE:** If the AUX wire DIP switch is set for the MANUAL function (and the HRT is connected), neither your vehicle horn, nor the siren Air Horn will sound when you press your steering wheel horn during a siren tone.

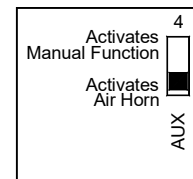



**AUDIO PURSUIT ENABLE (DIP switch 5) and VISUAL PURSUIT ENABLE (DIP switch 6)**

Normally slide switch position ③ activates "Pursuit Mode":

- The lights connected to all 3 slide switch positions will activate.
- The siren will activate in Wail mode.
- Your compatible traffic director (if connected to this unit) will activate in the Warn mode.

To disable automatic activation of the siren (**AUDIO PURSUIT**) in position ③, flip DIP switch 5 up.

To disable automatic activation of the traffic director (**VISUAL PURSUIT**) in position ③, flip DIP switch 6 up.

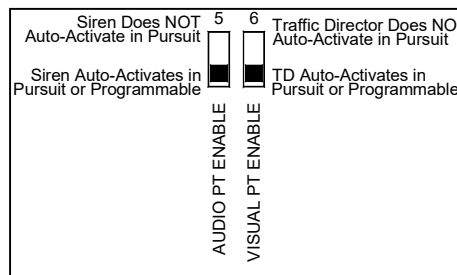

**PROGRESSIVE ENABLE (Progressive Slide Switch Enable)**

Normally the slide switch is "progressive", meaning that each position will add another function while keeping the previous one(s) on. Position ① activates the first function. Position ② activates the functions connected to both ① and ②. Position ③ will activate all of the functions connected to ①, ②, and ③.

To disable this feature so that each slide switch position is independent from the others, flip DIP switch 7 up.

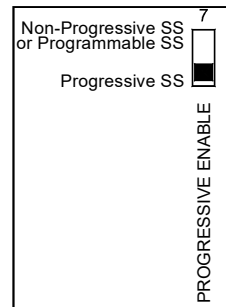

**DISCRETE TD (Traffic Director Compatibility: 8-Output or 4-Output Logic)**

TD Mode DIP switch (switch #3) must be ON (see page 5)!!

**The default settings of this unit allow for operation of our standard 8-head traffic directors** (i.e. TD77, TD92, TD93) through an internal controller within the LCS850MG using 10 outputs from the 12-terminal connector.

If the traffic director you will be using has a built-in controller and only needs three or four "signal" wires to operate, then flip DIP switch 8 up.

With this switch up, the default setting will be for operation of our DL15-30W. To program the LCS850MG to operate other traffic directors, please refer to page 32 of the Detailed Programming section.

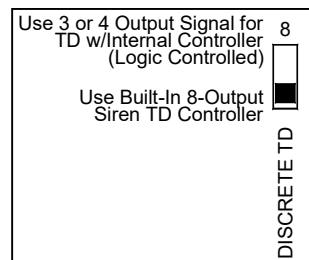

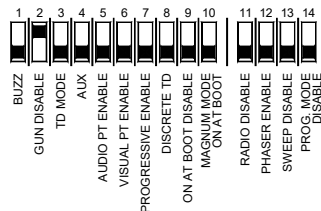

### ON AT BOOT DISABLE (Push Button State At Power Up)

If you would like any of the push button switches to automatically be "ON" when the unit is powered up, flip DIP switch 2 up. By default, if you flip switch 9 up, **PB5** will be ON at boot up.

Please see page 17 of the Detailed Programming section for further instructions on selecting which buttons you would like "ON" at power up.

**Please note:** The switches still function normally as an On/Off switch in either mode. This option only allows you to select whether the switch is automatically On or automatically Off when the unit is powered up.

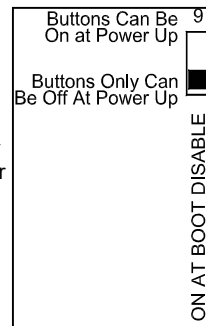

### MAGNUM MODE ON AT BOOT (On At Power Up)

(For details on **Magnum Mode** see page 48)

Normally, the siren is in Magnum mode at boot up. If you would like it to be in standard mode (non-Magnum/single tone), flip the 10th switch from the left (switch 10) up.

**Please Note:** This option only affects which mode the siren is in at boot. Magnum Mode can still be switched to at any time.

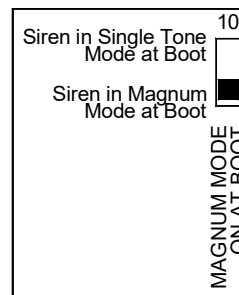

### RADIO DISABLE (Radio Rebroadcast or ON/OFF Switch for Output 7)

Normally, the RADIO button is used to rebroadcast the two-way radio over the PA system of the siren. If you will not be using this feature, you can instead use the RADIO button to control the **PB13** output (see the wiring diagram on page 41).



To use the RADIO button to control the **PB13** output, flip DIP switch 11 up.

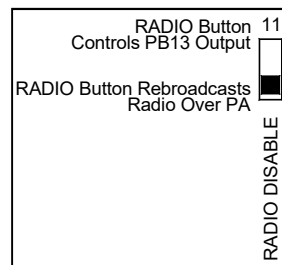

**NOTE :** To use the RADIO button to control the **PB13** output, the TD MODE DIP switch (#3) MUST also be in the DOWN position.

### PHASER ENABLE (Optional Phaser Tone or ON/OFF Switch for the PB13 output)

Normally, the PHASER button is used to activate the Phaser siren tone. If you will not be using this feature/tone, you can use the PHASER button to control the **PB13** output (see the wiring diagram on page 41) by flipping DIP switch 12 UP.

**NOTE** : The PHASER Button cannot be used to control the **PB13** output if either DIP switch #3 (TD MODE) or DIP switch #11 (RADIO) is UP (those options override this one).

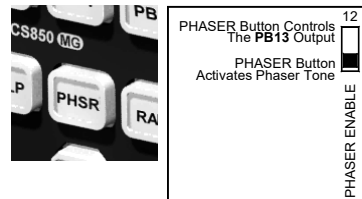

### SWEEP DISABLE ('Manually Cycle' or 'Auto-Sweep' Siren Tones in HF Mode)

When the siren is placed in Hands Free Mode (by pressing the HF button), no sound will be initially produced. Normally, activating the Auxiliary Input/HRT (see page 43 of the **Electrical Connections** section) or moving the slide switch to position ③, will activate the siren with a "WAIL" tone. Then you can manually cycle through all of the tones using the AUX input/HRT.

(WAIL ⇒ YELP ⇒ PHASER/TWO-TONE ⇒ OFF).

If you instead would like the siren to automatically "sweep" through all of the tones when activated, flip DIP switch 13 up.

(Optionally if you'd like the sweep option described here to only function in HF with the AUX input, and NOT in Slide Switch ③, then see the **Tone Sweep Disable** section on page 28).

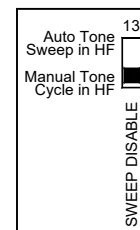

### PROG. MODE DISABLE (Programming Mode)

To access the additional "programmable" options described in the **Detailed Programming** section on pages 14-34, flip this switch up. After programming the siren, return the switch to the Standard Operation location.

**NOTE** : The siren WILL NOT operate while in Programming Mode. DIP switch 14 must be in the "down" position for proper operation of the siren.

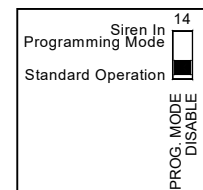

## Amplifier DIP Switch Settings

There are four additional DIP switches located on the amp box near the connectors (see *diagram below*). These four switches are used to control the polarity of your Auxiliary function and your Park-Kill function.

There are TWO switches that must be set for Auxiliary Polarity and TWO switches that must be set for Park-Kill Polarity. **You must set BOTH switches correctly for each function.**

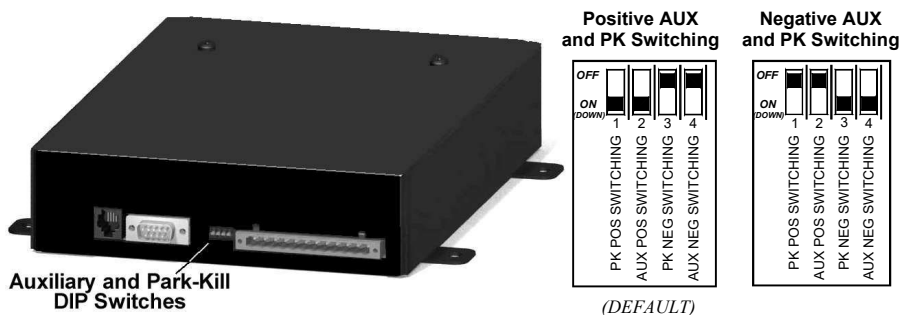

### Auxiliary Input Polarity

The auxiliary input (see **AUX WIRE** on page 5 and see **Terminal 7** of the 12-terminal connector on page 43) is normally activated by connecting terminal 7 to positive voltage (+12VDC). (See **Positive Switching AUX and PK Switching** diagram above).

To activate the AUX function by connecting the corresponding terminal to ground (negative) instead, turn switch 2 (AUX POS SWITCHING) "OFF" and turn switch 4 (AUX NEG SWITCHING) "ON" (see **Negative Switching AUX and PK Switching** diagram above).



### Park-Kill Polarity

The Park-Kill input (**Terminal 3** of the 12-terminal connector, see page 43) is used to automatically turn off any siren tone output when activated (i.e. vehicle shifted into park, door opened, etc.). The tones will remain off until a control on the siren is activated. The wiring diagram on page 44 shows two connection examples.

The park kill input is normally activated by connecting it to positive voltage (+12VDC). (See **Positive Switching AUX and PK Switching** diagram above).

To activate the Park-Kill feature by connecting it to ground (negative) instead, turn switch 1 (PK POS SWITCHING) "OFF" and turn switch 3 (PK NEG SWITCHING) "ON" (see **Negative Switching AUX and PK Switching** diagram above).



## Traffic Director Settings

This section only applies to those applications in which the **TD CYCLE** on the control head will be used to operate a traffic director (arrowstick). If you are NOT using this button to control a traffic director, you can skip to page 14, after ensuring that DIP switch 3 (TD MODE), on the back of the Control Head, is in the **OFF** position (see page 5).

**PB13** is normally used as a **TD Cycle** button to control an approved traffic director (arrowstick) by scrolling through the four main traffic directing patterns: **WARN, LEFT, RIGHT, and CENTER OUT**. Pressing this button will activate your traffic director and will illuminate the **TD Indicator LEDs** on the bottom of the control head in the same pattern that the traffic director is displaying.

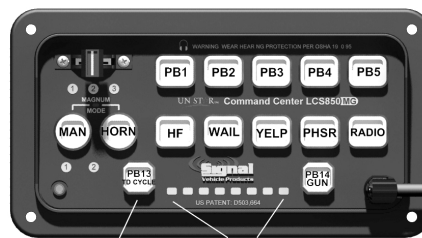

TD CYCLE Button      TD Indicator LEDs

By default, the LCS850MG is compatible with any of our ground-side switched 8-head traffic director (e.g. TD77, TD92, TD93, etc.) and will use its own internal controller to drive the "dummy" heads in the traffic director. The *Standard 8-Output Mode* is also compatible with 6-head traffic directors (e.g. lightbars with only 6 TD heads) or 8-head TDs in which only 6 heads are used in the traffic directing pattern (and the heads on each end are flashed back and forth).

If your traffic director has a built-in TD controller and only requires "Signal" or "Logic" inputs (e.g. the DL15-30W), there are also three (3) additional TD compatibility modes. Skip to page 13 if you will be using a controller that is already built in to your traffic director.

### Standard 8-Output Mode (default setting)

This section only applies to those Traffic Directors that normally require a separate control box and use inputs for each individual head. Skip to page 13 if you will be using a controller that is already built in to your traffic director.

If you will be using the internal controller of the LCS850MG to operate your traffic director, please verify that DIP switches 3 and 8 on the back of the control head are set properly. (See pages 5 & 6)

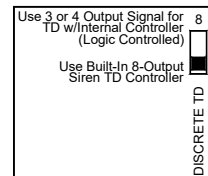
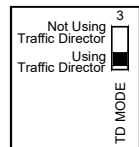
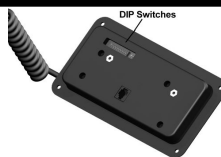

Connect the 10 wires from your traffic director harness to the 12 -terminal connector that plugs into the back of the LCS850MG-AMP box. The last two terminals of the connector will be empty.

**If you are only controlling six heads, do not use terminals 1 and 8.**

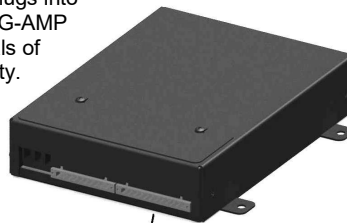

12-Terminal Connector for 8-Output Traffic Director

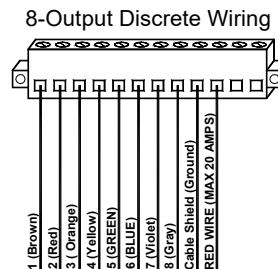

Traffic Director Harness

**Internal TD DIP Switches**

There are several additional programmable options for standard 8-head (or 6-head) traffic directors that utilize the internal controller. Review these options below and determine if you will need to change any of the default settings.

Loosen the two Phillips head screws securing the access panel cover and lift it off.

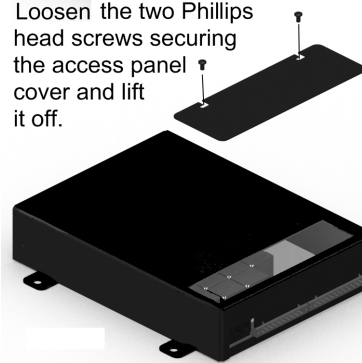

**TD DIP Switch Access**

1. Loosen the two Phillips head screws that secure the access cover to the top of the siren.
2. Locate the DIP switches inside the housing towards the right hand side.
3. There are two banks of four switches.
4. Replace the cover when finished.

**Phantom Mode (switch 4/bank 1)**

- Phantom Mode is designed to use 6 of the 8 heads for traffic directing.
- In the Phantom mode, the end lights are **NOT** part of the "traffic directing" patterns.
- Both of the end lights will flash back and forth in a high speed "warn" type display any time the slide switch is in position 2.
- The end lights of your traffic director automatically flash in a "random flicker" pattern with the slide switch in position 3 (see **TRAFFIC DIRECTOR VISUAL PURSUIT** on page 31).



Normally the LCS850MG will use all 8 heads as part of the traffic directing pattern. To switch to Phantom mode, move DIP switch 4 (on the far left of the first bank of DIP switches) AWAY the edge of the siren (UP).

**Phantom Mode**

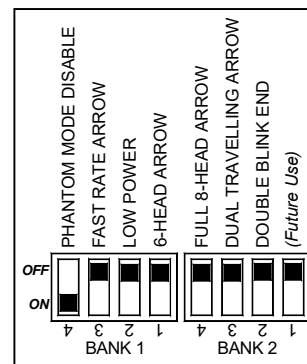
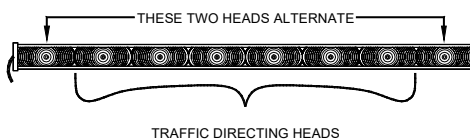

**Fast Rate Arrow (switch 3/bank 1)**

This option will "speed up" the flash rate of the arrowstick. Typically this is used for high speed or high traffic areas where viewing time of the arrow is limited. To set your arrowstick to display a "Fast Arrow", move DIP switch 3 of the first bank of DIP switches TOWARDS the edge of the siren (DOWN).

**Low Power** (switch 2/bank 1)

If the arrow stick is to be used for nighttime operation, or you wish to reduce the power consumption of the arrow stick, the output can be reduced by 50%. To set your arrowstick to run under Low Power, move this DIP switch TOWARDS the edge of the siren.

**Six Head Arrow** (switch 1/bank 1)

This option should be used if your traffic director contains only six heads. In this mode, under all patterns the 1<sup>st</sup> & 8<sup>th</sup> heads will alternate back & forth, operating as rear flashers. This differs from **Phantom Mode**, which flashes the end heads only when the Slide Switch is in position ② or ③. (NOTE: This option is NOT available if the controller set for Phantom Mode.) If you wish to operate your traffic director in 6-Head mode, then move this DIP switch TOWARDS the edge of the siren.

**Full 8-Head Arrow** (switch 4/bank 2)

Many arrow sticks contain directional arrows (actual "points") on either end (the 1<sup>st</sup> and 8<sup>th</sup> heads). Because of this, the default setting is for a 7-head pattern that will automatically skip the first head in the right or left patterns so as to not confuse the driver with the incorrect arrow direction. If your arrow stick does not contain directional arrows on the ends and you wish to use all eight heads in your right and left patterns, then move this DIP switch TOWARDS the edge of the siren. (This option is not available if the controller is set for Phantom Mode.)



**Dual Traveling Arrow** (switch 3/bank 2)

Normally, when the traffic director is in one of its "arrow" modes (Right or Left), the arrow will start on one side and illuminate the lights, adding one at a time. Optionally, you may choose a Dual Travelling Pattern, where energy saving is desired. In this case only two heads will illuminate at any given time, and "travel" across the arrowstick in the direction you select. (NOTE: The Dual Travelling Pattern option is NOT available if the controller set for Phantom or Double Blink Mode.) If you wish to use the Dual Travelling Pattern instead of the Standard Pattern, then move this DIP switch TOWARDS the edge of the siren.

**Standard Left Arrow Pattern**

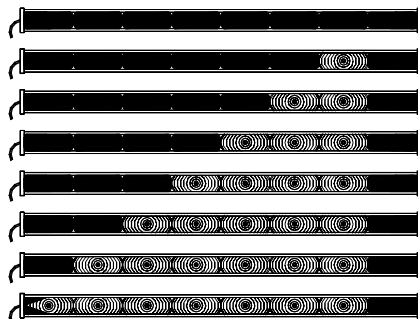

**Dual Travelling Left Arrow Pattern**

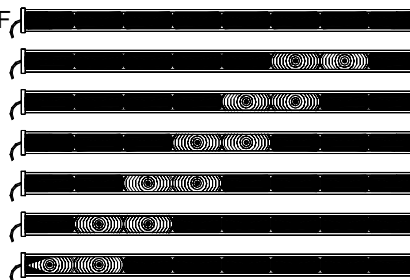

**Double Blink Last Head** (switch 2/bank 2)

The last head to flash in an arrow can be optionally selected to blink twice at the end of the arrow sequence. (NOTE: The Double Blink Last Head option is NOT available if the controller set for Phantom Mode.) If you wish to Double Blink the last head, move this DIP switch TOWARDS the edge of the siren (DOWN).



**Traffic Directors with Built In Controllers (Logic Controlled)**

This section only applies to those Traffic Directors that have a built-in controller, but will be operated with the **TD CYCLE** button through “signal” wires.

The LCS850MG has three different “logic controlled” modes that can be used, depending upon the input requirements of your Traffic Director. These are as follows:

**DL15-30W Configuration:** Stick operated with 4 wires (Warn/Power, Left, Right, and C/O)  
Left Arrow activated by power to Warn+Left wires from stick  
Right Arrow activated by power to Warn+Right wires from stick  
C/O activated by power to Warn+C/O wires from stick  
WARN pattern activated by Warn/Power wire

**Alt. TD Configuration #1:** Stick operated with 3 wires (Warn, Left, and Right)  
Warn, Left, and Right each operate independently  
C/O activated by power to only Left+Right wires from stick

**Alt. TD Configuration #2:** Stick operated with 3 wires (Center-Out, Left, and Right)  
C/O, Left, and Right each operate independently  
No Warn Pattern

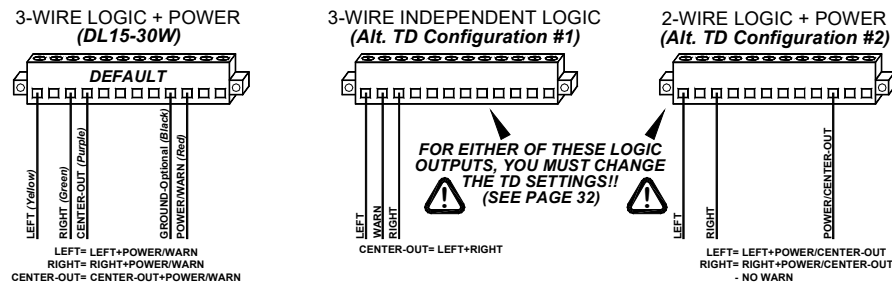

If you will be using the **TD CYCLE** button on the LCS850MG control head to operate your “logic controlled” traffic director i.e. its own internal controller), please verify that DIP switches 3 and 8 on the back of the control head are set properly. (See pages 5 & 7)

Review the appropriate diagram above and connect the necessary wires from your traffic director harness to the corresponding terminals on the 12-terminal connector that plugs into the back of the LCS850MG-AMP box.



12-Terminal Connector for 8-Output Traffic Director

**See page 32 to program the siren for each of the appropriate configurations described above.**

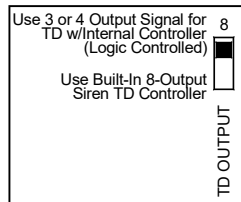
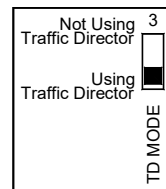



### Detailed Programming Summary Table

**The options below should be programmed PRIOR to installation of your siren.  
Refer to pages 15-34 for detailed programming instructions.**

<u>Option</u>	<u>Default Setting</u>	<u>Optional Setting</u>	<u>PG</u>
Button Operation (Open or Closed)	Activating a Button (Turning it on) Will Apply +12VDC (Closed)	Activating Button (Turning it on) Opens The Circuit (Off/Not Connected)	17
Push Button State at Power Up	PB5 On (if enabled by DIP switch 9)	Any Can Be On at Power Up	
Button Operation (Latched or Momentary)	All are Standard On/Off (Latched)	Any Can Be Momentary	
Auto Beep When Any Function Active	Disabled	Beeps Every 10 sec.	18
WARN Pattern Excluded From TD Pattern Cycle Button	WARN Pattern Included	No WARN Pattern in TD Cycle	
Gun Lock Timer Button Assignment	Button PB14	None, PB1, PB2, PB3, PB4, PB5, PB13	19
Gun Lock Timer Period	10 Seconds	20 Seconds	
Gun Lock Pass Code Enable	No Passcode Needed	Passcode Need to Unlock Gun	20
Setting the Gun Lock Pass Code	PB1, PB3, PB5	Any Buttons (PB1-PB5)	
Radio/PA Speaker Diagnostic POP	Radio and PA send POP signal	No POP	21
Steady or Flashing/Pulsed Outputs	All Steady Output	Any Can Be Pulsed	
Pulsed Output Rate	Slow	Fast	22
Pulsed Output Phase	All Buttons Phase 1	Any Button(s) Phase 2	
Manual "Step Up" Function Time Out	Never Times Out	Times Out After 15 sec.	
Manual Wind Down Function	MAN Tone Winds Down When MAN Button Released	MAN Tone Stops Immediately When MAN Button Released	23
Siren Disable—Only PA & Air Horn Function	Siren Enabled	Siren Disabled	
Audio Lockout	Disabled	All Audio Functions Locked Out Until Button(s) or Slide Switch Programmed	24
Audio Lockout Unless Select	If Enabled, Slide Positions 1, 2, and 3	Any Output(s)	
Audio Pursuit Options	WAIL in Slide Position 3	Any Tone In Any SS Position or Any PB	25
Audio Pursuit Mode (HF or WAIL)	WAIL mode activated in pursuit	HF mode activated in pursuit	
HF Mode at Boot	No Mode Active at Power Up	Siren In HF Mode at Power Up	26
Quick Shot Tone Replaces Air Horn	Air Horn	Quick Shot Tone When Air Horn Pressed	
Second Tone Swap in Magnum Mode	2nd Tone of Magnum Mode Stepped Up in SS3	2nd Tone of Magnum Mode Staggered Clone of First Tone in SS3	27
Tones Sweep Disable in HF for Slide Switch Position 3	Tones Sweep in HF Mode and SS3 if Sweep Feature Enabled by DIP	Tones Do Not Sweep in HF Mode and SS 3	28
High-Low Override of Phaser Tone	Phaser Tone When PHSR Button Pressed	High-Low Tone When PHSR Button Pressed	
Horn Ring Transfer Active Mode	Always Active - Vehicle Horn (HRT) Will Always Control Siren	Vehicle Horn (HRT) Will Only Control Siren If Programmed Button(s) are ON or Slide Switch is in Programmed Position(s)	29
Button(s) or Slide Switch Required For HRT to Activate	If Enabled, SS1, SS2, and SS3	Add Any Button(s) or Remove Any Slide Switch Positions	
Slide Switch Programming (if enabled)	None	Any Button or SS output Can Be Activated By Any SS Position	30
Slide Switch Options Auto-Off	Enabled	Disabled	
Traffic Director Visual Pursuit Option	TD WARN Auto-Activates in SS3	Enable or Disable Any Positions	31
Logic Controlled TD Output Select	3-Wire LOGIC + Power	3-Wire Independent or 2-Wire+Power	
TD Logic Polarity	Positive Switching	Negative Switching	32
Function When Ground Applied to Optional Input 1	Dim Backlighting	Gun Lock	
Function When +12VDC Applied to Optional Input 2	Gun Lock	Dim Backlighting	33
Park-Kill De-activation Of Lights	Park-Kill only Disables Siren	Park-Kill Disables Both Siren AND any selected outputs	34
Reset To Defaults	Disabled	Reset Siren to Factory Default Settings	

SLIDE SWITCH OR SS POSITION #	AUDIO MODE BUTTON	PUSH BUTTON	DEFAULT SETTING	FUNCTION DEFINITION	MAN	HORN	PB1	PB2	PB3	PB4	PB5	PB13	PB14
OFF	HF	ALL PB	ONLY PB4	<b>Gun Lock Buttons</b>			PB1	PB2	PB3	PB4	PB5	PB13	PB14
OFF	WAIL	ALL PB	ALL OPEN	<b>Button Operation (Open or Closed)</b>			PB1	PB2	PB3	PB4	PB5	PB13	PB14
OFF	YELP	ALL PB	ALL STEADY	<b>Steady or Flashing/Pulsed Outputs</b>			PB1	PB2	PB3	PB4	PB5	PB13	PB14
OFF	PHASER	ALL PB	ALL LATCHED	<b>Button Operation (Momentary or Latched)</b>			PB1	PB2	PB3	PB4	PB5	PB13	PB14
OFF	RADIO	ALL PB	ALL OFF	<b>Button State at Power Up</b>			PB1	PB2	PB3	PB4	PB5	PB13	PB14
OFF	OFF	PB1	SLOW	<b>Pulsed Output Rate</b>			PB1						
OFF	OFF	PB2	DISABLED	<b>Manual "Step Up" Function 15-Sec. Time Out</b>				PB2					
OFF	OFF	PB3	ENABLED	<b>Radio and PA Test "POP"</b>					PB2				
OFF	OFF	PB4	SIREN ENABLED	<b>Siren Disable (Only PA &amp; Horn Functions)</b>						PB4			
OFF	OFF	PB5	DISABLED	<b>Auto Beep When Any Function Active</b>							PB5		
OFF	OFF	PB13	ENABLED	<b>Second Tone Swap in Magnum Mode &amp; SS③</b>								PB13	
OFF	OFF	PB14	ENABLED	<b>Tone Sweep Disable in HF for SS③</b>									PB14
①	HF	ANY PB OR SS	NONE	<b>Slide Switch ① Auto-Activates any Output</b>	②	③	PB1	PB2	PB3	PB4	PB5	PB13	PB14
①	WAIL	ANY PB OR SS	NONE	<b>Park-Kill Deactivation of Functions</b>	①&②	③	PB1	PB2	PB3	PB4	PB5	PB13	PB14
①	YELP	ANY PB	ALL PHASE 1	<b>Pulsed Output Phase (if activated by OFF-YELP)</b>			PB1	PB2	PB3	PB4	PB5	PB13	PB14
①	PHASER	PB1-PB5	1, 3, 5	<b>Set Pass Code For Gun Lock Release</b>			PB1	PB2	PB3	PB4	PB5		
①	OFF	MAN	WARN INCLUDED	<b>Remove Warn Pattern From TD Cycling</b>	MAN								
①	OFF	PB1	10 SEC.	<b>Gun Lock Timer (10 seconds or 20 seconds)</b>			PB1						
①	OFF	PB2	ENABLED	<b>Slide Switch Options Auto-Off</b>				PB2					
①	OFF	PB3	AIR HORN	<b>Quick Shot Tone Replaces Air Horn</b>					PB3				
①	OFF	PB4	POSITIVE	<b>Positive or Negative Switched LOGIC Arrowstick</b>						PB4			
①	OFF	PB5	OFF	<b>ALT TD Config 1 - L,R,&amp;W (CO= L&amp;R) Toggles with PB13 &amp; PB14</b>							PB5		
①	OFF	PB13	ON	<b>Default TD Configuration: DL15-30W-CO,L,&amp;R (Power On=Warn) Toggles with PB5 &amp; PB14</b>								PB13	
①	OFF	PB14	OFF	<b>ALT TD Config 2 - L,R, (Power On=CO) Toggles with PB5 &amp; PB13</b>									PB14
②	HF	ANY PB OR SS	NONE	<b>Slide Switch ② Auto-Activates Outputs</b>	①	③	PB1	PB2	PB3	PB4	PB5	PB13	PB14
②	WAIL	ANY PB OR SS	NONE	<b>Button(s) or SS Required for HRT Activation</b>	①&②	③	PB1	PB2	PB3	PB4	PB5	PB13	PB14
②	YELP	ANY PB OR SS	NONE	<b>Audio Lockout Unless... (Only if ENABLED by OFF-RAD-PB14)</b>	①&②	③	PB1	PB2	PB3	PB4	PB5	PB13	PB14
②	PHASER	PB1-PB3	SS③ ONLY	<b>SS Positions for Auto-Activation of WARN Patt.</b>					①	②	③		
②	RADIO	HORN/MAN	N/A	<b>Reset Siren To Factory Defaults</b>	BOTH	BOTH							
②	OFF	PB1	DISABLED	<b>High-Low Override of Phaser Tone</b>			PB1						
②	OFF	PB2	DISABLED	<b>Wind Down MAN Tone In HF Mode</b>				PB2					
②	OFF	PB3	ALWAYS ON	<b>HRT Active Mode (Configure w/SS②-WAIL)</b>					PB3				
②	OFF	PB4	DISABLED	<b>Audio Lockout (Config w/SS②-YELP)</b>						PB4			
②	OFF	PB5	DISABLED	<b>Gun Lock Release Pass Code Required</b>							PB5		
②	OFF	PB13	DISABLED	<b>HF Audio Mode at Boot</b>								PB13	
②	OFF	PB14	WAIL	<b>Audio Pursuit = WAIL or HF</b>									PB14
③	HF	ANY PB OR SS	NONE	<b>Slide Switch ③ Auto-Activates Outputs</b>	①	②	PB1	PB2	PB3	PB4	PB5	PB13	PB14
③	WAIL	ANY PB OR SS	SS③	<b>Auto-Activation of Siren in WAIL Tone</b>	①&②	③	PB1	PB2	PB3	PB4	PB5	PB13	PB14
③	YELP	ANY PB OR SS	NONE	<b>Auto-Activation of Siren in YELP Tone</b>	①&②	③	PB1	PB2	PB3	PB4	PB5	PB13	PB14
③	PHASER	ANY PB OR SS	NONE	<b>Auto-Activation of Siren in PHASER Tone</b>	①&②	③	PB1	PB2	PB3	PB4	PB5	PB13	PB14
③	OFF	PB5	ENABLED	<b>Ground Optional Input 2 to Dim Backlighting</b>							PB5		
③	OFF	PB13	DISABLED	<b>+12VDC to Optional Input 1 to Dim Backlighting</b>								PB13	
③	OFF	PB14	DISABLED	<b>Ground Optional Input 2 to Enable Gun Lock</b>									PB14
③	OFF	MAN	ENABLED	<b>+12VDC to Optional Input 1 to Enable Gun Lock</b>	MAN								

For quick reference later, we recommend highlighting any of the optional settings you have programmed.

Button Controls This Function  
 Button Controls Different Function  
 Button Does Nothing

**Detailed Programming Instructions**

The following section gives a detailed description of how to program each of the options listed on the previous two pages. **If you do not need to change any of these options, you may skip to the Mounting section on page 35.**

**WARNING!** Once you have programmed all necessary options, ***you must*** flip the Programming Mode DIP switch down to save the changes.

**PROG. MODE (Programming Mode)**

To access the additional “programmable” options described in this **Detailed Programming** section on pages 17-34, you must place the unit into “Programming Mode”:

Locate the DIP switches on the back of the Control Head.

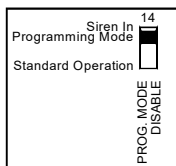
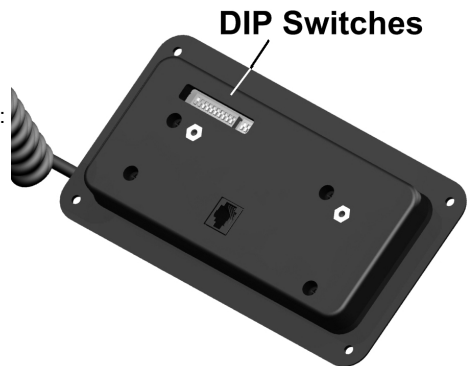
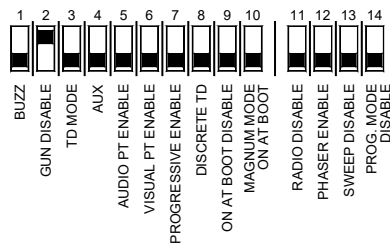

*Flip DIP switch 14 up, placing the unit into Programming Mode.*

*Program any of the options listed in this section that you need.*

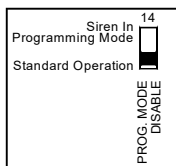

*After programming the siren, return the switch to the Standard Operation location to “SAVE” the programming.*

**NOTE :** The siren **WILL NOT** operate while in Programming Mode. DIP switch 14 must be in the “down” position for proper operation of the siren.

**WARNING!** Once you have programmed all necessary options, ***you must*** flip the Programming Mode DIP switch down to save the changes.

**All of the options on pages 17-24 can optionally be programmed using free software and a USB to serial cable (PIN SUSB-350MG) available upon request from StarSignal at 585-226-9767.**

## Button Operation (Open or Closed)

All of the Push Buttons (**PB1-PB5, PB13, PB14**), by default, operate as standard switches (“normally open”). Pressing each button once will turn them ON and “close” the connection (applies +12VDC to the corresponding output). Pressing each button again will turn them OFF and open the connection again.



If you would like any of these switches to be normally “closed” (outputting +12VDC) when they are OFF (Green) and “open” when they are ON (Red), change this setting.

Programming Mode DIP switch:	<b>Up</b>
Slide Switch:	<b>Off</b>
Activate this button (RED):	<b>WAIL</b>
Modify any of these buttons:	<b>PB1-PB5, PB13, PB14</b>

Button is **Green**: (Default setting for all buttons) When any of these buttons are activated (or ON), the circuit is “closed” or “connected” to +12VDC.

Button is **Red**: The circuit is “open” (or OFF) when ON and “closed” (or ON/connected to +12VDC) when OFF.

Each button (**PB1-PB5, PB13, PB14**) can be programmed independently of the others.



**Once you have programmed all necessary options, you must flip the Programming Mode DIP switch down to save the changes.**

## Push Button State At Power Up

**Please Note:** You must have control head DIP switch 9 (On at Boot Disable) up (Off) to use this feature (see page 7).

If you would like any of the pushbutton switches to automatically be in the ON position (activated) when the unit is powered up, change this setting:

Programming Mode DIP switch:	<b>Up</b>
Slide Switch:	<b>Off</b>
Activate this button (RED):	<b>RADIO</b>
And modify any of these buttons:	<b>PB1-PB5, PB13, PB14</b>

Button is **Green**: (Default setting for all but **PB5**) When the unit is powered up, these buttons will be OFF.

Button is **Red**: (Default setting for ONLY **PB5**) When the unit is powered up, these buttons will be ON.

**Please note:** The switches still function normally as an On/Off switch in either mode. This option only changes whether the switch is automatically On or automatically Off when the unit is powered up.



**Once you have programmed all necessary options, you must flip the Programming Mode DIP switch down to save the changes.**

## Button Operation (Latched or Momentary)

If you would like any of the buttons to act as a “momentary” pushbutton switch instead (ON only while held in), change this setting.

Programming Mode DIP switch :	<b>Up</b>
Slide Switch:	<b>Off</b>
Activate this button (RED):	<b>PHSR</b>
And modify any of these buttons:	<b>PB1-PB5, PB13, PB14</b>

Button is **Green**: (Default setting) Button operates as a standard ON/OFF button.

Button is **Red**: The button will operate as a momentary switch.

Each button (**PB1-PB5, PB13, PB14**) can be programmed independently of the others.



**Once you have programmed all necessary options, *you must* flip the Programming Mode DIP switch down to save the changes.**

## Auto Beep When Any Function Is Active

**Please Note:** You must have the BUZZ DIP switch (#1) on to use this feature (see page 5).

This feature is designed to alert the user that devices which may not be noticed by the user, are still active. If you would like the unit to beep every 10 seconds when any function is active, change this setting.

Programming Mode DIP switch:	<b>Up</b>
Slide Switch:	<b>OFF</b>
Audio Mode Buttons (HF/WAIL/YELP/PHSR/RADIO):	<b>All OFF/Green</b>
And modify this button:	<b>PB5</b>

**PB5 is Green**: (Default setting) No Auto-Beep.

**PB5 is Red**: Unit Beeps every 10 seconds whenever any functions are activated.



**Once you have programmed all necessary options, *you must* flip the Programming Mode DIP switch down to save the changes.**

## WARN Pattern Excluded From TD Pattern Cycle

**Please Note:** You must have the TD MODE DIP switch (#3) set to use the Traffic Director in order to use this feature (see pg. 5).

When using the TD CYCLE button (**PB13**) to scroll through the traffic directing patterns, the patterns will cycle from WARN►LEFT►RIGHT►CENTER OUT►OFF and repeat. If you desire to remove the WARN pattern from the cycle, change this setting.

Programming Mode DIP switch:	<b>Up</b>
Slide Switch:	<b>①</b>
Audio Mode Buttons (HF/WAIL/YELP/PHSR/RADIO):	<b>All OFF/Green</b>
And modify this button:	<b>MAN</b>



**MAN is Green**: (Default setting) WARN is included in TD cycle.

**MAN is Red**: TD button will cycle only LEFT►RIGHT►CENTER OUT►OFF and repeat.



**Once you have programmed all necessary options, *you must* flip the Programming Mode DIP switch down to save the changes.**

**All of the options on pages 17-24 can optionally be programmed using free software and a USB to serial cable (PIN SUSB-350MG) available upon request from StarSignal at 585-226-9767.**

- By default, the Gun Lock Disable DIP switch (#2) on the back of the Control Head is OFF (see page 5), enabling the basic Gun Lock option for button PB14. You MUST have this switch OFF to use these features.
- The Gun Lock options described on pages 19-21 are for advanced Gun Lock programming and are not required for basic Gun Lock operation.

### Optional Gun Lock Timer Button Assignment

If you have enabled the Gun Lock option as described on page 5, by default **PB14** will act as a timed “Gun Lock” pushbutton switch instead (timed ON to disengage your gun lock).

If you would like to use a different button and its corresponding output, or program additional buttons/outputs as Gun Lock or “timed ON” buttons, change this setting:



Programming Mode DIP switch:	<b>Up</b>
Slide Switch:	<b>Off</b>
Activate this button (RED):	<b>HF</b>
And modify any of these buttons:	<b>PB1-PB5, PB13, PB14</b>

Button is **Green**: (Default setting for **PB1-PB5, PB13**) Button operates as a standard ON/OFF pushbutton switch.

Button is **Red**: (Default setting for **PB14**) The button will now operate as a timed “Gun Lock” switch.

Each button (**PB1-PB5, PB13, PB14**) can be programmed independently of the others.



**Once you have programmed all necessary options, you must flip the Programming Mode DIP switch down to save the changes.**

### Gun Lock Timer Period (10 seconds or 20 seconds)

If you have set one or more of your push buttons to operate as a Gun Lock button above, it will default to a 10 second timed switch.

If you would like the timed switch to activate for 20 seconds instead of 10 seconds, change this setting.

Programming Mode DIP switch:	<b>Up</b>
Slide Switch:	<b>Ⓚ</b>
Audio Mode Buttons (HF/WAIL/YELP/PHSR/RADIO):	<b>All OFF/Green</b>
And modify this button:	<b>PB1</b>

**PB1 is Green**: (Default setting) All Gun Lock buttons are activated for 10 seconds.

**PB1 is Red**: All Gun Lock buttons are activated for 20 seconds.



**Once you have programmed all necessary options, you must flip the Programming Mode DIP switch down to save the changes.**

**All of the options on pages 17-24 can optionally be programmed using free software and a USB to serial cable (PIN SUSB-850MG) available upon request from StarSignal at 585-226-9767.**

## Gun Lock Button Pass Code Enable

This feature can ONLY be used if your Gun Lock release button is **PB14**.

Normally the Gun Lock can be operated by simply pressing the appropriate Gun Lock button. If you require a higher level of security, you can require a Pass Code to be entered to release the Gun Lock (**PB14 only**).

To require that the pass code, change this setting:

Programming Mode DIP switch:	<b>Up</b>
Slide Switch:	<b>ⓐ</b>
Modify this button:	<b>PB5</b>

Button is **Green**: (Default setting) No Pass Code required to release Gun Lock.

Button is **Red**: Pass Code required to release Gun Lock.

Under normal operation, if you have the Pass Code option enabled, when the **PB14** Gun Lock button is pressed:

- The Gun Lock button will turn a flickering red/green.
- Buttons **PB1-PB5** will all turn green.
- The siren and lighting functions selected before the Gun Lock button was pressed will remain active but unable to be changed until the Gun Lock pass code entry is complete.

### Default Pass Code

<b>PB1</b>	ON	Red
<b>PB2</b>	OFF	Green
<b>PB3</b>	ON	Red
<b>PB4</b>	OFF	Green
<b>PB5</b>	ON	Red



To release the Gun Lock:

- While the Gun Lock button is flickering Red/Green, press the appropriate buttons (**P1-P5**). ONLY the designated buttons can be "ON" (RED). The default pass code is buttons 1, 3, and 5 ON/RED and buttons 2 and 4 OFF/GREEN.
- Then press the Gun Lock button again (or wait 10 seconds until time out occurs).
- If the correct pass code was entered (correct buttons are RED) the Gun Lock will temporarily release and the other functions on the siren will be editable once again.
- If the incorrect password was entered, the siren will beep 5 times quickly and the Gun Lock WILL NOT be released.

**WARNING!** Once you have programmed all necessary options, you must flip the Programming Mode DIP switch down to save the changes.

**All of the options on pages 17-24 can optionally be programmed using free software and a USB to serial cable (PIN SUS8-850MG) available upon request from StarSignal at 585-226-9767.**

## Setting the Gun Lock Pass Code

Before proceeding please verify the following:

- You have the Gun Lock Disable DIP Switch OFF (see page 5)
- Only **PB14** is set as a Gun Lock button
- You have enabled the Gun Lock Pass Code (see previous page)

When you enable the Gun Lock Pass Code (described on the previous page), the default pass code is:

- \* **PB1, PB3, and PB5 ON**
- \* **PB2 and PB4 OFF**

To select a different pass code:

Programming Mode DIP switch: **Up**  
 Slide Switch: **⊕**  
 Activate this button (RED): **PHASER**  
 And modify any of these buttons: **PB1-PB5**



Button is **Red**: (Default setting for **PB1, PB3, PB5**) Must activate this button (and any other Red buttons) after the Gun Lock button is pressed to release Gun Lock.

Button is **Green**: (Default setting for **PB2, PB4**) This button (and any other Green buttons) **MUST NOT** be activated after the Gun Lock button is pressed

 **Once you have programmed all necessary options, *you must* flip the Programming Mode DIP switch down to save the changes.**

## Disabling Radio/PA Diagnostic POP

As a standard feature the Radio and PA tones create a “POP” the first time they are powered up from the off state. This feature is enabled to detect for shorts in the speakers and/or speaker wiring. In the event of a short, the unit will not activate these modes, thus preventing possible damage to the unit itself (specifically the output transistors).

Although the siren has been designed so that this feature can be disabled, **DISABLING THIS FEATURE WILL VOID THE WARRANTY ON THE OUTPUT TRANSISTORS AND FOR ANY OTHER ISSUES DETERMINED TO BE DIRECTLY RELATED TO A SHORT IN THE SPEAKER AND/OR SPEAKER WIRING.**

If you wish to disable this feature, change this setting:

Programming Mode DIP switch: **Up**  
 Slide Switch: **OFF**  
 Audio Mode Buttons (HF/WAIL/YELP/PHSR/RADIO): **All OFF/Green**  
 And modify this button: **PB3**

**PB3 is Green**: (Default setting) Diagnostic POP active.

**PB3 is Red**: Diagnostic POP disabled (warranty void).

 **Once you have programmed all necessary options, *you must* flip the Programming Mode DIP switch down to save the changes.**



### Steady or Flashing/Pulsed Outputs

The outputs switched by each push button normally apply steady +12 VDC.

If you would like any of these outputs to be flashing or pulsed (i.e. if you were hooking it up to a light that didn't have its own flasher), change this setting.

Programming Mode DIP Switch:	<b>Up</b>
Slide Switch:	<b>Off</b>
Activate this button (RED):	<b>YELP</b>
And modify any of these buttons:	<b>PB1-PB5, PB13, PB14</b>

Button is **Green**: (Default setting) The output will deliver steady +12 VDC.

Button is **Red**: The output will pulse +12 VDC.

Each button (**PB1-PB5, PB13, PB14**) can be programmed independently of the others. The buttons that control any outputs programmed to flash, will flash green to indicate they are a "pulsed" output.



**Once you have programmed all necessary options, you must flip the Programming Mode DIP switch down to save the changes.**

### Pulsed Output Rate

If you have set any of the outputs to pulse (as described above), they will default to a slow flashing pattern. If you would like your pulsed outputs to use a fast flashing pattern, change this setting. All pulsed outputs must be slow or all pulsed outputs must be fast. You cannot program the pulse speed of each output independently.

Programming Mode DIP Switch:	<b>Up</b>
Slide Switch:	<b>OFF</b>
Audio Mode Buttons (HF/WAIL/YELP/PHSR/RADIO):	<b>All OFF/Green</b>
And modify this button:	<b>PB1</b>

Button is **Green**: (Default setting) ALL pulsed outputs will flash slow.

Button is **Red**: ALL pulsed outputs will flash fast.



**Once you have programmed all necessary options, you must flip the Programming Mode DIP switch down to save the changes.**

### Pulsed Output Phase (for use with two or more pulsed outputs)

If you have set any of the outputs to pulse (as described above), there are two "phases" each can flash in (Phase 1 alternates with Phase 2). By default, all of the outputs are set for Phase 1 (they will all flash "On" at the same time). If you wish any of the outputs to flash in Phase 2 (opposite Phase 1), change this setting.

Programming Mode DIP Switch:	<b>Up</b>
Slide Switch:	<b>①</b>
Activate this button (RED):	<b>YELP</b>
And modify any of these buttons:	<b>PB1-PB5, PB13, PB14</b>

Button is **Green**: (Default setting) Output, if pulsed, will flash during Phase 1.

Button is **Red**: Output, if pulsed, will flash during Phase 2.



**Once you have programmed all necessary options, you must flip the Programming Mode DIP switch down to save the changes.**

Advanced Pulsed Output Programming

**All of the options on pages 17-24 can optionally be programmed using free software and a USB to serial cable (PIN SUSB-350MG) available upon request from StarSignal at 585-226-9767.**

## Manual “Step-Up” Function Time Out

Normally when a siren tone is activated by pressing the WAIL, YELP, or PHSR buttons, pressing the MAN button will advance (or “Step-Up”) one of the tones to the next siren tone, where it will remain until you deactivate it by pressing the MAN button again or activating a different Audio Mode.

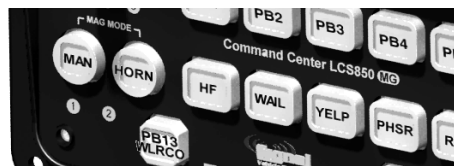

If you would like the Manual button only to *temporarily* step up the tone for 15 seconds and then revert back to the original tone, change this setting.

Programming Mode DIP Switch:	<b>Up</b>
Slide Switch:	<b>OFF</b>
Audio Mode Buttons (HF/WAIL/YELP/PHSR/RADIO):	<b>All OFF/Green</b>
And modify this button:	<b>PB2</b>

If **PB2** is **Green**: (Default setting) Manual button tone change remains stepped up.

If **PB2** is **Red**: Manual button tone step up time out after 15 seconds tone.

**Please Note:** The MAN button will have no effect if the siren is in HF mode and a tone has been activated by the AUX wire/HRT.



**Once you have programmed all necessary options, you must flip the Programming Mode DIP switch down to save the changes.**

## Manual “Wind Down” Function In Standby or Hands Free Mode (HF)

Normally when the siren is in Standby or Hands Free Mode (HF) and no tone is being produced, pressing the MAN button will produce tone that “winds up”. When the button is released, the siren will “wind down”.

If you would instead like the tone to immediately silence when released (rather than winding down), change this setting.

Programming Mode DIP Switch:	<b>Up</b>
Slide Switch:	<b>②</b>
Audio Mode Buttons (HF/WAIL/YELP/PHSR/RADIO):	<b>All OFF/Green</b>
And modify this button:	<b>PB2</b>

If **PB2** is **Red**: (Default setting) Releasing the MAN button will “wind down” the siren.

If **PB2** is **Green**: Releasing the MAN button will immediately silence the siren.

**Please Note:** The MAN button will have no effect if the siren is in HF mode and a tone has been activated by the AUX wire/HRT.



**Once you have programmed all necessary options, you must flip the Programming Mode DIP switch down to save the changes.**

**Siren Disable (PA and Horn Functions only)**

If you desire to COMPLETELY disable the siren feature from this unit, allowing **only** the PA, Horn, and Radio audio functions (applications such as security, volunteer, training etc.), change this setting.



Mode DIP switch is in this position: **Up**  
Slide Switch: **OFF**  
Audio Mode Buttons: **All OFF/Green**  
And modify this button: **PB4**

**PB4 is Green:** (Default setting) Siren functions normally.

**PB4 is Red:** Siren tones WILL NOT function in any mode.

 **Once you have programmed all necessary options, you must flip the Programming Mode DIP switch down to save the changes.**

**Audio Lockout Enable**

Normally, you can activate the siren at any time, by pressing any of the Siren Audio Mode buttons (WAIL, YELP, PHSR). If you would like to prevent the siren from activating UNTIL a certain push button is activated, or the slide switch is moved, change this setting.

Programming Mode DIP Switch: **Up**  
Slide Switch: **②**  
Audio Mode Buttons (HF/WAIL/YELP/PHSR/RADIO): **All OFF/Green**  
And modify this button: **PB4**

If **PB4 is Green:** (Default setting) Siren function always available.

If **PB4 is Red:** Siren will only operate if any of the buttons or slide switch programmed below are activated. (By default, any Slide position other than off will allow for operation of the siren.)

 **Once you have programmed all necessary options, you must flip the Programming Mode DIP switch down to save the changes.**

**Audio Lockout "Unless" Select (Buttons/Slide Positions That Disable Audio Lockout)**

The Audio Lockout feature MUST be enabled as described above in addition to programming the "Lockout Disable Buttons" described below.

By default, if you have Audio Lockout enabled, the siren tones will not activate unless you have the slide switch in positions ①, ②, or ③. If you wish to change the "Lockout Disable Buttons", follow the steps below to select or deselect the desired button(s) and/or slide position(s) that will permit Audio functions.

Programming Mode DIP Switch: **Up**  
Slide Switch: **②**  
Activate this button (RED): **YELP**  
And modify any of these buttons: **PB1-PB5, PB13, PB14, MAN, HORN**  
(Use the MAN button to program for slide position 3 and use the HORN button for slide position 1 & 2)

If Button is **Red:** (Default setting for HORN & MAN) That button or slide position will disable the Audio Lockout feature and allow the siren to operate.

If Button is **Green:** (Default for PB1-PB14) Button/slide position has no effect on Audio Lockout.

 **Once you have programmed all necessary options, you must flip the Programming Mode DIP switch down to save the changes.**

▷ —Advanced Audio Lockout Programming— ◁

**All of the options on pages 17-24 can optionally be programmed using free software and a USB to serial cable (PIN SUSB-350MG) available upon request from StarSignal at 585-226-9767.**

### Audio Pursuit Options

By default, Slide Switch ③ will automatically activate your siren in WAIL mode (unless you have disabled it using Control Head DIP switch 5/Audio Pursuit as described on page 6).

Optionally, you can choose any of the siren tones (WAIL, YELP, PHASER) to activate in any of the slide switch positions or to activate when any of the pushbuttons are activated (**PB1-PB5**, **PB13**, or **PB14**).



If you would like to add or remove slide positions or push buttons that auto-activate the various tones, change this setting.

<i>To Set Auto-Activation</i>			
<i>for Each of These Siren Tones:</i>			
	WAIL	YELP	PHASER
Programming Mode DIP Switch:	<b>Up</b>	<b>Up</b>	<b>Up</b>
Slide Switch:	③	③	③
Activate this button (RED):	<b>WAIL</b>	<b>YELP</b>	<b>PHASER</b>
And modify any of these buttons:	<b>PB1-PB5, PB13, PB14, MAN, HORN</b>		

- Program each siren tone separately.
- Verify the Programming DIP switch is Up.
- Place the Slide Switch in position ③.
- Press the Audio Mode button for the tone that you wish to program (WAIL, YELP, or PHASER).
- Toggle the various buttons listed above to have the siren tone you are programming for auto-activate when you press that button or move the slide switch into that position.

If button is **Green**: This button or slide switch position WILL NOT activate the tone you are programming for. (Default setting for all buttons except MAN when programming for WAIL tone)

If button **PB1-PB5**, **PB13**, or **PB14** is **Red**: The siren tone you are programming for WILL auto-activate when that button is pressed.

If **MAN** button is **Red** : The siren tone you are programming for WILL auto-activate when the slide switch is in ③.

If **HORN** button is **Red** : The siren tone you are programming for WILL auto-activate when the slide switch is in ① or ②.

*Please Note:* If you have more than one tone programmed for a particular position or button, only the fastest tone will be produced (i.e. PHASER overrides YELP, which overrides WAIL).

**WARNING!** Once you have programmed all necessary options, you must flip the Programming Mode DIP switch down to save the changes.

## Audio Pursuit Mode (WAIL or HF)

As indicated on the previous page, by default, Slide Switch ③ will automatically activate your siren in WAIL mode (unless you have disabled it using Control Head DIP switch 6/Audio Pursuit as described on page 6).

For some applications it may be desired that instead of the siren going directly to a wail tone, it goes into Hands Free Mode (HF) under Audio Pursuit, where the siren can be easily activated through the HRT (vehicle horn switch) when desired. Typically, when using this option, all three slide switch positions are programmed for Audio Pursuit mode (see previous page for slide switch Audio Pursuit programming). **At least one position must be already programmed for WAIL tone in Audio Pursuit for this option to work (default for SS3).**

If you would like the siren to go into HF mode instead of WAIL when in pursuit, change this setting:

Programming Mode DIP Switch:	<b>Up</b>
Slide Switch:	<b>②</b>
Audio Mode Buttons (HF/WAIL/YELP/PHSR/RADIO):	<b>All OFF/Green</b>
And modify this button:	<b>PB14</b>

**PB14 is Green:** (Default setting) When you go into pursuit mode, the siren auto-activates with the WAIL tone.

**PB14 is Red:** When you go into pursuit mode, the siren auto-activates into HF mode (unless you have enabled the SWEEP DIP switch - see page 8, and have NOT disabled Sweep for SS3—see page 28).



**Once you have programmed all necessary options, you must flip the Programming Mode DIP switch down to save the changes.**

## HF Mode at Boot

By default, when the LCS850MG unit is powered up, no Audio Mode will be selected (active).

If you would like the siren to automatically be in HF Mode (siren can be activated by AUX wire/HRT), change this setting:

Programming Mode DIP Switch:	<b>Up</b>
Slide Switch:	<b>②</b>
Audio Mode Buttons (HF/WAIL/YELP/PHSR/RADIO):	<b>All OFF/Green</b>
And modify this button:	<b>PB13</b>

If Button is **Green:** (Default setting) When the unit is powered up, no Audio Mode is active.

If Button is **Red:** When powered up, the unit will be in Hands Free Mode (HF), allowing remote activation of the siren via the HRT.



**Once you have programmed all necessary options, you must flip the Programming Mode DIP switch down to save the changes.**

## Quick Shot Tone Replaces Air Horn

The standard Air Horn tone can be replaced with an optional "Quick Shot" tone. This tone creates a quick double-burst of sound each time the Air Horn button (or vehicle horn/AUX if applicable) is pressed.

If you would like to use the Quick Shot tone instead of the Air Horn tone, change this setting:

Programming Mode DIP Switch:	<b>Up</b>
Slide Switch:	<b>①</b>
Audio Mode Buttons (HF/WAIL/YELP/PHSR/RADIO):	<b>All OFF/Green</b>
And modify this button:	<b>PB3</b>

If **PB3 is Green:** (Default setting) Air Horn tone functions normally.

If **PB3 is Red:** Air Horn tone is replaced by the Quick Shot tone.



**Once you have programmed all necessary options, you must flip the Programming Mode DIP switch down to save the changes.**

**All of the options on pages 17-24 can optionally be programmed using free software and a USB to serial cable (PIN SUSB-850MG) available upon request from StarSignal at 585-226-9767.**

**Second Tone Swap in Magnum Mode for Slide Switch ③**

This siren is equipped for Magnum Mode which allows it to drive two separate speakers with different outputs (see **Magnum Mode** on page 7 and page 48 for further details about Magnum Mode).

Normally, when you move the Slide Switch to position ③ the siren is automatically activated (audio pursuit mode). While in Magnum Mode, the second tone produced will be automatically “stepped up” from the first tone, to the next priority level (e.g. If the first tone is WAIL, the second tone will be YELP). This is different than the default Magnum Mode when the tone is activated by one of the audio buttons (WAIL, YELP, or PHASER) and the second tone is staggered.



When you activate audio pursuit, if you rather would have the second tone of the Magnum Mode be a staggered clone of the first tone, change this setting.

Programming Mode DIP Switch:	<b>Up</b>
Slide Switch:	<b>OFF</b>
Audio Mode Buttons (HF/WAIL/YELP/PHSR/RADIO):	<b>All OFF/Green</b>
And modify this button:	<b>PB13</b>

If **PB13** is **Red**: (Default setting) Second Tone Swap is active - When the slide switch is moved to position ③ and the siren is in Magnum Mode, the second tone will be a different tone than the first.

If **PB13** is **Green**: Second Tone Swap is NOT active - When the slide switch is moved to position ③ and the siren is in Magnum Mode, the second tone will be a staggered clone of the first tone.



**WARNING!** Once you have programmed all necessary options, you must flip the Programming Mode DIP switch down to save the changes.



# QUICK INSTALLATION GUIDE

## REMOVABLE CENTERFOLD

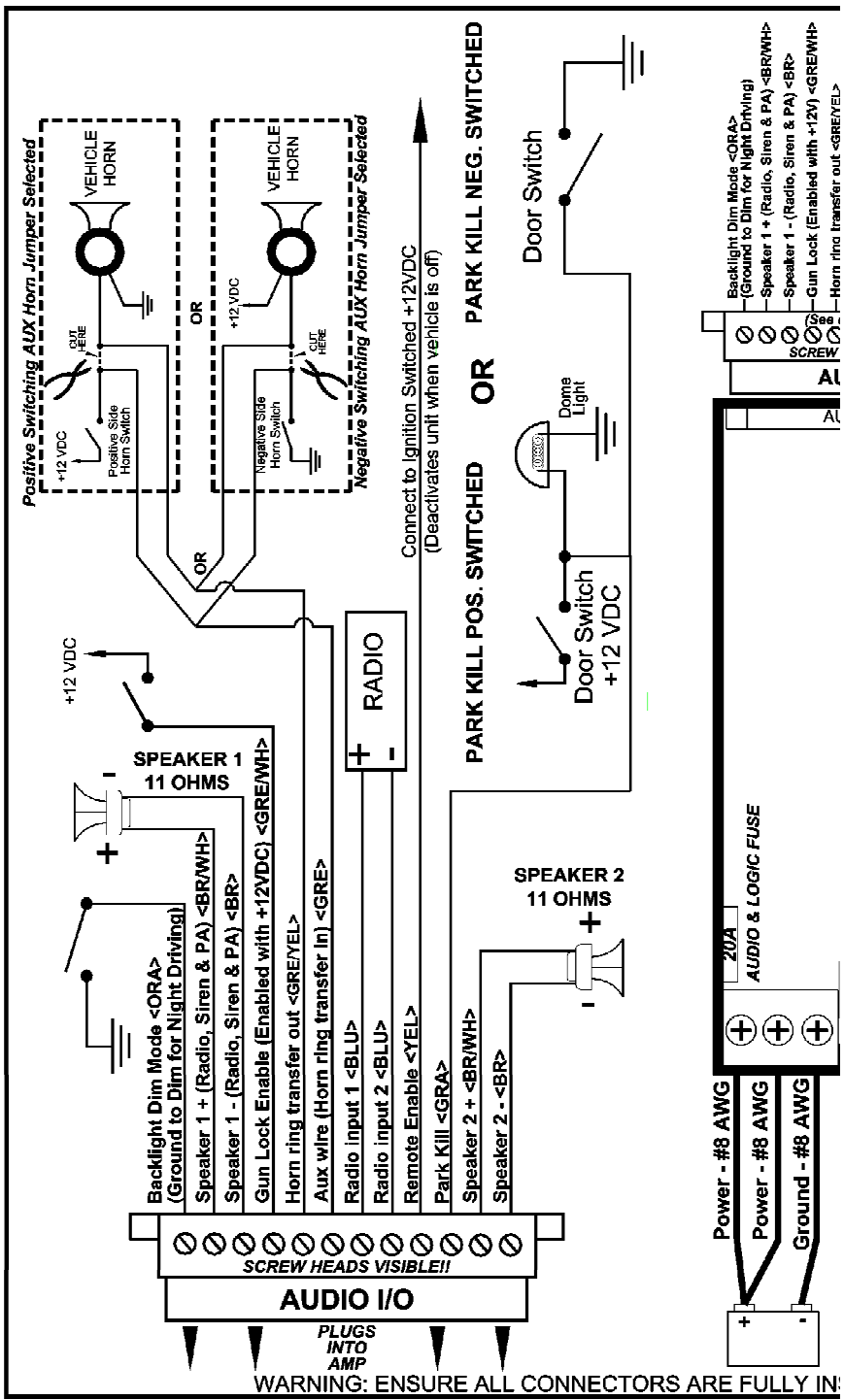



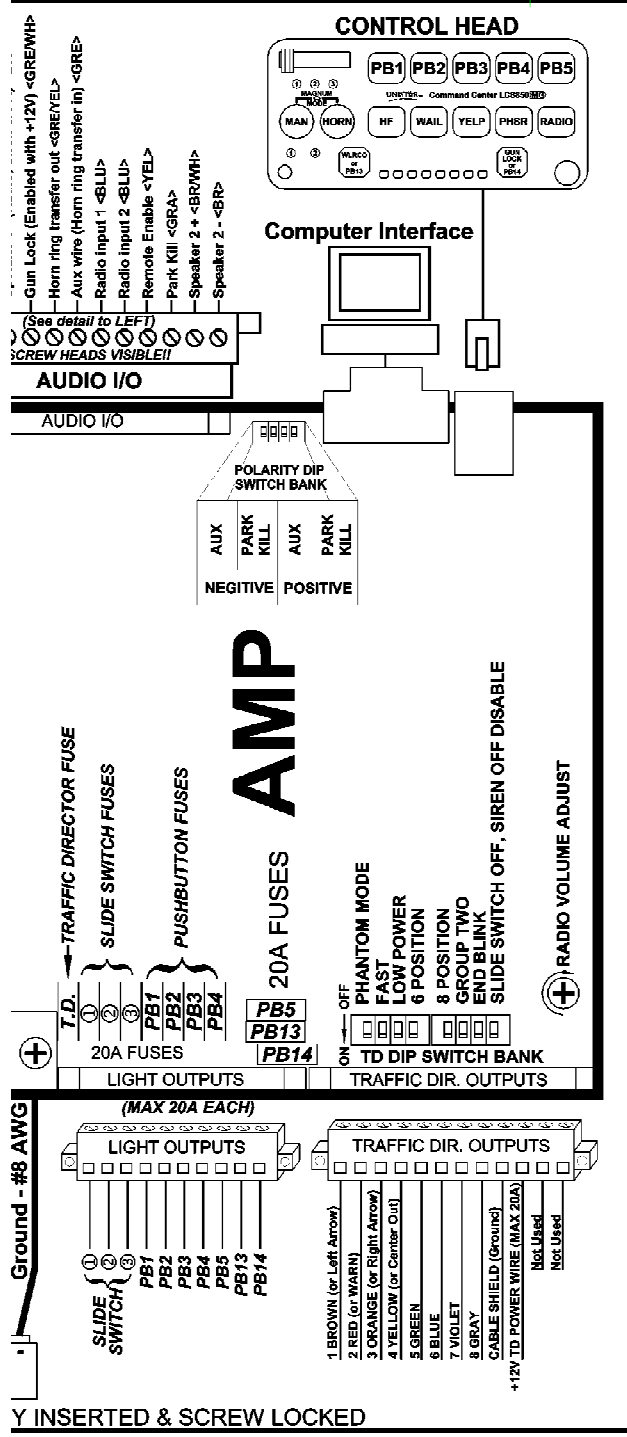

### QUICK INSTALLATION CHECKLIST

- 8 AWG Wire to Ground Terminal
- +12VDC to two Power Terminals (Use 8 AWG)
- Lights connected to PB1-PB14 outputs
- Ignition switched +12VDC to Terminal 4 of 12-way conn. (AUDIO I/O)
- Speaker (+) and (-) connected
- Correct AUX and Park-Kill polarity (+ is default)
- Gun Lock Terminal (#9 of AUDIO I/O) to +12VDC (direct or through switch, if applicable)



**All of the options on pages 17-24 can optionally be programmed using free software and a USB to serial cable (PIN SUSB-350MG) available upon request from StarSignal at 585-226-9767.**

## Tone Sweep Disable in HF for Slide Switch ③

- Review the Sweep Disable section on page 8.
- SWEEP DISABLE DIP switch **must be** set for 'Auto Tone Sweep in HF'.

If, when in HF mode, you only want the siren to automatically “sweep” through all of the other tones when the siren is activated by the AUX input/HRT, and you DO NOT want the tones to sweep when the siren is activated by Slide Switch ③, then change this setting:

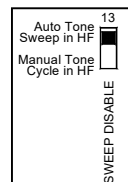

Programming Mode DIP Switch:	<b>Up</b>
Slide Switch:	<b>OFF</b>
Audio Mode Buttons (HF/WAIL/YELP/PHSR/RADIO):	<b>All OFF/Green</b>
And modify this button:	<b>PB14</b>

If **PB14** is **Red**: (Default setting) SS③ WILL activate Tone Sweep when the siren is in HF mode and the SWEEP DIP switch is up.

If **PB14** is **Green**: SS③ WILL NOT activate Tone Sweep when the siren is in HF mode and the SWEEP DIP switch is up. Only the AUX input will activate the tone sweep.

**WARNING!** Once you have programmed all necessary options, **you must flip** the Programming Mode DIP switch down to save the changes.

## High-Low (Two-Tone) Override of Phaser Tone

By default, the Phaser tone is enabled on this siren. This tone can be replaced with a High/Low siren (also known as Two Tone or the European sound), if desired. Some municipalities may have regulations regarding the use of the Phaser tone and you may wish to replace it with the High/Low tone.

If you would like to use the High/Low tone instead of the Phaser tone, change this setting.

Programming Mode DIP Switch:	<b>Up</b>
Slide Switch:	<b>②</b>
Audio Mode Buttons (HF/WAIL/YELP/PHSR/RADIO):	<b>All OFF/Green</b>
And modify this button:	<b>PB1</b>

If **PB1** is **Green**: (Default setting) Phaser tone functions normally.

If **PB1** is **Red**: Phaser tone is replaced by the High/Low tone.

**WARNING!** Once you have programmed all necessary options, **you must flip** the Programming Mode DIP switch down to save the changes.

**All of the options on pages 17-24 can optionally be programmed using free software and a USB to serial cable (PIN SUSB-850MG) available upon request from StarSignal at 585-226-9767.**

### Horn Ring Transfer (HRT) Active Mode

Normally, if you have the HRT connected you can control the siren any time it is on using the vehicle horn (switch).

If instead, you would like the ability of the vehicle horn/HRT to ONLY change the tone once the slide switch or certain buttons are activated, change this setting.

Programming Mode DIP Switch:	<b>Up</b>
Slide Switch:	<b>②</b>
Audio Mode Buttons (HF/WAIL/YELP/PHSR/RADIO):	<b>All OFF/Green</b>
And modify this button:	<b>PB3</b>

If **PB3** is **Green**: (Default setting) The HRT function will operate any time the siren is on.

If **PB3** is **Red**: The HRT feature will only operate when the buttons programmed (described below) are activated. (By default, if **PB3** is Red, the HRT function will be operational any time the Slide Switch is moved to ①, ②, or ③).

If **PB3** is **GREEN**, move to the next option or flip the PGM DIP switch down to save the changes.



If **PB3** is **RED**, you may need to proceed below to program the functions necessary for the HRT to function. If the default setting of any Slide Switch position activating HRT is acceptable, you can skip the Advanced Slide Switch Programming section below.



Once you have programmed all necessary options, **you must flip** the Programming Mode DIP switch down to save the changes.

### Advanced Horn Ring Transfer Programming

If you need to select which buttons or slide switch positions will enable functioning of the HRT mode, proceed below.

Programming Mode DIP Switch:	<b>Up</b>
Slide Switch:	<b>②</b>
Activate this button (RED):	<b>WAIL</b>
And modify these buttons:	<b>PB1-PB14, HORN, MAN</b>

**PB1-PB14** are **Red**: If any of the functions tied to each Red button (**PB1-PB14**) are activated, the HRT function is available.

**MAN** is **Red**: (Default setting) If **SS③** is activated, the HRT function is available.

**HORN** is **Red**: (Default setting) If **SS①** or **SS②** is activated, the HRT function is available.

**PB1-PB14, HORN, MAN** are **Green**: (Default for **PB1-PB5, PB13, PB14**) These buttons (**PB1-PB14**) or SS positions will have no effect on whether or not the HRT function is available.



Once you have programmed all necessary options, **you must flip** the Programming Mode DIP switch down to save the changes.

All of the options on pages 17-24 can optionally be programmed using free software and a USB to serial cable (PIN SUSB-350MG) available upon request from StarSignal at 585-226-9767.

### Slide Switch Programming

The default setting for the Progressive Enable DIP switch is for “progressive” switching (see *DIP Switch Settings on page 6*). This means that each position will add another function while keeping the previous one(s) on. Position ① activates the first function. Position ② activates the functions connected to both ① and ②. Position ③ will activate all of the functions connected to ①, ②, and ③.

To modify the functions that are activated by each slide switch position, ensure that control head DIP switch 7 up, as described on page 6.

When DIP switch 7 is up, the slide switch will operate based upon the settings you have programmed. By default the Programmable setting is for NO additional functions to be activated in each slide switch position (thus defaulting as Non-Progressive). To change the settings, proceed below:

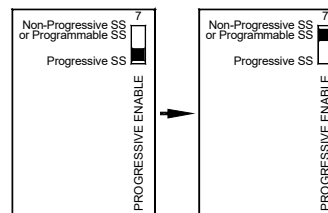

*To Program Settings for Each of These Slide Switch Positions:*

	①	②	③
Programming Mode DIP Switch:	<b>Up</b>	<b>Up</b>	<b>Up</b>
Slide Switch:	①	②	③
Activate this button (RED):	<b>HF</b>	<b>HF</b>	<b>HF</b>
And modify any of these buttons:	<b>PB1-PB5, PB13, PB14, MAN, HORN</b>		

- Program each Slide Switch position individually.
- Verify the Programming DIP switch is UP.
- Place the Slide Switch in the position you wish to program.
- Activate the HF button.
- Modify any buttons that you want to auto-activate for each slide switch position.

If button is **Green**: (Default setting for all buttons) This function WILL NOT activate in the corresponding slide switch position.

If button **PB1-PB5, PB13, or PB14** is **Red**: The function attached to each corresponding output WILL activate when the slide switch is in the position you are programming.

#### Slide Switch Outputs Represented By MAN and HORN Buttons

If This Button Is Red...	While Programming For This Slide Switch Position...		
	①	②	③
MAN	Output ③ will activate when SS in ①	Output ③ will activate when SS in ②	Output ② will activate when SS in ③
HORN	Output ② will activate when SS in ①	Output ① will activate when SS in ②	Output ① will activate when SS in ③

**Once you have programmed all necessary options, *you must* flip the Programming Mode DIP switch down to save the changes.**

**All of the options on pages 17-34 can optionally be programmed using free software and a USB to serial cable (PIN SUSB-350MG) available upon request from StarSignal at 585-226-9767.**

▽ Advanced Slide Switch Programming ▽

### Slide Switch Options Auto-Off

By default, any of the additional button functions that you have programmed (as described on the previous page) to auto-activate with the various slide switch positions, will DE-ACTIVATE once you move the Slide Switch out of the corresponding position. *(Note: This only applies to the button or slide switch outputs, it does NOT apply to the Audio Pursuit or TD Pursuit options.)*

If you want the functions to continue to stay **on**, once the slide switch is moved out of the corresponding position, change this setting.

Programming Mode DIP Switch:	<b>Up</b>
Slide Switch:	<b>①</b>
Audio Mode Buttons (HF/WAIL/YELP/PHSR/RADIO):	<b>All OFF/Green</b>
And modify this button:	<b>PB2</b>

If **PB2 is Green**: *(Default setting)* Push button functions that are auto-activated with the slide switch will turn off when the slide switch is moved out of the corresponding position.

If **PB2 is Red**: Push button functions that are auto-activated with the slide switch will stay on until the button each is associated with is pressed.

**WARNING!** Once you have programmed all necessary options, ***you must flip*** the Programming Mode DIP switch down to save the changes.

### Traffic Director Visual Pursuit

Normally, moving the slide switch to position **③** will automatically activate your traffic director in Warn mode (unless you have disabled it using Control Head DIP switch 6/Visual Pursuit as described on page 6). Optionally, you can select or deselect which slide positions will auto-activate the Traffic Director.

If you would like to add or remove slide positions that auto-activate the Traffic Director, change this setting.

Programming Mode DIP Switch:	<b>Up</b>
Slide Switch:	<b>②</b>
Activate this button (RED):	<b>PHSR</b>
And modify any of these buttons:	<b>PB1, PB2, or PB3</b>

*(Use the PB1 button to program for slide position ①, use the PB2 button to program for slide position ②, and use the PB3 button to program for slide position ③)*

Button is **Red**: *(Default setting for PB3/SS③)* The Traffic Director will automatically activate into the Warn pattern whenever the Slide Switch is in this position.

Button is **Green**: *(Default setting for PB1/SS① & PB2/SS②)* This Slide Switch position has no effect on the Traffic Director.



**WARNING!** Once you have programmed all necessary options, ***you must flip*** the Programming Mode DIP switch down to save the changes.

**All of the options on pages 17-24 can optionally be programmed using free software and a USB to serial cable (PIN SUS8-350MG) available upon request from StarSignal at 585-226-9767.**

## Logic Controlled Traffic Director Programming

The two options described below ONLY apply if you have set Control Head DIP switch #8 (DISCRETE TD) for a LOGIC controlled traffic director (see page 6). That DIP switch MUST be in the up position to use this option.

## Logic Controlled Output Select

(arrowstick) that has a built in controller (i.e. uses LOGIC controls). It can be programmed to operate sticks with three different input requirements:

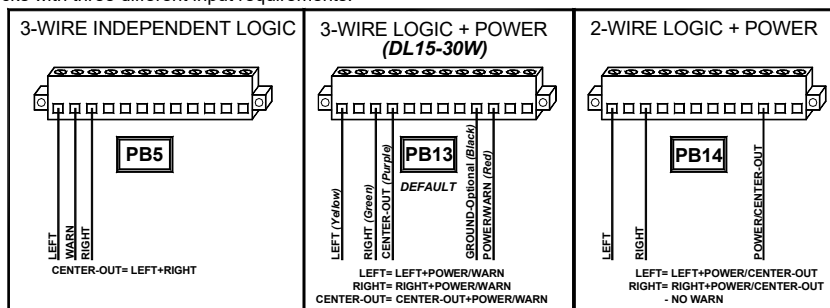

By default, when you set Control Head DIP switch #8 (DISCRETE TD) up (to use a LOGIC controlled TD), the output of the wires will control our DL15-30W (see center diagram above).

If your arrowstick operates differently, program the output as described below:

Programming Mode DIP Switch:	Up
Slide Switch:	①
Audio Mode Buttons (HF/WAIL/YELP/PHSR/RADIO):	All OFF/Green
And modify these buttons:	PB5, PB13, PB14

During programming, **PB5, PB13, PB14** buttons will operate as “radio” type buttons (only one can be active at any time). Depressing (activating) one button will change it to RED and will deactivate the other two buttons (change them to GREEN).

- PB5 is Red:** The LOGIC outputs will be set for 3-WIRE INDEPENDENT.
- PB13 is Red:** (Default setting) The LOGIC outputs will be set for 3-WIRE+POWER.
- PB14 is Red:** The LOGIC outputs will be set for 2-WIRE+POWER.

**Once you have programmed all necessary options, you must flip the Programming Mode DIP switch down to save the changes.**

## Logic Controlled Traffic Director Polarity

By default, when you select to use a LOGIC controlled TD, the output wires will output +12VDC (see *Traffic Directors with Built-In Controllers* on page 13).

If instead, you would like the outputs to be grounded, change this setting.

Programming Mode DIP Switch:	Up
Slide Switch:	①
Audio Mode Buttons (HF/WAIL/YELP/PHSR/RADIO):	All OFF/Green
And modify this button:	PB4

- PB4 is Green:** (Default setting) The LOGIC outputs described on page 13 will output +12vdc.
- PB4 is Red:** The LOGIC outputs described on page 13 will output Ground.

**Once you have programmed all necessary options, you must flip the Programming Mode DIP switch down to save the changes.**

**All of the options on pages 17-24 can optionally be programmed using free software and a USB to serial cable (PIN SUSE-850MG) available upon request from StarSignal at 585-226-9767.**

## Optional Input Functions

The LCS850MG has two optional inputs that can be used to ENABLE the Gun Lock button and control the siren faceplate backlighting:

- Input 1 (terminal 9) activates the corresponding feature when +12VDC is applied to it.
- Input 2 (terminal 12) activates the corresponding feature when Ground is applied to it.

By default, the Gun Lock button is enabled through Optional Input 1 and WILL NOT function until +12VDC is applied to it.

By default, the Backlighting Dim feature is activated through Optional Input 2. When Ground is applied to it, the Backlighting of the siren control head is dimmed for night driving.

Optionally, you can swap these inputs so that Input 1 (terminal 9) activates the backlighting dim feature and/or Input 2 (terminal 12) will allow the Gun Lock button to function.

*Note: Although not usually desired, both features can be controlled by the same wire.*

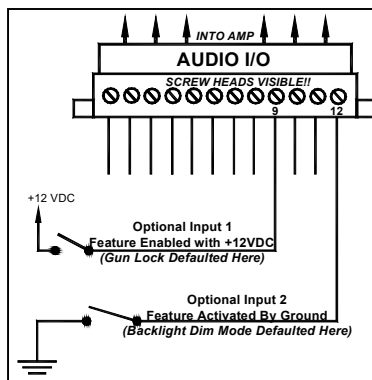

**Please note:** By default the Gun Lock button *WILL NOT* operate unless you have +12VDC applied to terminal 9 of the AUDIO I/O connector. To bypass this feature, connect Terminal 9 directly to +12VDC or Program as described below (PB14 and MAN Green)

If you DO wish to change either of these settings, proceed below.

Programming Mode DIP Switch:	<b>Up</b>
Slide Switch:	<b>③</b>
Audio Mode Buttons (HF/WAIL/YELP/PHSR/RADIO):	<b>All OFF/Green</b>
And modify these buttons:	<b>PB5, PB13, PB14, MAN</b>

**Please note:** Typically **PB5** and the **MAN** button should be the same color as each other and the opposite color of **PB13** and **PB14**.

### Backlighting Settings

Button	If Red...	If Green...
PB5	+12 VDC to Terminal 9 Will Dim Backlighting	Terminal 9 does not affect backlighting (Default Setting)
PB13	Ground To Terminal 12 Will Dim Backlighting (Default Setting)	Terminal 12 does not affect backlighting

### Gun Lock Settings

Button	If Red...	If Green...
PB14	+12 VDC to Terminal 9 Enables Gun Lock Button (Default Setting)	Terminal 9 does not affect Gun Lock Button
MAN	Ground To Terminal 12 Enables Gun Lock Button	Terminal 12 does not affect Gun Lock Button (Default Setting)

**WARNING!** Once you have programmed all necessary options, *you must* flip the Programming Mode DIP switch down to save the changes.



**All of the options on pages 17-24 can optionally be programmed using free software and a USB to serial cable (PIN SUSB-350MG) available upon request from StarSignal at 585-226-9767.**

## Park-Kill De-activation of Lights

The Park-Kill option automatically shuts off the siren when activated.  
(see Page 43 - Terminal 3)

If you would also like it to automatically disable any of the outputs tied to your Slide Switch or Push Buttons, change these settings.

Programming Mode DIP Switch:	<b>Up</b>
Slide Switch:	<b>①</b>
Activate this button (RED):	<b>WAIL</b>
And modify these buttons:	<b>PB1-PB5, PB13, PB14, HORN, MAN</b>

If Any **PB1-PB5, PB13, PB14, MAN, or HORN** is **Green**:  
(Default setting) Functions tied to each Green button will NOT automatically deactivate whenever the Park-Kill function is activated.

If Any **PB** is **Red**: Functions tied to each Red button (**PB1-PB5, PB13, PB14**) WILL automatically deactivate whenever the Park-Kill function is activated.

**MAN** is **Red**: Function tied to **SS③** output WILL automatically deactivate whenever the Park-Kill function is activated.

**HORN** is **Red**: Function tied to **SS①** and **SS②** outputs WILL automatically deactivate whenever the Park-Kill function is activated.

**WARNING!** Once you have programmed all necessary options, you must flip the Programming Mode DIP switch down to save the changes.

## Reset To Factory Defaults

If at anytime during the programming, you are unsure of what settings you have changed, you can reset the unit back to the factory defaults.

To reset the siren to its factory default settings, perform the following.



Programming Mode DIP:	<b>Up</b>
Slide Switch:	<b>②</b>
Activate this button (RED):	<b>RADIO</b>
And press both of these buttons together:	<b>Manual and Horn</b>

- Hold the Manual and Horn buttons and the five amber traffic director LEDs will sequentially light up from left to right.
- Once all of the LEDs have lit up, the siren will elicit a long beep.
- Release the MAN and HORN buttons and the siren will be reset to the factory defaults.

**WARNING!** Once you have programmed all necessary options, you must flip the Programming Mode DIP switch down to save the changes.

## ***Mounting***

### **Safety Precautions**

For the safety of the installer, vehicle operator, passengers, and the community please observe the following safety precautions. **Failure to follow all safety precautions and instructions may result in property damage, injury or death.**

**!!! WARNING !!!**



- DO NOT mount in airbag deployment area!!!
- Devices should be mounted only in locations listed in SAE standard J1849.
- Controls should be placed within convenient reach of the driver.
- Assure clearances before drilling in vehicle.
- Sound levels produced by attached speakers can cause permanent hearing loss.





- Never operate this unit without adequate hearing protection for you and others in the area. (OSHA 1910.95)



- Be sure you have set all of your options prior to installation.
- The LCS850MG control head may be mounted above the dash, below the dash, or in a rack with the mounting u-bracket provided.
- Choose a mounting location convenient to the operator and away from any air bag deployment areas.
- Inspect behind mounting area for clearance.
- Assure adequate ventilation to prevent overheating.
- Consider wire routing and access to connections, as well as microphone bracket placement.

**Control Head**

The standard control head can be mounted using either an adjustable “U” bracket, or mounted directly to a plate or other flat surface using the flange.

- Verify that you have already set all of the applicable option jumpers on the control head.
- Select a location such as the dash, the overhead console, or a center console.
- Choose a mounting location convenient to the operator and away from any air bag deployment areas.
- Consider wire routing and access to connections when selecting location as well.

U-Bracket Mounting

1. The standard control head comes with two interchangeable “U” brackets. Using one of the two “U” brackets as a template, mark at least two mounting holes.
2. Drill the mounting holes in the vehicle and mount one “U” bracket using installer-supplied hardware.
3. Screw the second “U” bracket to the backside of the control head using the two #8 screws provided.
4. Using the enclosed hardware, attach the two U-Brackets together. (See diagram to right).
5. Adjust the control head and tighten the hardware.

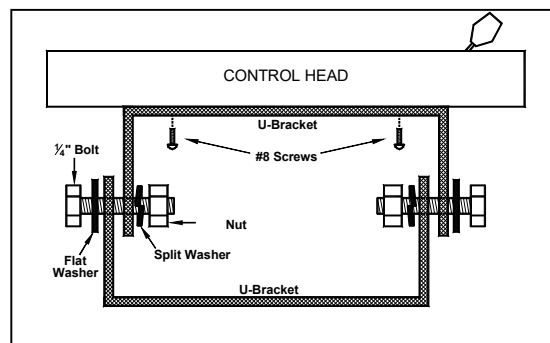

Flange Mounting

- Mark the mounting hole locations and the area to be cut out using the control head installation template provided on the inside of the back cover.
- Carefully drill and cut.
- Connect the communication cable.
- Mount the control using the four #8 screws provided.



### Siren Amplifier and Relay Control Box

- The LCS850MG amplifier should be mounted in a location such as the driver compartment firewall, under the seat, or in the trunk.
- Do not mount the amplifier in the engine compartment, or in an area that would be allowed direct exposure to weather elements.
- Choose a mounting location away from any air bag deployment areas.
- Assure adequate ventilation to prevent overheating.

1. The amplifier unit has four mounting flanges with 1/4-20 clearance holes.
2. Using the amplifier unit as a template, mark the location of the four mounting holes to be drilled. Be sure to check for obstructions behind the mounting hole locations.
3. Drill the four mounting holes and secure the amplifier using appropriate hardware (not supplied).



*Note: Be sure that all wiring harness connections are made prior to connecting the harness to the amplifier unit.*

### Microphone Bracket

A metal clip is provided for mounting the microphone. Choose a location convenient to the operator and away from any air bag deployment areas. Using the mounting clip as a template, mark the two holes to be drilled. Using a 1/8" drill bit, drill the two mounting holes. Install the two #6 screws provided with the bracket.



***Electrical Connections***

The following steps are recommended when installing, to help reduce RFI:

- Make sure that both the control head and amp are securely attached to good chassis ground (i.e. no paint in-between the chassis and the grounding terminal).
- Keep the siren control head and the police radio as far away from one another as is practical.
- Check that the police radio antenna wire makes a right angle from the back of the police radio and runs on one side of the vehicle. The communications cable for the siren should make a right angle out of the back of the control head and exit in the opposite direction from both the police radio antenna wire and the police radio power wires.
- Excess communication cable from the control head to the amp should be tightly bound back near the amplifier box.

***BEFORE installing your siren and running your wires, please review the diagram below showing an example of how the wires should be run.***

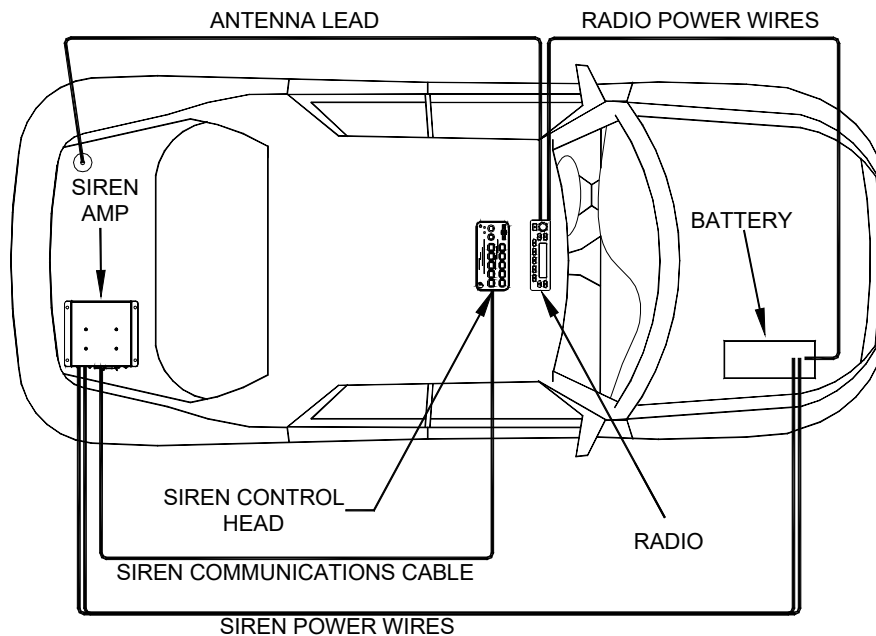

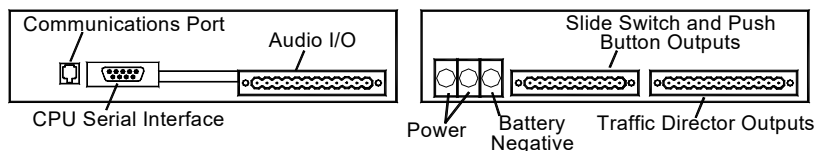

Electrical connections to the unit are made using several terminals and removable connectors located on both the front and back of the unit. The unit is protected by a 20 amp fuse on the input power and each output is protected by a 20 amp fuse. Wiring diagrams on pages 41 and 44 show detail of how to make all of the necessary electrical connections.

### Wire Size and Termination

Please review pages 39-43 to determine the minimum wire size used for each connection. We have enclosed a wiring harness for the Power, Ground, and AUDIO I/O wires that can be used for most applications. Recommended wire colors are listed next to each function. Please also use the following guidelines when wiring your siren:

- Use only high quality crimp connectors.
- Make sure all connections are tight.
- Route the wiring to prevent wear, overheating, and/or interference with air bag deployment.
- Use grommets and sealant when passing through compartment walls.
- Minimize the number of splices to reduce voltage drop.
- Ground connections can be made to substantial chassis components, but preferably directly to the negative of the vehicle battery.
- Install and check all wiring before connection to vehicle battery.

### Power and Ground Wiring Connections

Power (+12VDC) and ground connections are made through several terminal blocks on the back of the siren.

**Ground:** (Black) Make your ground connection using the BLACK 8 AWG wire to the single terminal shown to the right.

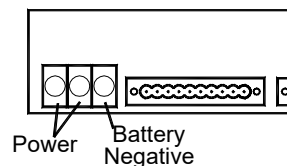

**Power:** (Red) Connect +12VDC to **BOTH** power terminals on the left side of the rear of the unit. Use 8 AWG wires for these connections. The power supply for this unit must be capable of delivering peak currents **up to 150 amps** for adequate short circuit protection and reliable operation (50 amps for the audio functions and up to 100 amps for the additional devices and/or lights you have connected to the outputs). The preferred source is directly at the vehicle battery. Review the chart below for proper Power and Ground wire sizes.

<b>Current Draw(Amps)</b>	<b>10'</b>	<b>20'</b>	<b>25'</b>	<b>&gt;25'</b>
20-30	1 x 8AWG	1 x 8AWG	1 x 8AWG	2 x 6 AWG*
40	1 x 8AWG	1 x 8AWG	2 x 8AWG	2 x 6 AWG*
50-70	1 x 8AWG	2 x 8AWG	2 x 8AWG	2 x 6 AWG*
80-90	1 x 8AWG	2 x 8AWG	2 x 6 AWG*	2 x 6 AWG*
100-140	2 x 8AWG	2 x 6 AWG*	2 x 6 AWG*	2 x 6 AWG*

\* We recommend running the enclosed 8 AWG power wires to a power distribution block located near the siren. Then use two 6 AWG wires for the run to the battery.

**Slide Switch and Push Button Outputs**



The slide switch and push button switch outputs are all made on a 10-terminal connector (P/N P30041-177). Be sure to use a wire size that is appropriate for the load each will be carrying (see pages 39-43). Connect devices that draw a maximum of 20 amps (+12VDC) per output. See the wiring diagram on the next page for the necessary connections.

**P30041-177**



**⚠ MAXIMUM COMBINED OUTPUTS SHOULD NOT EXCEED 100 AMPS TOTAL!!!**  
*Because the voltage in vehicles can fluctuate, we normally do not recommend exceeding 80% of the rated current for each output.*

**⚠** These connectors are designed to handle a **MAXIMUM 12 AWG** wire. If your device has a larger wire (i.e. 8 or 10 AWG), solder a short (4") 12 AWG lead onto the end of the wire so that it can properly fit into the connector.

<u>Current (Amps)</u>	<u>10'</u>	<u>20'</u>	<u>25'</u>
2	18 AWG	18 AWG	18 AWG
4	18 AWG	16 AWG	16 AWG
5.5	18 AWG	16 AWG	14 AWG
8	16 AWG	14 AWG	14 AWG
12	16 AWG	12 AWG	12 AWG
14	14 AWG	12 AWG	10 AWG
18	14 AWG	10 AWG	10 AWG
20	12 AWG	10 AWG	8 AWG

*The chart to the left shows the required wire gauge to be used for each output (1-10) above, based upon the current draw of the light (or device) connected to it and the length of the wire run to the light (or device).*

**Slide Switch:** Each of these terminals should be connected to the +12VDC device you would like controlled by the slide switch in each corresponding position (①, ②, or ③). **Do not exceed 20 amps per output.**

**PB1-PB5, PB13, PB14:** Each of these terminals should be connected to the +12VDC device you would like controlled by the corresponding pushbutton switch. **Do not exceed 20 amps per output.** (PB13 will only be used if you are NOT using it to control your traffic director.)

# Siren Wiring Diagram #1

## Inputs and Light Outputs

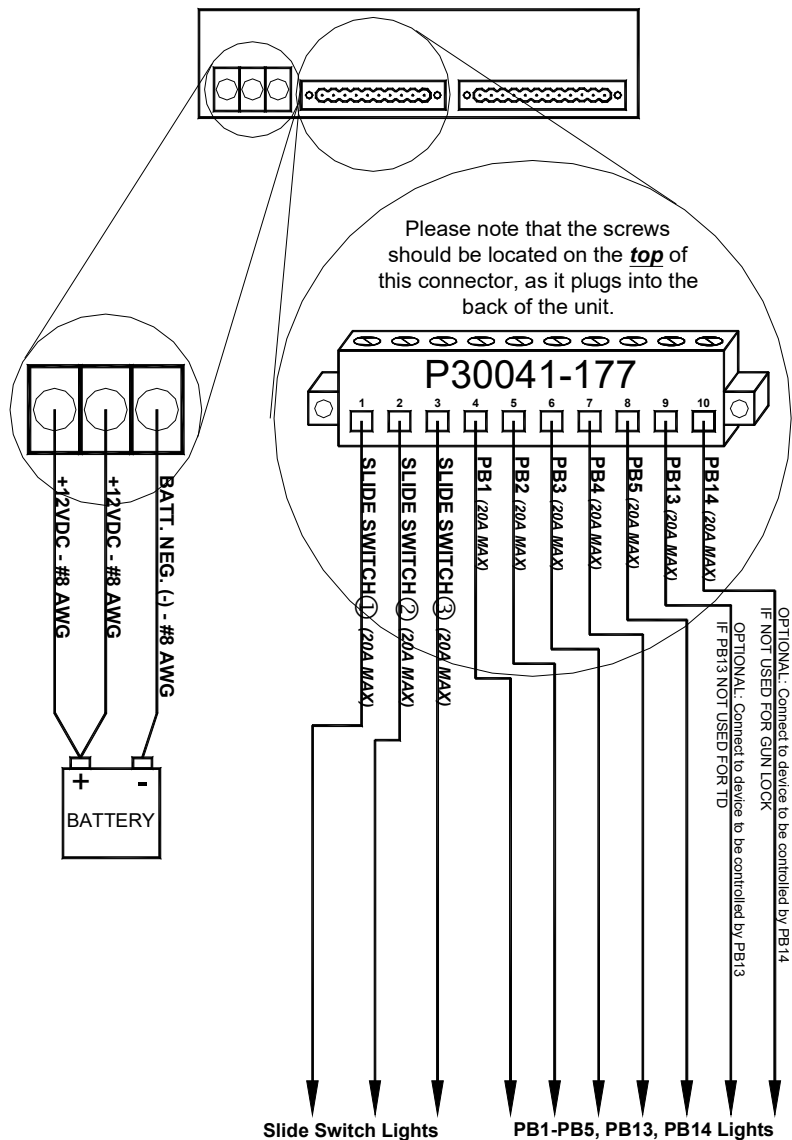

**See the charts on pages 39-40 for proper wire sizes!!**



**Label Insertion**

Once the wire connections have been made to **PB1-PB5**, **PB13**, and **PB14**, labels can be inserted into the switches. The product is shipped with 49 different labels for these push buttons. Select the desired label inserts. Insert the label into each button and tuck it under the lip of the switch.

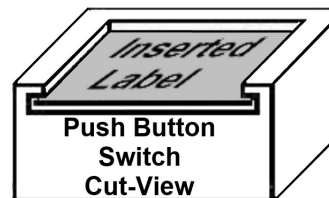

## **Testing**



*Test all siren and light functions after installation to assure proper operation. Test vehicle operation to assure no damage to vehicle.*

**12-Terminal Audio Connector Inputs and Outputs**

(See wiring diagram on page 44)

**P30041-68**

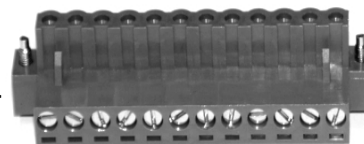

**Terminal 1: Speaker 2 (Negative) - <BROWN>**

Connect to the negative terminal from your second speaker. Use a minimum 14 AWG wire.

**Terminal 2: Speaker 2 (Positive) - <BROWN w/WHITE>**

Connect to the positive terminal from your second speaker. Use a minimum 14 AWG wire.

**Terminal 3: Park/Kill - <GRAY>**

Used for the Park/Kill feature that automatically deactivates the siren (such as when the vehicle is placed in Park or a door is opened). Using an 18 AWG wire, connect this terminal to the dome light, a door switch, or other external switch. By default this wire activates the Park/Kill feature when it receives +12VDC. Optionally, this input can be set to activate the Park/Kill feature when it is grounded (see page 9 of the Installer Selectable Options).

**Terminal 4: Remote Enable - <YELLOW>**

Use an 18 AWG wire to connect this terminal to +12VDC through a switched power supply (possibly ignition). This will turn the siren and light controls off when the ignition is off. Be sure to use minimum size #18 AWG wire. **NOTE: It is NOT recommended that you connect this to constant +12VDC. This wire must have +12VDC applied to it for the lights and siren to work.**

**Terminal 5 & 6: Radio 1 & Radio 2 - <BLUE>**

Used for radio repeat. Connect one terminal to one output and the other terminal to the other output from the two-way radio (speaker or output connector). This unit has been designed such that polarity is not important. Use #18 AWG wire.

**Terminal 7: Auxiliary (Horn Ring Transfer In) - <GREEN>**

Used for remote Manual (or Air Horn) control. Using an 18 AWG wire, connect to the horn ring circuit or some other remote switch. Typically the Horn wire is disconnected from the Horn and connected to this wire. By default this wire activates the Auxiliary feature when it receives +12VDC. Optionally, this input can be set to activate the AUX feature when it is grounded (see page 9 of the Installer Selectable Options).

**Terminal 8: Horn Ring Transfer Out - <GREEN w/YELLOW>**

If you are using the Auxiliary wire listed above, connect this terminal to the side of your vehicle horn that was disconnected when the horn ring circuit was connected to the AUX wire (see **Auxiliary** above). This allows for normal functioning of your vehicle horn when the siren is off. Normal installation of this unit has the vehicle's horn switch disconnected from the horn and routed to the Auxiliary terminal (see the Wiring Diagram on page 44). Use 18 AWG wire.

**Terminal 9: Gun Lock (Optional Backlight Dim) - <GREEN w/WHITE>**

By default, this input is designed to enable the Gun Lock button when +12VDC is applied to it. If you desire, it can instead be used to dim the backlighting when +12VDC is applied to it (see page 33 of the Optional Settings section).

**Terminal 10: Speaker 1 (Negative) - <BROWN>**

Connect to the negative terminal from your first speaker. Use a minimum 14 AWG wire.

**Terminal 11: Speaker 1 (Positive) - <BROWN w/WHITE>**

Connect to the positive terminal from your first speaker. Use a minimum 14 AWG wire.

**Terminal 12: Backlight Dim (Optional Gun Lock) - <ORANGE>**

By default, this input is designed to dim the backlighting for night driving when Ground is applied to it. If you desire, it can instead be used to release the Gun Lock when Ground is applied to it (see page 33 of the Optional Settings section).

**Siren Wiring Diagram #2**  
(Audio I/O Connector)

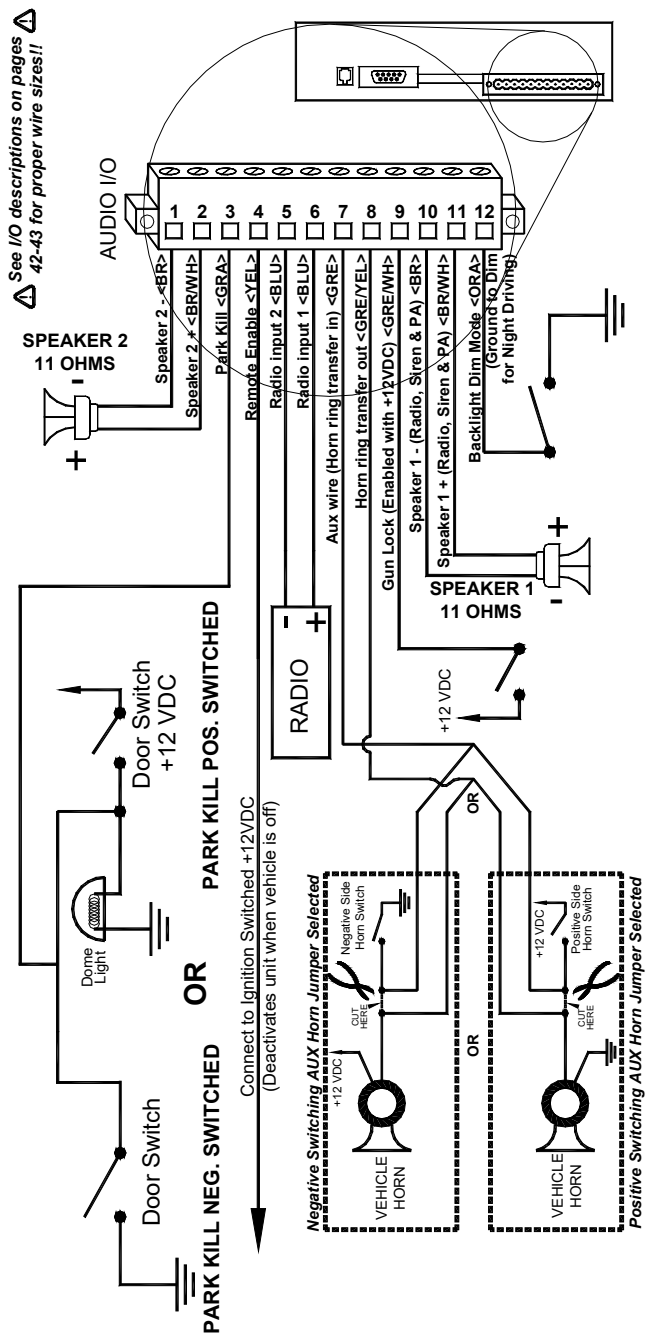

**LCS850MG-XF12 Microphone Harness**

The LCS850MG-XF12 comes with an extension harness for the microphone. Make your connections as indicated below.

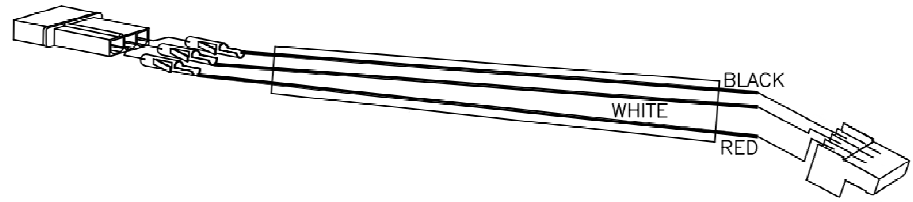

## Operation

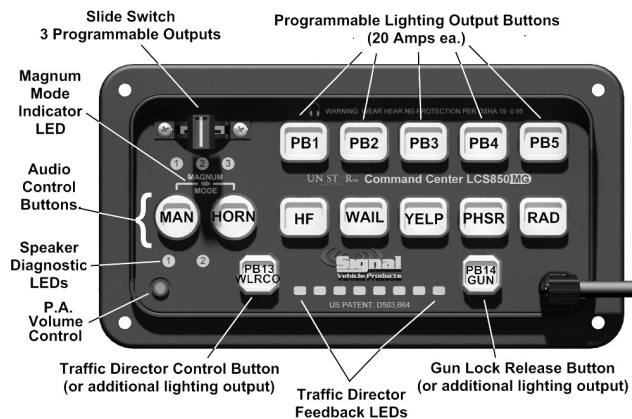

### General

This unit is designed for easy operation under the stress associated with high-speed pursuit. Most siren functions and/or light controls are accessible with one simple motion without repetitive activation of switches or automatic timed switching that can interfere with desired operation.

### Slide Switch

The slide switch is designed for quick pursuit mode operation. The far left position (OFF) will not activate any outputs.

- Position 1:** Activates the first set of lights (connected to Slide Switch Output 1).
- Position 2:** Activates both the 1st and second set of lights (connected to Slide Switch Outputs 1 and 2).
- Position 3:** Generally used for the **FULL PURSUIT MODE**. It allows for a quick procedure that will activate both the lights and the siren in one motion. When the slide switch is moved to **Position 3**, the following will activate:
  - All three sets of lights (Connected to Slide Switch Outputs 1, 2 and 3 - Each output is protected with a 20A fuse)
  - The siren (Wail mode)
  - The Traffic Director lights will flash in a warn pattern

**NOTE:** The siren and the arrow stick may be disabled in the pursuit mode during installation if desired. (Refer to the *Audio and Visual Pursuit DIP switch settings* section on page 6).

### Push Button Switches (PB1-PB5, PB13, PB14)

Seven push button switches are provided to operate your external lights or devices. Each push button (**PB1-PB5, PB13, PB14**) will control the corresponding item(s) connected to Terminals 4-10 of the 10-terminal connector (see page 40). Each of these seven outputs is protected with a 20A fuse (see page 51).

By default, button **PB13** is designed for use with a **compatible** arrowstick (traffic director) and **P14** is set to be used for a Gun Lock release. Both buttons can be used to control other functions if you will not be connecting a traffic director or Gun Lock.

### Audio Mode Buttons

The five (5) push buttons across the middle of the control head are used to select the various “audio modes”. When these buttons are NOT activated, they are backlit in green for nighttime viewing. When activated, an audible beep is heard, and the backlighting turns red.



**Hands Free (HF):** Also known as Horn Ring Cyclor, allows the user to cycle through Wail, Yelp, Phaser, and Standby (Off) by repeatedly pressing the horn or other switch connected to the AUX input. Operating any other mode resumes normal operation. *Please note: this mode disables the Manual (MAN) push button selection when a Wail, Yelp, or Phaser tone is cycled to.*

**WAIL:** A normal rise-fall tone generally used on highways and areas with low traffic or constant traffic flow.

**YELP:** A rapid warble tone used in light to moderately congested areas.

**Phaser (PHSR):** Ultra-fast warble tone used for maximum attention in highly congested areas.

**RADIO:** Also known as Radio Repeat, this function amplifies the two-way radio through the siren speaker(s). PA is available, but no siren tones are available in this position.

### Radio Volume Control

The *Radio Repeat volume control* will control the rebroadcast volume. It is located inside the amplifier case. Typically it will not need to be changed once it has been set.

Locate the *Radio Repeat volume control* inside the housing towards the right hand side and use a small Phillips head screwdriver to adjust the volume.

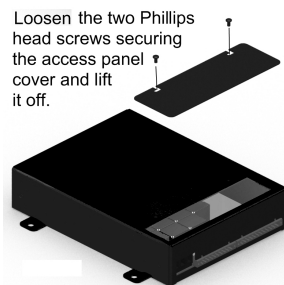

Loosen the two Phillips head screws securing the access panel cover and lift it off.



### PA Volume Control

The *PA volume control (PA)* will control the public address volume. It is located in the lower left hand corner of the front face. Insert a small, flat blade screwdriver into the PA volume adjustment port. Turn counter-clockwise direction to increase the sound level. Typically it will not need to be changed once it has been set.

*(This adjustment does not affect the radio rebroadcast volume. The radio repeat volume control is located inside the amp unit. For details see above.)*

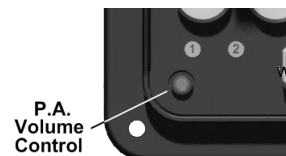

**MAN and HORN Buttons**

There are two (2) other push buttons across the middle of the control head that are used to control additional audio functions, the MAN and HORN buttons.



**Manual (MAN):** In Standby (no Audio Modes activated) or Hands Free Mode, this momentary push button switch provides a manually activated “**Momentary Wind Up**” siren tone while being pressed.

With the Wail, Yelp, or Phaser mode selected, the MAN button provides a generally quicker changing tone (*see table below*). These quicker tones are used to momentarily alert motorists at intersections and very highly congested areas. Pressing the button once changes to the next faster tone. Pressing the manual button again, reverts the siren back to the original tone.

*Note: If your siren is NOT in Magnum Mode, the tone from both speakers will “step up”. If your siren IS in Magnum Mode, only one of the tones (speakers) will “step up”. The other will remain unchanged.*

**Activation of MAN Button**

Siren Mode	Magnum Mode Off		Magnum Mode On			
	No MAN Button Speaker 1 & 2	MAN Button Pressed Speaker 1 & 2	No MAN Button		MAN Button Pressed	
			Speaker 1	Speaker 2	Speaker 1	Speaker 2
<b>WAIL</b>	Wail	Yelp	Wail	Wail	Yelp	Wail
<b>YELP</b>	Yelp	Phaser	Yelp	Yelp	Phaser	Yelp
<b>PHSR</b>	Phaser	Two-Tone	Phaser	Phaser	Two-Tone	Phaser
<b>HF</b> (Hands Free)	No Output	Momentary Wind Up	No Output	No Output	Momentary Wind Up	Momentary Wind Up
<b>Radio</b>	Radio Repeat	No Effect	Radio Repeat	No Effect	Radio Repeat	No Effect
<b>Standby</b> (None)	No Output	Momentary Wind Up	No Output	No Output	Momentary Wind Up	Momentary Wind Up

**Air Horn (HORN):** This momentary push button switch provides a simulated air-horn tone while pressed. This can be used to either replace, or to supplement the normal vehicle horn and is useful at intersections or in high noise areas. This tone will override all other siren tones.

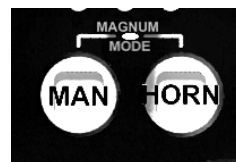

In many modes, the siren's Air Horn can also be activated by pressing the vehicle's horn switch (if you have connected your Horn Ring Transfer to Terminals 7 & 8 of the 12-terminal Audio I/O connector as described on pages 43-44). The chart below summarizes the functionality of the AUX terminal/HRT.

**Activation of AUX Terminal/Horn Ring Transfer**

Siren Mode Selected:	Speaker Output (Both)	Activating the AUX function/HRT Changes the Speaker Output to:
WAIL	Wail	Air Horn
YELP	Yelp	Air Horn
PHSR	Phaser	Air Horn
HF (Hands Free)	No Output	Steps through from Standby to Wail to Yelp to Phaser then repeats.
RADIO	Radio	Radio
Standby (None)	No Output	Air Horn

**Magnum Mode**

The amplifier box in the LCS850MG contains two separate amplifiers that allow the user to operate two separate and distinct tones at the same time. This dual tone (Magnum) feature creates a unique sound that makes it one of the most attention getting amplifiers on the market today. The Magnum sound allows a single vehicle to sound like several vehicles traveling at the same time.

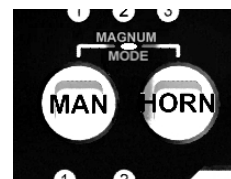

Normally, the siren will automatically be in Magnum Mode when a siren tone is activated. See the **Magnum Mode** DIP switch section on page 7 if you DO NOT want the siren to automatically be in Magnum Mode when a tone is activated.

Magnum Mode can be enabled or disabled at any time during siren operation by pressing both the MAN and the HORN buttons at the same time. If the Magnum Mode LED above the MAN and HORN buttons is lit, the siren is in Magnum Mode. If the LED IS NOT lit, the siren IS NOT in Magnum Mode.

The **Activation of MAN Button** chart on the previous page shows the tones produced by each speaker while in Magnum Mode. If the tones indicated in the chart, while in Magnum Mode, are the same for both speakers, the tones will be staggered and cycle at a slightly different speed than one another, thus mimicking the sound of two vehicles.



### Traffic Director Control Button (PB13)

By default, button **PB13** is designed for use with a **compatible** arrowstick (traffic director). It can be used to control other functions if you will not be connecting a traffic director.



TD CYCLE Button

TD Indicator LEDs

The **TD CYCLE** push button toggles the arrow output through a different pattern with each push. (Warn, Left arrow, Right arrow, Center-Out arrow, and Off). The eight LED's in between the two buttons provide real time user feedback as to the output of the arrow stick.

### Speaker Diagnostics

The LCS850MG is equipped with a pair of diagnostic LEDs that display information about the speakers. Each speaker has a diagnostic LED. These LEDs can be found in the lower left hand corner of the control head, beneath the MAN and HORN buttons. The LEDs will only light up while a tone is trying to be generated.

Speaker Diagnostic LEDs

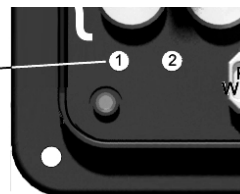

LED ① will apply to the speaker connected to terminals 1 and 2 of the Audio I/O connector (see page 43) and LED ② will apply to the speaker connected to terminals 10 and 11.

Status of the speakers are indicated as follows:

**Steady** - Speaker is connected and operating properly.

**Off** - No speaker is connected, or

- The siren is not activated to output a tone to that speaker, or
- The speaker or wire connection is loose or is electrically open.

**LED 1 Doubleflash** - Park-Kill is activated.

**Both Simultaneous Flashing** - There is an electrical short in one of the speakers or wires to the speakers.

**Both Alternating** - Incorrect voltage (<10 VDC or >16 VDC).

**Both Tripleflash** - Siren Disable/Audio Lockout activated (see page 24).

### Microphone

The attached noise-canceling microphone is used for public address operation and overrides any siren tone when its push-to-talk (button on the side) is pressed.



### Auxiliary Input

During installation an auxiliary input (Terminal 7 of the 12-way Audio I/O connector) may be connected to the vehicle horn ring or other switching device. It provides the same operation as pressing the HORN button or optionally the MAN button. (See the **Installation: Wiring** section on page 43 for details and the **Air Horn** section on the previous page.)

### Park Kill (Cutout)

During installation, the Park Kill input may be connected to a door switch. It will automatically turn off any siren tone when the door is opened. The siren tone will continue to be cut off even when the door is closed. Changing any switch or input will restore normal function. (See the **Installation: Wiring** section on page 43 for details.)

## Cloning

The LCS850MG has been designed to allow for the settings of one unit to be “cloned” or copied to another unit, thus reducing the time that it takes to program multiple units. This feature is extremely useful when setting up fleets of vehicles that will all be using the same (or similar) options.

After setting the options on the first unit, follow the procedure below to copy them onto a second unit (or multiple units).

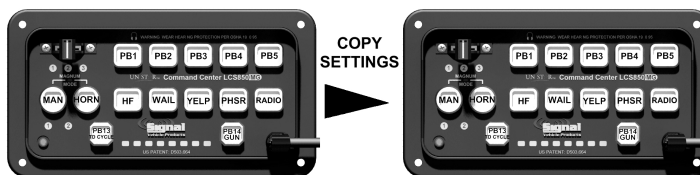

1. After programming the first LCS850MG-CH (control head), make sure it is connected to the amp (this will be the Master Amp), turn it on by applying power to the one of the Power wires and the Remote Enable wire (terminal #4 of the 12-way connector). The Ground wire should also be connected. Ensure slide switch is in the OFF position.
2. Place the unit into Programming Mode by flipping the programming DIP switch up (see page 8 for details about the Programming DIP switch).

3. Move the slide switch to position ③.
4. Press the RADIO button.
5. Press **PB1**. The unit will then begin to beep non stop.

Slide Switch	Audio Mode	Activation Button	Function
①	RADIO	PB1	Write Settings from Master Control Head to Amp
②	RADIO	MAN	Write Settings from Master Amp to Control Head
③	RADIO	HORN	CPU Start

**Please Note:** Do not leave the unit beeping for more than a few seconds as it will eventually corrupt the memory.

6. Flip the programming DIP switch down (out of Programming Mode). This will “save” the settings from the current control head onto the Master Amp.
7. Disconnect the “master” control head.
8. Attach the new control head to the Master Amp that you would like to “clone” from the “master” control head.
9. Turn the new unit on by applying power to the one of the Power wires and the Remote Enable wire (the Ground wire should also be connected), and ensure the slide switch is in the OFF position.
10. Place the new unit into Programming Mode by flipping the programming DIP switch up.
11. Move the slide switch to position ③.
12. Press the RADIO button.
13. Press the **MAN** button. The unit will then begin to beep non stop.
14. Flip the programming DIP switch down (out of Programming Mode). The original “master” control head settings are now saved onto the new control head.
15. To clone additional control heads, repeat steps 8-14. The Master Amp will remember the saved settings even if turned off.

## Service

### Fuses

The outputs on this unit are protected by ten 20 Amp automotive type blade fuses. They are located inside the amp and are accessible through the removable access panel.

Loosen the two Phillips head screws securing the access panel cover and lift it off.

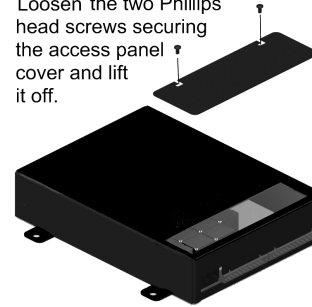

1. To access the fuses, loosen the two Phillips head screws that secure the access cover to the top of the siren, and remove the cover.
2. Once the access cover is removed, you can locate the fuses inside the housing.
3. Please review the diagram below to determine which fuse corresponds to which output.
4. Replace the cover when finished.

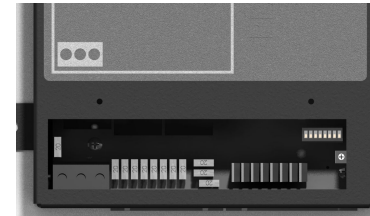
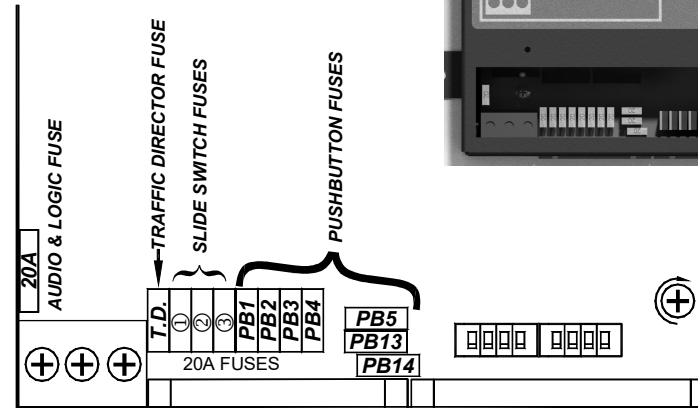

## Parts

Part	Description
P30235-25P	Siren Top Mounting Plate
P30234-25P	Siren Bottom Cover
P30041-68	12-Terminal Connector
P30041-177	10-Terminal Connector
P30069-38	Microphone Bracket with Screws
P30056-14	1/4-20 x 1/2" Hex Locking Bolt
P30028-1	20 Amp Automotive Fuse
P30232-1	Noise Cancelling Microphone
P30208-10	Microphone Strain Relief
P30032-8	TIP36C Power Transistor
P30150-77P	Mounting Bracket
P30052-35	Control Head Mounting Screws
SUSB-850MG	Optional USB Cable w/CD

## Troubleshooting

This unit is designed to provide years of reliable service under even the worst conditions. Many times there may appear to be a problem with the unit when the true problem is in the speaker(s) or improper installation. The following chart shows typical symptoms and possible causes.

Symptom	Possible Cause	Check
No power	No power supplied to +12 terminal block inputs in amplifier. Connector loose Amplifier 20A fuse or 5A fuse blown  Loose connection at power source Remote Enable wire not connected	Does back-lighting come on?  Do you hear a "pop" when turned on? Is power hooked up backwards? Positive ground vehicle? Is an external fuse or circuit breaker used? Are the negative leads connected to a good ground? Check that terminal #4 of the 12-way connector has +12VDC applied to it.
No siren tone - PA works	High voltage protection Low voltage protection Microphone button stuck Park Kill polarity option set wrong Park Kill activated Bad speaker or speaker wiring	The input voltage must be less than 16 volts. The input must be greater than 10V with the siren turned on. Does microphone button release properly? Is the PK DIP switch option properly configured? Does the siren work when Park Kill input is disconnected? Does either speaker diagnostic LED flash? Check for a short. Does neither speaker LED turn on steady? Check for an open.
No siren tone - No sound		
No PA	PA volume not set properly	Have you tried adjusting the PA volume control?
Distorted siren sound	Speaker assembly loose Intermittent Aux. Input connection Low or high vehicle voltage	Is the speaker bell or tip loose? Is the Aux. Input used and wired properly? Input voltage must be 10-16 volts while siren is on.
Intermittent siren tone	High voltage protection Low voltage protection  Microphone button activation Circuit breaker in supply connection Shorted speaker or speaker wire	Is the vehicle voltage regulator working properly? Is the connector tight on the back of the unit? Loose connection on a power lead? The input must be greater than 10V w/ the siren turned on. Is something lying on the microphone? Is a circuit breaker used with at least a 50A rating? Does the speaker have water damage, or is a wire pinched?
Horn function or Manual function stuck on	Siren push button switch stuck Aux. Input improperly connected Aux. Input Polarity Option set wrong	Does the Siren switch return fully when released? Is the AUX Input used and wired properly? Is the AUX jumper option properly configured?
No Radio	Unit not connected to radio Radio volume too low	Is the radio connected properly to the unit? Can you hear the radio in the vehicle? Have you tried turning the Radio volume control?
No or Low Radio	Radio outputs not isolated and polarity hooked up backwards	Are the radio wires connected to the correct polarity from the radio output?
Wrong siren tone	Two-Tone option jumper installed Aux. Input set to wrong function	Is the TT jumper option properly configured? Is the AUX jumper option configured properly?
Phaser not working	Phaser disabled	Is the PD jumper option configured properly?
Lights not working	Overloaded or short circuit	Check fuse. Check wire connections.
Arrowstick not working Erratic arrow stick pattern or 1 <sup>st</sup> or 8 <sup>th</sup> head not working	Fuse blown  Arrow stick option jumpers not set properly Poor connection	Check fuses on arrow stick control box. Check communication cable. Is the 6 head stick option selected? Is 8 head stick option not selected? Is green connector screwed in tight to lock into amp? Are all 12 terminal block connections tight?

***If you have reviewed the chart above and still cannot resolve your issue, reset the unit to the factory defaults as described on page 34 and troubleshoot again.***

If you still cannot resolve your problem, please contact our Technical Service department. When contacting us about a product you have purchased, please have the product's serial number readily available.

**Phone: (585) 226-9025  
CustomerService@star1889.com**

**Fax: (888) 478-2797  
www.starheadlight.com**

### LIMITED WARRANTY

*Signal Vehicle Products warrants this new product to be free from defects in material and workmanship, under normal use and service, for a period of one (1) year from the date of delivery to the first user-purchaser.*

*During this warranty period the obligation of Signal Vehicle Products is limited to repairing or replacing, as Signal Vehicle Products may elect, any part or parts of such product which after examination by Signal Vehicle Products is determined to be defective in material and/or workmanship.*

*This warranty does not cover labor charges for removal or re-installation of the product. Fuses and lamps are not covered under this warranty.*

*This warranty does not extend to any unit that has been subjected to abuse, misuse, improper installation or which has not been adequately maintained, nor to units which have problems related to service or modification at any facility other than the manufacturer.*

*THERE ARE NO OTHER WARRANTIES, EXPRESSED OR IMPLIED, INCLUDING BUT NOT LIMITED TO, ANY IMPLIED WARRANTIES OF MERCHANTABILITY OR FITNESS FOR A PARTICULAR PURPOSE. IN NO EVENT SHALL SIGNAL VEHICLE PRODUCTS BE LIABLE FOR ANY LOSS OF PROFITS OR ANY INDIRECT OR CONSEQUENTIAL DAMAGES ARISING OUT OF ANY SUCH DEFECT IN MATERIALS OR WORKMANSHIP.*

If you have any questions concerning this or any other SVP product, please contact our **Customer Service Department** at (585) 226-9025.

### RETURN

If a product must be returned for any reason, please fill out the form on the back of this page, then call 585-226-9025 and ask for the Repair Department. Once the product is deemed defective by us, an RMA number (Returned Materials Authorization Number) will be issued to you. Please write the RMA number in the appropriate box in the form on the back of this page. Please enclose the form with the returned product(s) and write the RMA# clearly on the package near the mailing label. No returns will be allowed for product returns that are not listed on the RMA.



# Returned Materials Authorization Form

If a problem with this product develops within the warranty period, please contact our Customer Service Department at (585) 226-9025. When contacting us about a product you have purchased, please have the product's serial number readily available. If the product needs to be returned, you will be issued an RMA number (Returned Materials Authorization Number). No returns will be allowed for product returns that are not listed on the RMA. Please fill out the form below and enclose it with the returned product(s).

## Returned Materials Authorization Form

**MODEL: LCS850MG**

<b>Serial No.</b>	<input type="text"/>	<b>RMA Number</b>	<input type="text"/>
<b>Purchase Date</b>	<input type="text" value="/ /"/>	<b>Install Date</b>	<input type="text" value="/ /"/>

**Customer Name:** \_\_\_\_\_

**Company:** \_\_\_\_\_

**Address:** \_\_\_\_\_

**City:** \_\_\_\_\_ **ST:** \_\_\_\_\_ **ZIP:** \_\_\_\_\_

**Phone:** \_\_\_\_\_

**Briefly Describe the Problem:**

\_\_\_\_\_

\_\_\_\_\_

\_\_\_\_\_

\_\_\_\_\_

**Dealer:** \_\_\_\_\_

**Installer:** \_\_\_\_\_

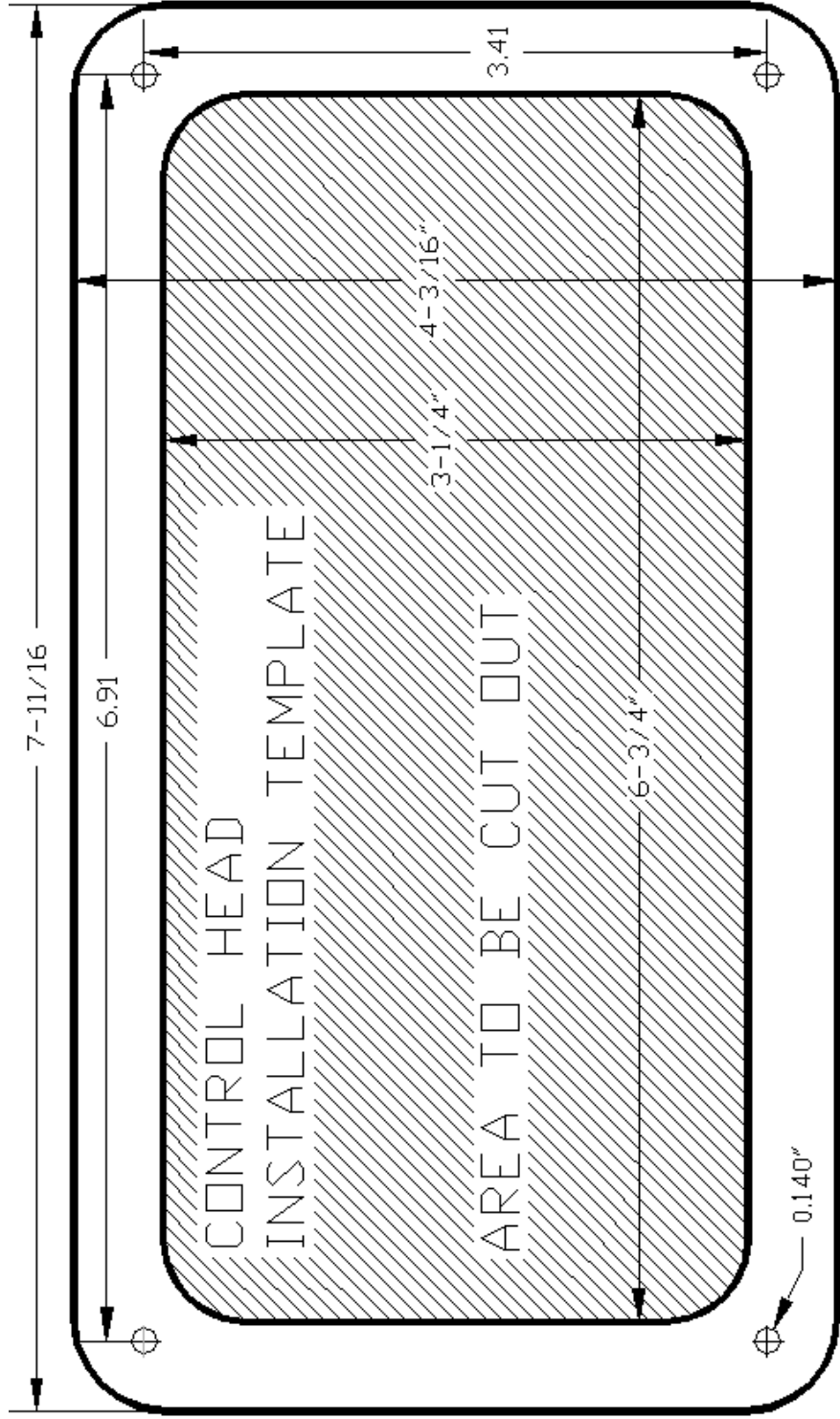



**STAR SIGNAL**  
VEHICLE PRODUCTS



**PROUDLY MADE IN THE USA**  
*An ISO 9001-2000 Certified Company*