

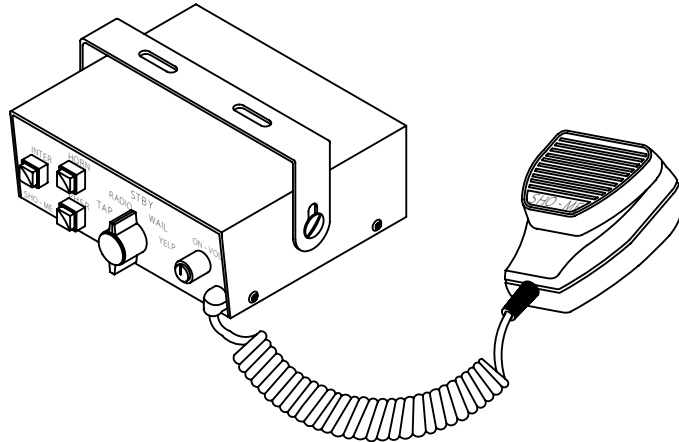

100 WATT FULL FEATURE SIREN

MODEL NO. 30.2100



INTRODUCTION

The 30.2100 siren amplifier powers one 100 watt RMS speaker. The 30.2100 siren contains a rotary switch for mode selection, three push button switches, and an on-off volume switch. This siren is capable of producing sounds commonly known as Wail, Yelp, Phaser, and Airhorn. The 30.2100 also features an intersection mode. **Use only one 100 watt speaker with an 11 ohm impedance.**

INSTALLATION OF SIREN WITH MOUNTING BRACKET

Select a location suitable for installation of the siren. This area must be free from moisture, heat, abuse. Take special care to be certain the siren is not mounted in the deployment area of an airbag! Using the mounting bracket as a template, mark the location of the mounting holes. Drill holes at these locations to assist in starting the mounting screws provided. Mount the bracket, and then mount the siren to the bracket using the supplied screws and washers. When using a horizontal or vertical equipment rack, use of enclosed mounting bracket is not necessary.

WIRING INSTALLATION

BLACK AND BLACK-Connect one conductor of the 16-2 wire to the terminal on the siren marked "SPKR COMMON". Connect the second conductor of the 16-2 wire to the "100 WATT" terminal on the siren. Route 16-2 speaker wire from the siren, to the front of the car to the speaker. Be certain to protect the wire from abrasion and cuts as it passes through the fire wall and other potential problem areas. Cut off any excess wire, and connect to the speaker terminals. When using one speaker, polarity is not a factor.

YELLOW (optional)- Connect to terminal marked Horn Input. Run through fire wall and connect to vehicle horn. (See TAP feature)

BLUE- Attach one wire to the Radio Input(-). Attach second wire to Radio Input(+). Then route one of these to one side of two-way radio speaker and the other to the second side of two-way radio speaker. *Note:* If while testing after installation, a garbling of radio rebroadcast is noticed, reverse the wires at the two-way radio speaker.

BLACK-Connect the black wire to the terminal on the siren marked "GROUND". Connect the other end of the black wire to ground.

RED-Connect the red wire to the terminal on the siren marked "+12 VOLTS". This terminal on the siren connects directly to the on board 20 amp fuse. Connect the other end of the red wire to a positive source. To protect the wiring going to the siren, install an in-line fuse or circuit breaker on the end of the wire as close to the positive source as possible. The current draw of the siren during operation is approximately 8 amps, when supplied by 13.8 volts. The current draw of the siren when power is applied, but no functions are selected is approximately .03 amps.

Note: When in Radio Rebroadcast mode current draw is approximately 1.5 amps.

SIREN FUNCTIONS

ON/OFF SWITCH turns on the siren and controls the level of the P.A. audio produced by keying the microphone and speaking into it. This control does not affect the level of the siren tones, nor does it control the radio rebroadcast audio volume heard on the outside speaker.

TAP-When in this mode, tap the AIR-HORN push-button one time for the WAIL sound. Tap again for the YELP sound. Tap twice quickly at any time and the mode stops.

NOTE: Vehicle horn ring will operate these functions when the yellow wire has been connected between the horn input terminal and the vehicle horn. **OPTION:** The same features above can also be achieved by using the **SHO-ME**® 30.0107 momentary foot switch. For foot switch operation attach yellow wire to black wire of the foot switch (not included) attach red wire of the foot switch to 12 volts positive.

RADIO-The audio from the 2-way radio is rebroadcast over the outside speaker. The AIRHORN, PHASER, INTERSECTION MODE, and P.A. will override the radio rebroadcast. **NOTE:** Volume for the Radio Rebroadcast is pre-set at the factory. Volume can be adjusted by removing the siren cover and locating the potentiometer on the left side of the circuit board. Using a small slotted screwdriver, adjust to desired volume.

STANDBY-If the "INTER" push-button is depressed in this mode, the intersection tones will be produced. If the "HORN" push-button is depressed, the air horn sound will be produced. If the PHSR push-button is depressed, the phaser sound will be produced.

WAIL-This position produces the "WAIL" tone. Depressing the INTER, HORN, or PHSR push-buttons, while in WAIL position, will produce their individual sounds. P. A. will override.

YELP-This produces the "YELP" tone. Depressing the INTER, HORN, or PHSR push-buttons, while in YELP position, will produce their individual sounds. P.A. will override.

P.A.-The P.A. will override all other siren functions, but the preferred mode for operation of the P.A. is STBY.

TROUBLE-SHOOTING

The following list contains some of the most common siren problems and their most probable causes. Most of the problems listed deal with installation or mechanical problems external to the siren electronics. PLEASE review list prior to consulting the factory or returning your unit for service.

1. No output, or backlighting.
 - a. Siren amplifier not connected to power source.
 - b. Internal 20 amp. fuse blown.
 - c. Vehicle supply fuse blown.
 - d. On/Off switch in Off position.
2. Internal 20 amp. fuse blown.
 - a. Reverse polarity at terminal block.
 - b. Short circuit in speaker wiring.
 - c. Defective speaker
 - d. Shorted output transistors.
3. No output from speaker- Siren tones heard inside amplifier chassis.
 - a. Speaker not connected.
 - b. Open circuit in speaker wiring.
 - c. Defective speaker
4. Siren tones sound garbled.
 - a. Low voltage to siren amplifier.
 - b. Defective speaker.
5. Siren volume low.
 - a. High resistance in speaker wiring.
 - b. Low voltage to siren.
6. Siren sounds air horn at all times.
 - a. Remote horn wiring from terminal shorting to positive.
7. P. A. volume too low or no P.A. at all.
 - a. Defective microphone.
 - b. Microphone not completely plugged in (inside).
8. Radio rebroadcast volume low or distorted.
 - a. Potentiometer not adjusted properly (inside).
9. High rate of speaker failure.
 - a. High voltage to siren made for 13.8v.
 - b. SPKR. Mounted improperly for water drainage.

